

The Pictorial Handwriting for Writing The Movements of All Dance Forms

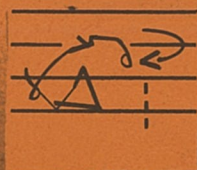

# Dance Writing<sup>T.M.</sup>



FOR  
MODERN AND JAZZ DANCE

Valerie Sutton





The Pictorial Handwriting for Writing The Movements of All Dance Forms

# Dance Writing

T.M.

FOR  
MODERN AND JAZZ DANCE



by  
**Valerie Sutton**



WEST COAST CENTER  
10000 Wilshire Blvd., Suite 100  
Beverly Hills, CA 90210  
(310) 276-1111

THE CENTER FOR MOTION MOVEMENT WRITING  
10000 Wilshire Blvd., Suite 100  
Beverly Hills, CA 90210  
(310) 276-1111

EAST COAST CENTER  
10000 Wilshire Blvd., Suite 100  
Beverly Hills, CA 90210  
(310) 276-1111

# Dance Writing

T.M.

## FOR MODERN AND JAZZ DANCE

COPYRIGHT © (1979) by VALERIE J. SUTTON

ALL RIGHTS RESERVED

ISBN 0-914336-10-4

### NOTICE

This book is copyrighted in the United States of America and in all countries signatory to the Pan American and Universal Copyright Conventions. No part of it may be reproduced in any way unless my written permission has been obtained.

Valerie J. Sutton

Printed and published in the United States of America.



**EAST COAST CENTER**  
P.O. Box 650, Astor Station  
Boston, Massachusetts, 02123-0650  
U.S.A., Telephone: (617) 267-9092

**THE SUTTON MOVEMENT WRITING PRESS**

**THE CENTER FOR SUTTON MOVEMENT WRITING**

(The Movement Shorthand Society, Inc.)  
a non-profit, tax exempt educational corporation



**WEST COAST CENTER**  
P.O. Box 7344, Newport Beach,  
California, 92660-0344, U.S.A.  
Tele: (714) 644-8342 (Voice/TDD)



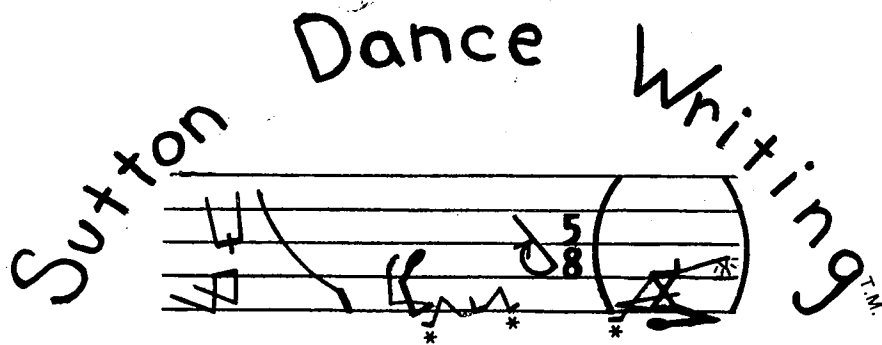

# Quick-Reading

*The Modern/Jazz Dance Key  
Key Two*

READING LESSONS IN SUTTON DANCE WRITING™

BY  
VALERIE SUTTON

DRAWINGS BY

Amy Blake Jayne Gunderson Johan and Jennifer Van Papendorp Lorraine Spada Deborah Talbot

MOVEMENT SHORTHAND SOCIETY PRESS  
P.O. Box 7344, Newport Beach,  
California, 92660, U.S.A.  
Telephone (714) 644-8342



## SUTTON MOVEMENT WRITING

Stanley The Stick Figure, Movement Writing's cartoon character who writes all kinds of movement, from dance to ice skating to sign languages for the deaf, welcomes you to a new world of literature! Now, dance, like music, can be written on paper with a pictorial, stick-figure "dance handwriting".

For centuries movement fields have been hindered by the lack of a written tool. Where music has had the convenience of being able to be read and replayed from generation to generation, movement has been misinterpreted, changed, and oftentimes forgotten as it is handed down by demonstration only. The introduction of video tape as a means of recording movement has benefited the dance field by capturing the feeling of performance and style, but it is also costly and lacks third dimension, requiring dancers to reproduce choreography by stopping and starting the video tape machine for hours. Just as the tape recorder has not replaced the written musical score, video tape cannot answer the same practical need that a handwriting for dance can. The written dance score offers accuracy and efficiency, giving the dancer the chance to create dance, preserve dance and learn dance from the printed page.

Sutton Movement Writing is a new, international movement notation system that writes dance, mime, sports, physical therapy, sign language communication - any motion imaginable. It is visual, practical, versatile and fast. Stick figures dance across the page like a cartoon, creating a film-like impression on paper. Movement can be written at the speed it occurs with the Shorthand section of the system (not in this booklet - contact The Center For Sutton Movement Writing for more information). Sheet Dance™, like sheet music, is now published and available to the general public. It can be read by everyone - by children and adults, by dancer and layman, with only a few hours of training. From the Royal Danish Ballet in Copenhagen, Denmark, to the Boston Conservatory of Music in the United States, dancers from around the world have become well acquainted with Stanley The Stick Figure.

### A Tool For The Dance Teacher

Many dance teachers travel long distances to learn repertoire to teach to students. Now newly-learned repertoire can be recorded on-the-spot by the teacher herself, not with cumbersome terminology that does not capture the details and style, but with visual stick figures that are easy to learn to write. Also, published Sheet Dance™ of many well-known pieces of choreography are available from The Center For Sutton Movement Writing, making it possible to learn dance repertoire at home.

### A Tool To Help Teach Children

Important experiments in teaching Sutton Movement Writing to young children, ages 7-9, show that children who learn to read and write Movement Writing as they learn beginning ballet gain a faster and better knowledge of ballet than those who did not learn notation. This experiment, conducted at the Marblehead School of Ballet in Massachusetts in 1977-1978 is now continuing in other dance studios in the Boston area, including The Edra Toth School of Ballet and The Boston Conservatory of Music's extension classes. The results are written in a report available upon request from The Center For Sutton Movement Writing.



#### A Tool To Help Coach Professionals

Not only can different dance techniques be studied in Sheet Dance™ form in Sutton Movement Writing (for example, the complete Bournonville Schools, the historic ballet training of The Royal Danish Ballet, is now available to the public) but the different roles dancers perform on stage can be analyzed and rehearsed by professionals. Professional dancers can jot down steps learned in training class that are valuable for their technique.

#### A Tool For Choreographers

Musicians have composed music on paper for generations. Now choreographers can compose dances on paper before entering the rehearsal room, saving hours upon hours of rehearsal time. This is possible with Sutton Movement Writing because it is a pictorial system. The stick figures are so visual that if you were to place each individual figure on a separate card and flip the cards, the choreography moves! In this fashion a choreographer can test his choreography on the living room table with this home-animation trick. A choreographer can also become a "published" choreographer when choreographic works are chosen to be published as Sheet Dance™.

#### A Tool For Dance Companies

Until now, dance companies have spent endless hours trying to remember pieces of choreography performed years ago. Oftentimes no one remembers, and new choreography is made, or the piece is thrown-out of the repertoire. Now, with published Sheet Dance™ there will be no question what steps happen when. The score can be read by anyone in the company, since stick figures are universal and can be read with little or no training. The manuscripts can be read from any viewpoint, from the audience's point of view or from the dancer's point of view - a great asset in rehearsals.

#### A Tool For The Dancer Who Needs Employment

Many dancers must work at other jobs to help pay the bills, while they dance part-time. It is frustrating to work at jobs that are not related to dance just because you need the money. Sutton Movement Writing offers an alternative. New careers in Dance Writing™ instruction and notating are opening. The Center For Sutton Movement Writing trains and certifies dancers as teachers and notators of Dance Writing™. Jobs are opening at The Center and elsewhere for part-time or full-time certified Dance Writing™ specialists. Now dancers can work to make money in a field that is directly related to dance.

#### For More Information

Contact The Center For Sutton Movement Writing (The Movement Shorthand Society, Inc.) a non-profit, tax-exempt, educational corporation, founded in California by Valerie Sutton, the inventor of Sutton Movement Writing. Sutton Movement Writing includes Dance Writing™, Sign Writing®, Mime Writing™ and Sports Writing™. The Dance Writing™ office is located in the dance department of The Boston Conservatory of Music in Boston, Massachusetts. For information on Dance Writing™, write to:

THE CENTER FOR SUTTON MOVEMENT WRITING  
P.O. Box 650, Astor Station  
Boston, Massachusetts, 02123-0650  
Telephone: (617)267-9092

# Dance Writing<sup>T.M.</sup>

For  
Modern And Jazz Dance

## TABLE OF CONTENTS

The Five-Lined Staff.....	p. 1
The Parts of The Body.....	p. 2
The Five-Walled Stage.....	p. 3
The Raked Stage.....	p. 3
Facing The Front Wall.....	p. 4
Facing The Front Corners.....	p. 5
Facing The Side Walls.....	p. 6
Facing The Back Corners.....	p. 7
Facing The Back Wall.....	p. 8
Facing The In-Between Walls.....	pp. 9-12
Darkening of The Limbs.....	pp. 13-15
Levels.....	p. 16
THE PLANES OF THE ROOM.....	pp. 17-52
The Frontal Plane.....	pp. 17-22
The Diagonal Plane.....	pp. 23-28
The Sagittal Plane.....	pp. 29-44
The In-Between Planes.....	pp. 45-52
THE PARTS OF THE BODY.....	pp. 53-104
The Face.....	pp. 53-54
The Neck.....	p. 55
The Shoulders and Hips.....	pp. 56-60
The Hands and Fingers.....	pp. 61-74
The Feet.....	pp. 75-76
The Wrists.....	pp. 77-84
The Ankles.....	pp. 85-88
Limbs in Summary.....	pp. 89-90
The Torso.....	pp. 91-99
The Spine.....	p. 100
The Head.....	pp. 101-104
POSITION SYMBOLS.....	pp. 105-156
The Planes of The Body.....	pp. 108-112
The Center Dot and Spokes.....	pp. 113-116
The In-Out Position Symbol.....	pp. 117-120
The Up-Down Position Symbol.....	pp. 121-124



TABLE OF CONTENTS CONTINUED

The Sagittal Center.....	pp. 125-126
Rules for Position Symbols.....	pp. 127-134
The In-Between Facing and Spokes.....	pp. 135-136
The Two Centers/Two Cylinders.....	pp. 137-144
The Rotation Numbers.....	pp. 145-156
Lying On The Ground.....	pp. 157-160
MOVEMENT SYMBOLS.....	PP. 161-182
Four Kinds of Rotation.....	p. 161
Joint-Circular Rotation.....	p. 162
Circular Motion on Three Planes.....	pp. 163-169
Placement of Symbols.....	p. 170
Spinal Undulation.....	p. 171
Movement Away From The Center Dot.....	pp. 172-179
Weight Shifts.....	pp. 180-182
Dynamics.....	pp. 183-184
Pattern Stages.....	pp. 185-186
Special Information Boxes.....	pp. 187-188
Repeat Signs.....	pp. 189-192
Silent Counts, Mover's Counts, Memos and Measure Numbers.p.	193
Modern & Jazz Dance Dance Reading Lessons.....	pp. 194-203

# THE FIVE-LINED STAFF

TOP LINE



SHOULDER LINE

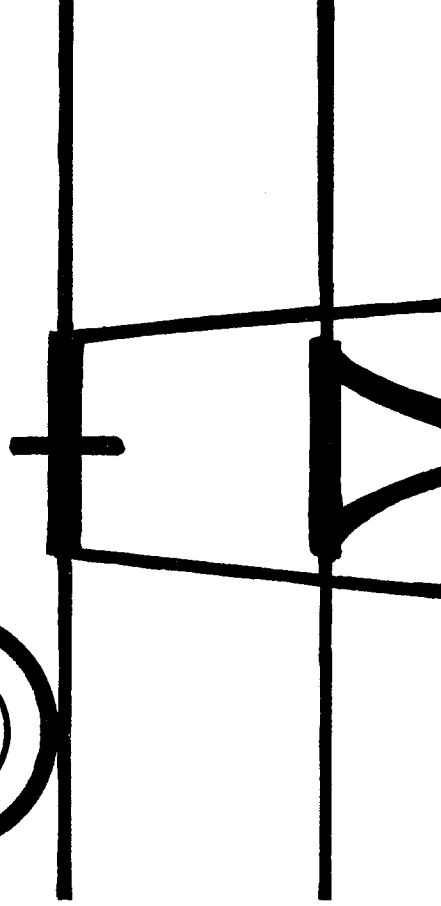

HIP LINE

KNEE LINE

FOOT LINE





# PARTS OF THE BODY

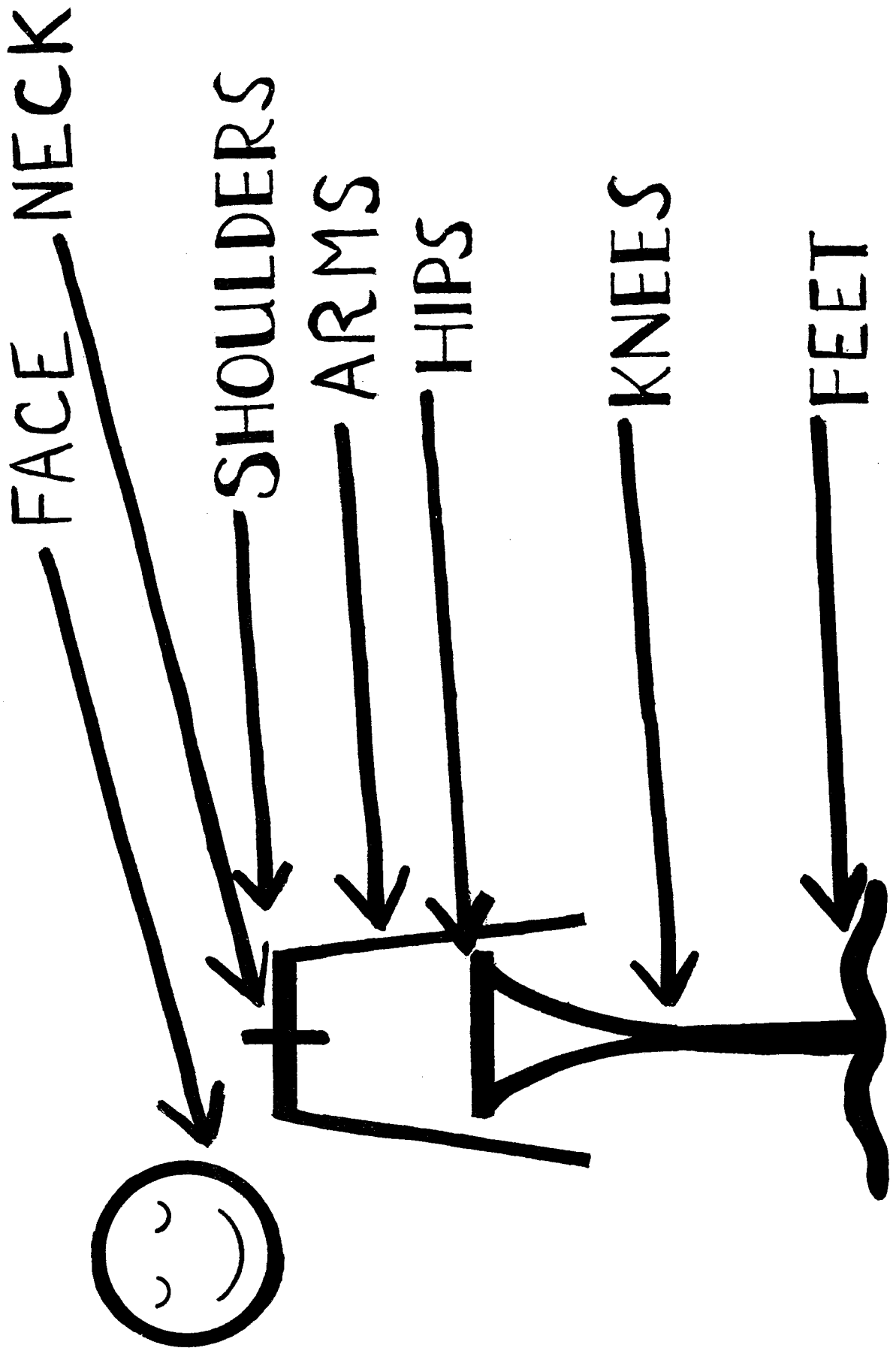

# FIVE-WALLED STAGE

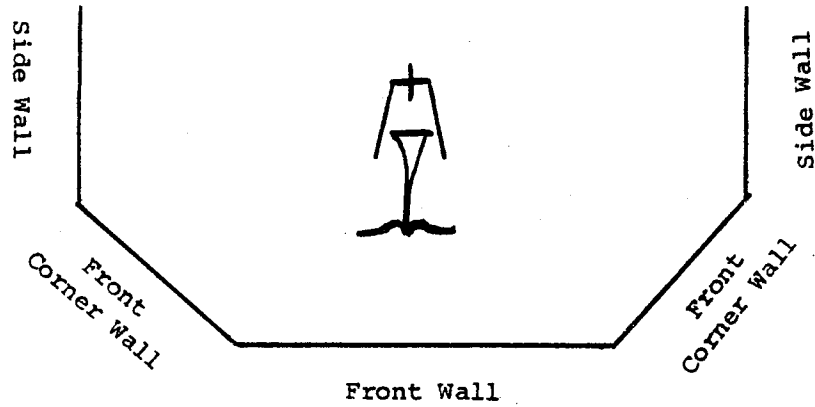

The Reader

The Audience

---

# RAKED STAGE

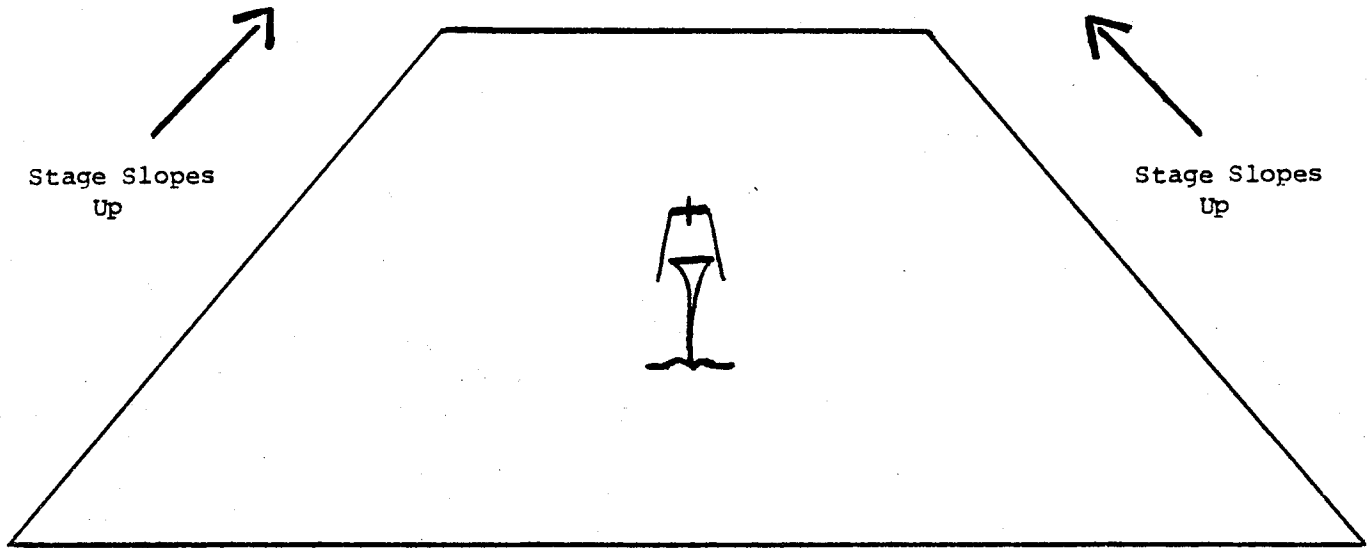

# FACING THE FRONT WALL.....

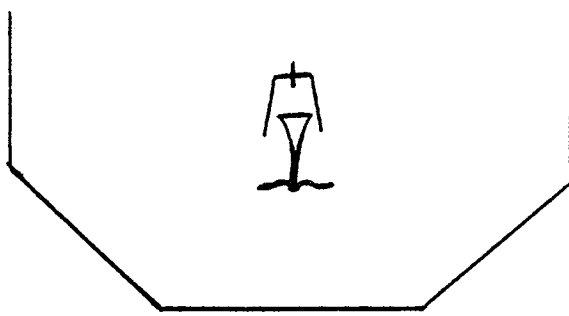

The hips and shoulders are always parallel with the wall the figure faces. When facing the front wall, the hips and shoulders are horizontal.

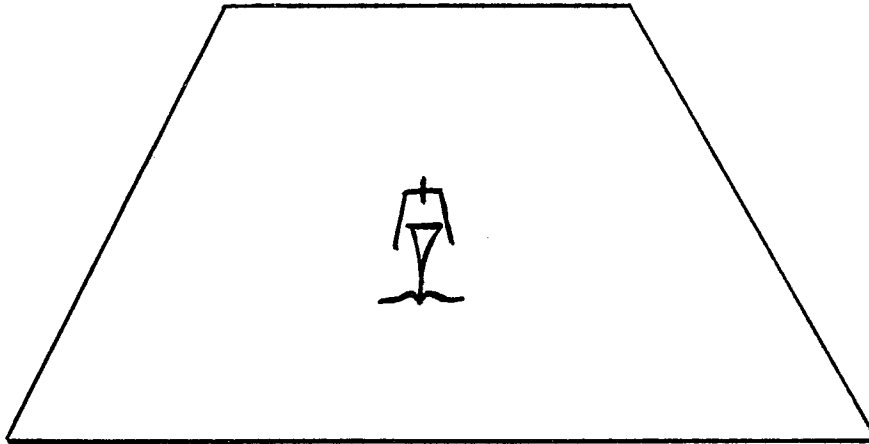

The figure stands on the raked stage. Both hips and shoulders can be clearly seen by the audience.



Facing The Front Wall Written On The Five-Lined Staff

# FACING THE FRONT CORNERS

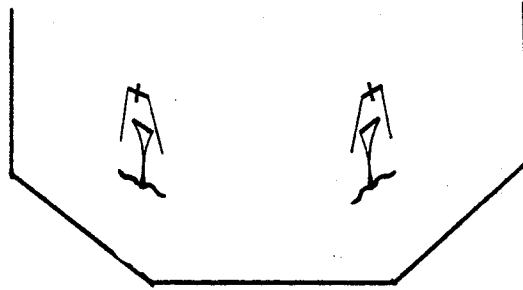

The hips and shoulders are always parallel with the wall the figure faces. When facing the front corner walls, the hips and shoulders slant.

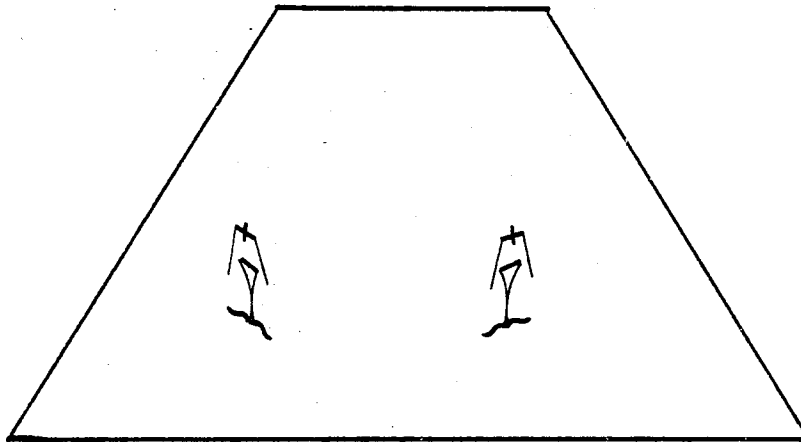

The figure stands on the raked stage. The hip and shoulder closest to the reader (audience) slants down on the raked stage. The foot closest to the reader slants down on the stage. The foot furthest from the reader slants up on the raked stage.



Facing The Front Corner



Facing The Front Corner



# FACING THE SIDE WALLS

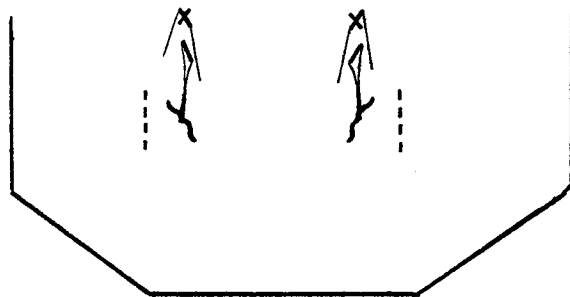

The hips and shoulders are always parallel with the wall the figure faces. When facing the side walls, the hips and shoulders slant at an extreme angle. They are not written totally vertical, but are opened slightly to the audience so that all parts of the body can be seen. A dotted line placed in front of the figure represents the side wall the figure faces. The dotted line states, "This figure faces the side wall squarely, no matter how much the hips and shoulders are opened to the audience to show all parts of the body".

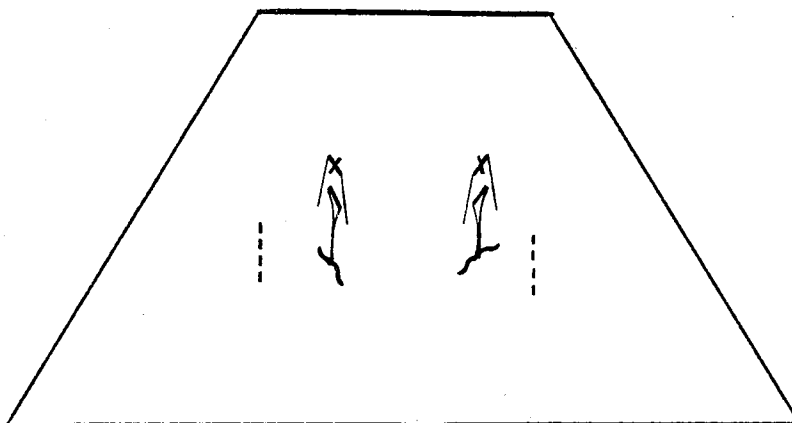

The figure stands on the raked stage. The hip and shoulder closest to the reader (audience) slants down on the raked stage. The foot closest to the reader slants down on the stage. The foot furthest from the reader slants up on the raked stage.

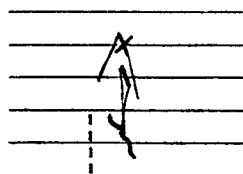

Facing The Side Wall

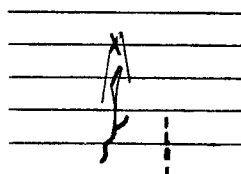

Facing The Side Wall

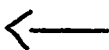



# FACING THE BACK CORNERS

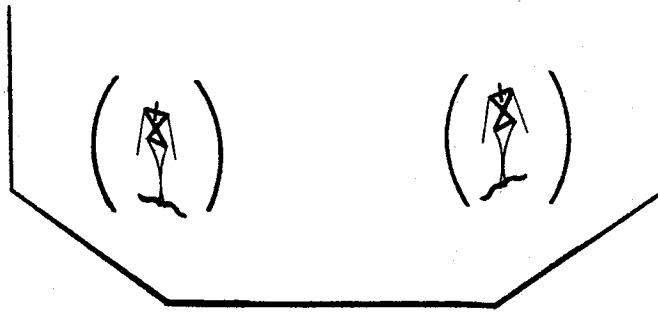

The Five-Walled Stage does not have back corner walls or a back wall. The hips and shoulders of the figure will therefore be relating to the existing five walls behind the figure. The hips and shoulders are now parallel with the front corner wall directly behind the figure. Suspenders are placed on the figure's torso whenever the figure shows its back to the reader (audience). The suspenders ("x") hold the figure's pants up! Parentheses are also written around a group of figures facing the back corners and back wall.

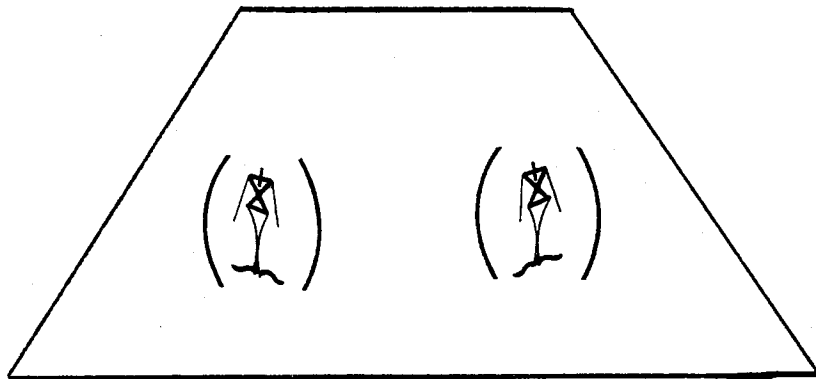

The figure stands on the raked stage. The hip and shoulder closest to the reader (audience) slants down on the raked stage. The foot closest to the reader slants down on the stage. The foot furthest from the reader slants up on the raked stage.

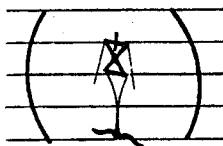

Facing The Back Corner



Facing The Back Corner



# FACING THE BACK WALL...

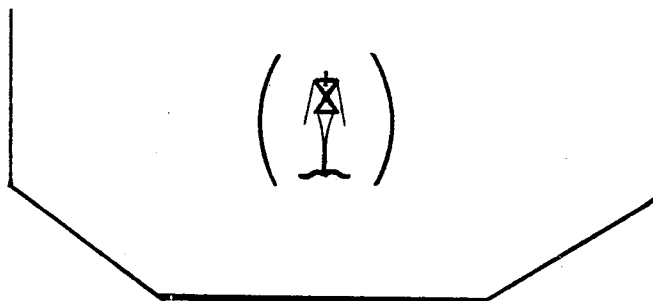

The Five-Walled Stage does not have back corner wall or a back wall. The hips and shoulders of the figure will therefore be relating to the existing five walls behind the figure. The hips and shoulders are now parallel with the front wall directly behind the figure. Suspenders are placed on the figure's torso whenever the figure shows its back to the reader (audience). Parentheses are also written around a group of figures facing the back corners and back wall.

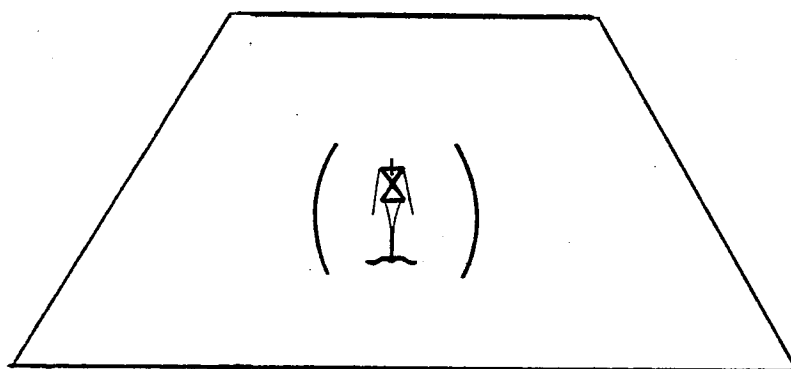

The figure stands on the raked stage. Both hips and shoulders can be clearly seen by the audience.

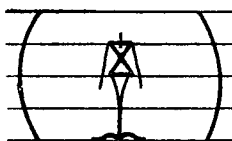

Facing The Back Wall Written On The Five-Lined Staff

# FACING BETWEEN FRONT WALL & FRONT CORNER

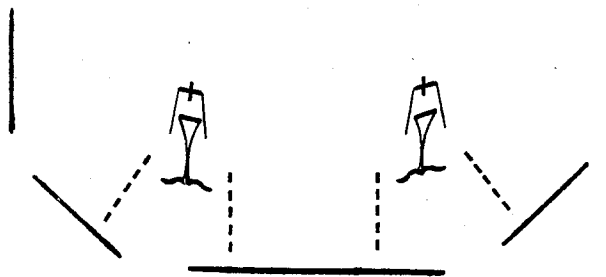

The figure faces between the front wall and the front corner wall of the Five-Walled Stage. Imagine an imaginary wall between the front wall and the front corner wall, shown by blank spaces in the diagram above. The figure's hips and shoulders will be parallel with this imaginary "in-between" wall.

The figure stands between two dotted lines. Each dotted line represents one of the basic eight directions in the room. The dotted lines can also be described as planes that cut the room. The figure stands between these two directions or planes. See pages 17-52 for a more detailed account of the planes cutting the room. The diagram above shows one dotted line going to the front wall and one dotted line going to the corner. The figure stands between the front wall and the corner.

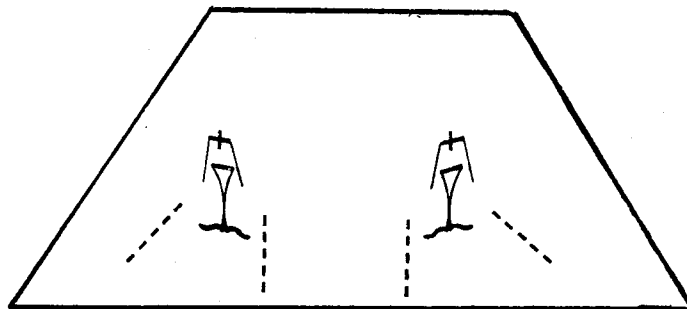

The figure stands on the raked stage. The hip and shoulder closest to the reader is slanted down on the page. The foot closest to the reader slants down. The foot furthest from the reader slants up on the stage.



Facing Between Front Wall And Front Corner Wall

# FACING BETWEEN FRONT CORNER & SIDE WALL

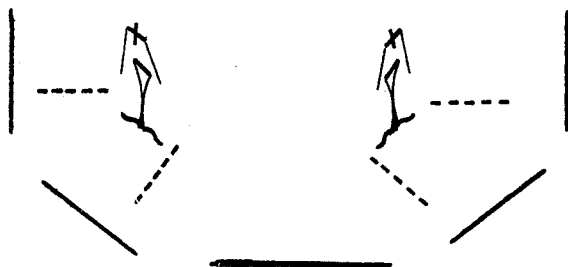

The figure faces between the front corner wall and the side wall of the Five-Walled Stage. The figure's hips and shoulders are parallel with the imaginary "in-between" wall, shown above by the space between the walls.

The figure stands between two dotted lines. The dotted lines represent the planes that cut the room (see page 17-52 ). The diagram above shows one dotted line going to the front corner of the room and one dotted line going to the side wall. The figure is standing between the front corner and the side wall.

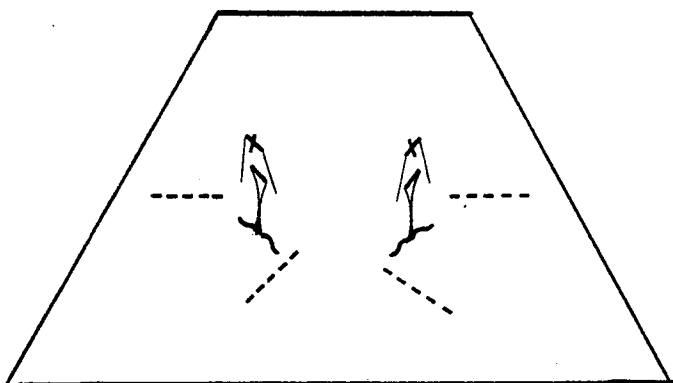

The figure stands on the raked stage. The hip and shoulder closest to the reader is slanted down on the page. The foot closest to the reader slants down. The foot furthest from the reader slants up on the stage.



--- Facing Between Front Corner Wall and Side Wall ---

# FACING BETWEEN SIDE WALL & BACK CORNER

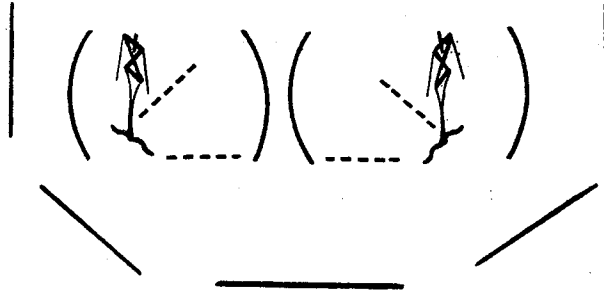

The figure faces between the side wall and the back corner walls of the stage. The back corner walls do not exist on the Five-Walled Stage. The figure's hips and shoulders are therefore parallel with the wall behind the figure, which is, in this case, the imaginary "in-between" wall between the side wall and front corner.

The figure stands between two dotted lines. The dotted lines represent the planes that cut the room (see pages 17-52). The diagram above shows one dotted line going to the side wall of the room and one dotted line going up to the back corner. The figure is standing between the side wall and back corner. Notice the figure has suspenders and parentheses around it. Figures facing between the side wall and back corner follow all rules applied to figures facing the back corner wall.

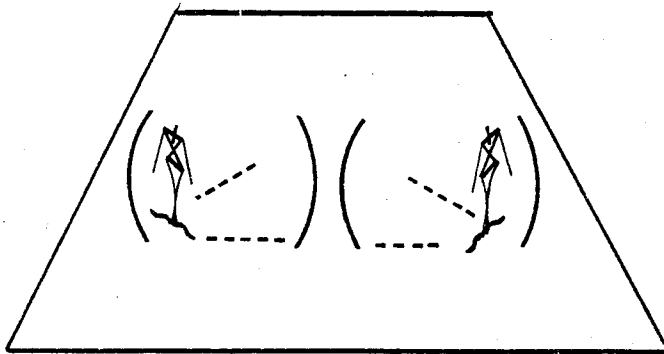

The figure stands on a raked stage. The hip and shoulder closest to the reader is slanted down on the page. The foot closest to the reader slants down. The foot furthest from the reader slants up on the stage.

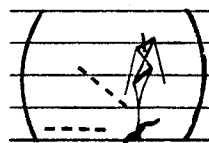
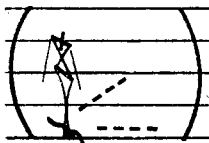

Facing Between Side Wall And Back Corner

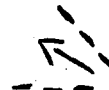
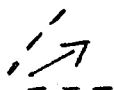



# FACING BETWEEN BACK CORNER & BACK WALL

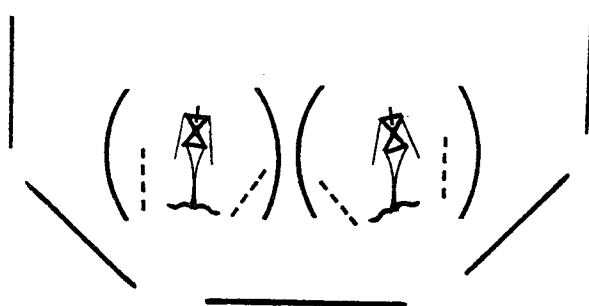

The figure faces between the back corner and back wall of the stage. The back corner walls and the back wall do not exist on the Five-Walled Stage. The figure's hips and shoulders are therefore parallel with the wall behind the figure, which is, in this case, the imaginary "in-between" wall between the front wall and front corner walls.

The figure stands between two dotted lines. The dotted lines represent the planes that cut the room (see pages 17-52). The diagram above shows one dotted line going to the back corner of the room and one dotted line going to the back wall. The figure is standing between the back corner and back wall. Notice the figure has suspenders and parentheses around it. Figures facing between the back corner and back wall follow all rules applied to figures facing the back wall.

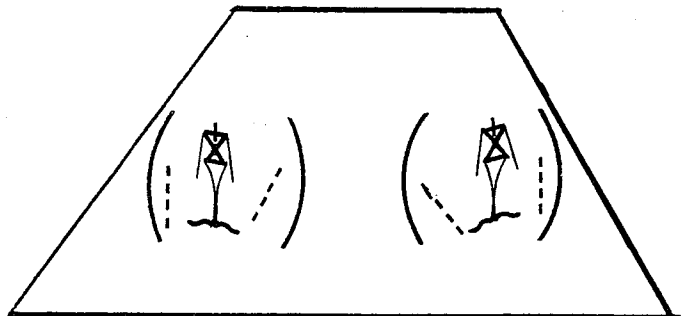

The figure stands on a raked stage. The hip and shoulder closest to the reader is slanted down on the page. The foot closest to the reader slants down. The foot furthest from the reader slants up on the stage.

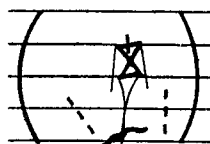
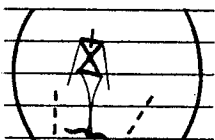

Facing Between Back Corner And Back Wall



# DARKENING OF LIMBS

The limbs of the stick figure are darkened-in at special times. The rules on when to darken a limb are as follows:

The stick figure stands on the five-walled stage. The limbs relate to the five walls of the stage.

The stick figure's hips are parallel with one of the walls of the five-walled stage. The limb of the figure is darkened-in when it is the closest limb to the wall parallel with the stick figure's hips.

When facing the front wall of the five-walled stage, the stick figure's hips are parallel with the front wall. The limb that is closest to the front wall is darkened-in.

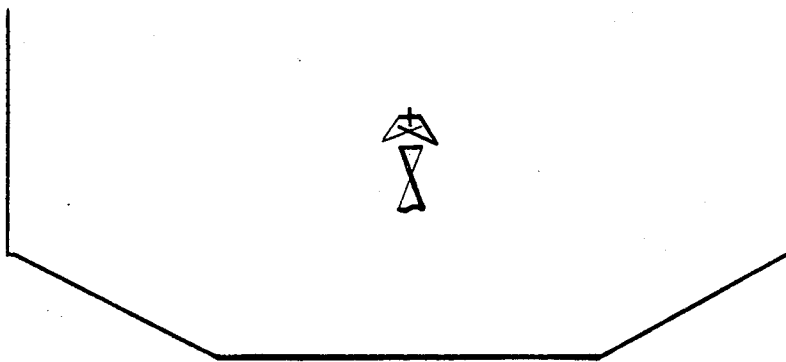

When facing the front corner wall of the five-walled stage, the stick figure's hips are parallel with the front corner wall. The limb that is closest to the front corner wall is darkened-in.

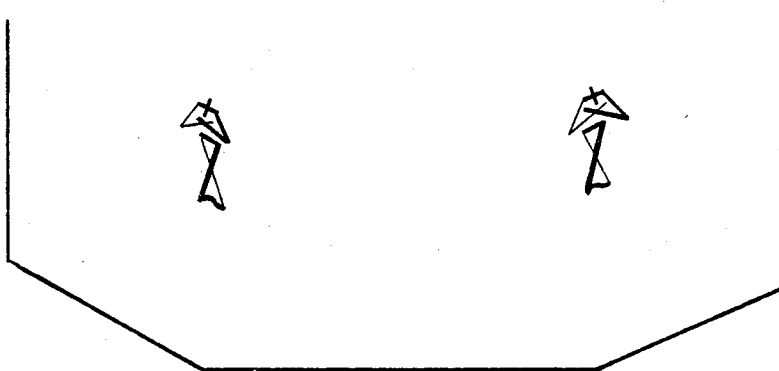

When facing the side wall of the five-walled stage, the stick figure's hips are parallel with the side wall. The limb that is closest to the side wall the figure faces is darkened-in.

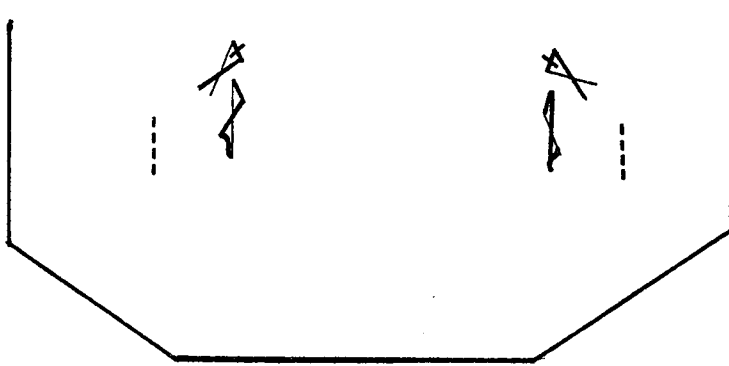

When facing the back corner wall, which does not exist on the five-walled stage, the stick figure's hips are parallel with the front corner wall directly behind the figure. The limb that is closest to the front corner wall behind the figure is darkened-in.

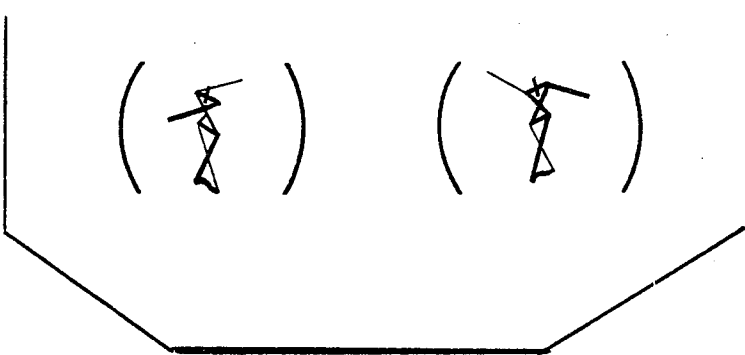

When facing the back wall, which does not exist on the five-walled stage, the stick figure's hips are parallel with the front wall directly behind the figure. The limb that is closest to the front wall behind the figure is darkened-in.

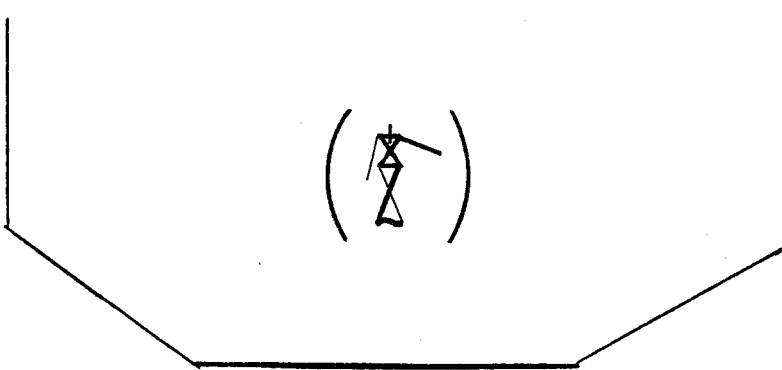

When facing the wall in-between the front wall and the front corner walls of the five-walled stage, an imaginary wall represented by spaces in the diagram below, the stick figure's hips are parallel with the imaginary in-between wall in front of the figure. The limb that is closest to that wall is darkened-in.

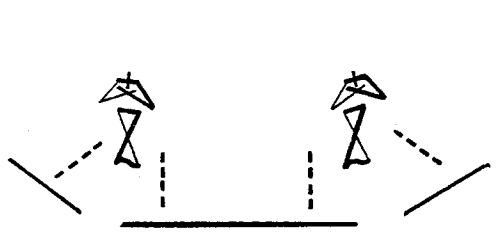

When facing the wall in-between the front corner walls and the side walls of the five-walled stage, the imaginary wall represented by spaces in the diagram below, the stick figure's hips are parallel with the imaginary in-between wall in front of the figure. The limb that is closest to that wall is darkened-in.

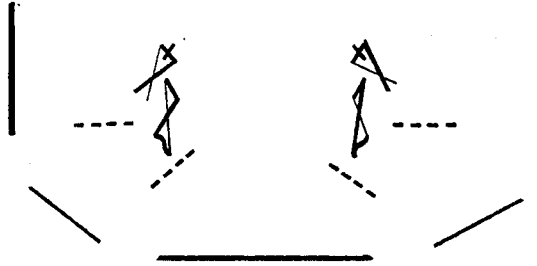

When facing the wall in-between the side walls and the back corner walls, which does not exist on the five-walled stage, the stick figure's hips are parallel with the imaginary in-between wall directly behind the figure. This is the wall between the front corner walls and the side walls of the five-walled stage. The limb that is closest to the wall directly behind the figure is darkened-in.

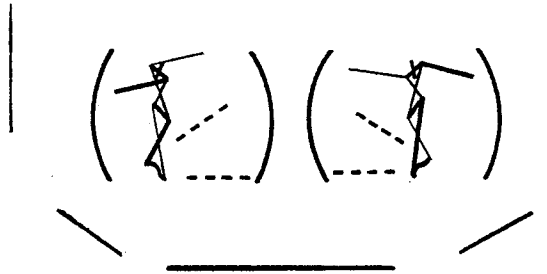

When facing the wall in-between the back corner walls and the back wall, which does not exist on the five-walled stage, the stick figure's hips are parallel with the imaginary in-between wall directly behind the figure. This is the wall between the front wall and the front corner walls of the five-walled stage. The limb that is closest to the wall directly behind the figure is darkened-in.

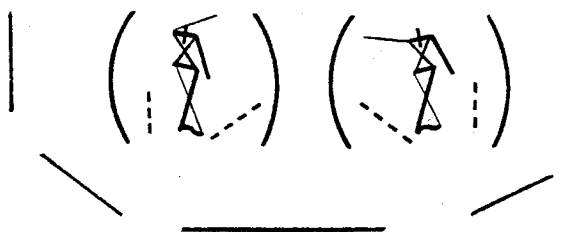

# LEVELS

Normal Level  
Standing Straight

Up 1/8th Space  
Raise Of Heels

Up 1/4th Space  
Raise Of Heels

Up 1/2 Space  
Highest Raise  
Of Heels

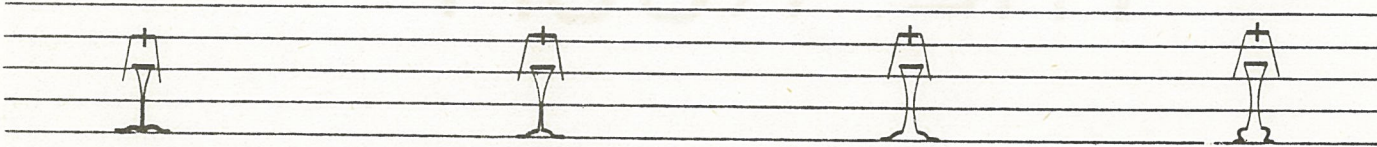

Up 3/4 Space  
On Tip Of Toes

Up 7/8th Space  
Small Jump

Up 1 Whole Space  
Large Jump

Above 1 Whole Space  
Lifts, Acrobatics, Etc.

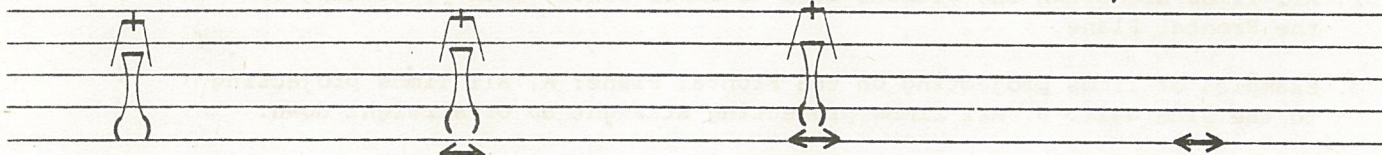

Jumping Arrow  
Under Foot Line

Jumping Arrow  
On Foot Line

Down 1/8th Space  
Bend Of Knees

Down 1/4th Space  
Bend Of Knees

Down 1/2 Space  
Lowest Bend Of  
Knees With Heels  
On The Ground

Down 3/4 Space  
Bend Of Knees  
Lifting Of Heels

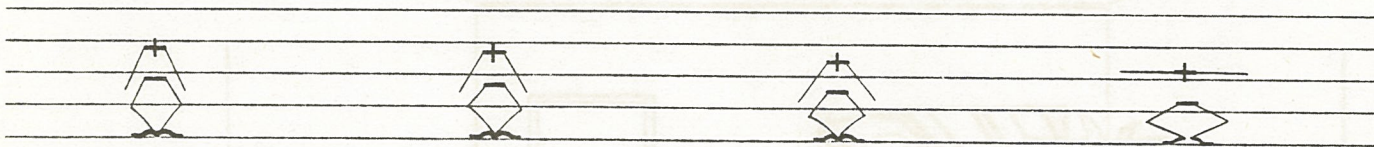

Down 1 Whole Space  
Full Bend Of Knees  
Heels Off Ground

Down 1 and 1/2 Space  
Squatting

Down 2 Whole Spaces  
Sitting Or Lying  
On The Ground

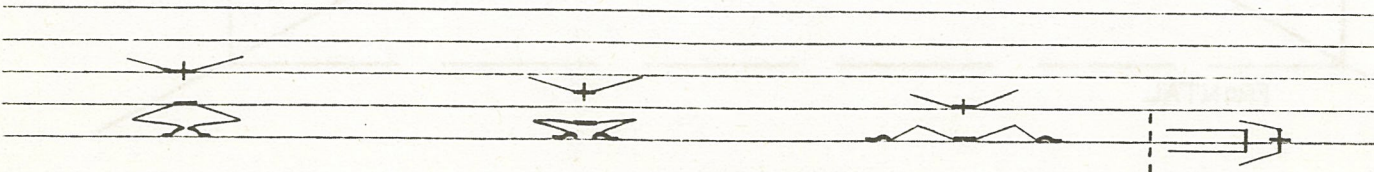



# THE PLANES OF THE ROOM

## THE FRONTAL PLANE

1. The Frontal Plane cuts the room from side wall to side wall, reaching from the ceiling to the floor.
2. All limbs are drawn-in, without dots or small lines, when projecting on the Frontal Plane.
3. Examples of limbs projecting on the Frontal Plane: A. All limbs projecting to the side wall. B. All limbs projecting straight up or straight down.

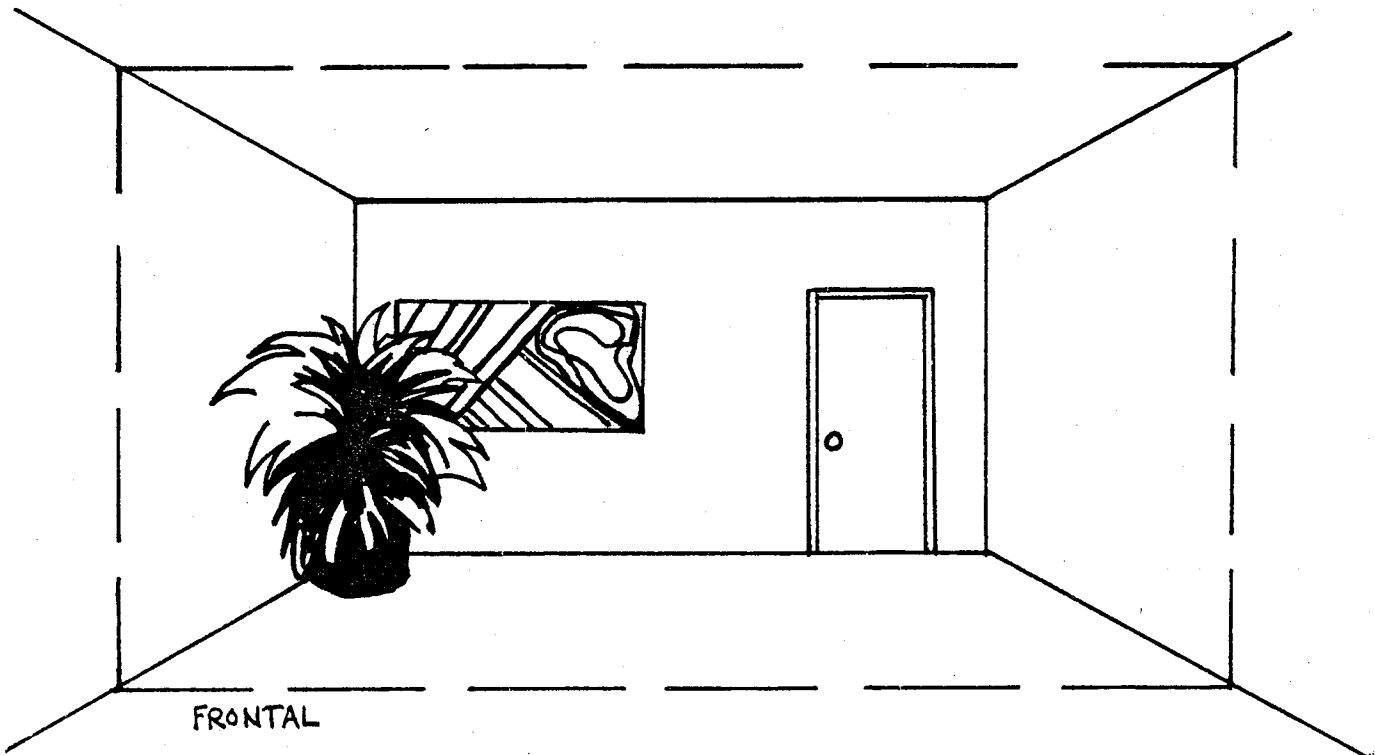

# FEET ON FRONTAL PLANE

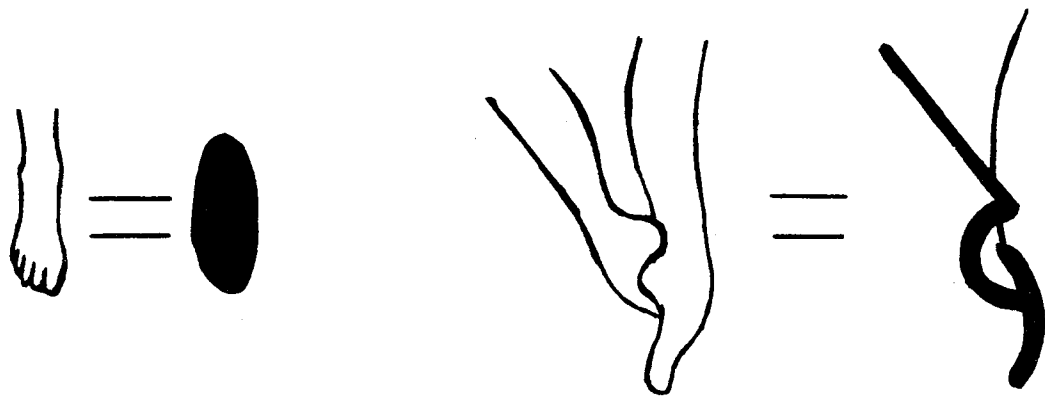
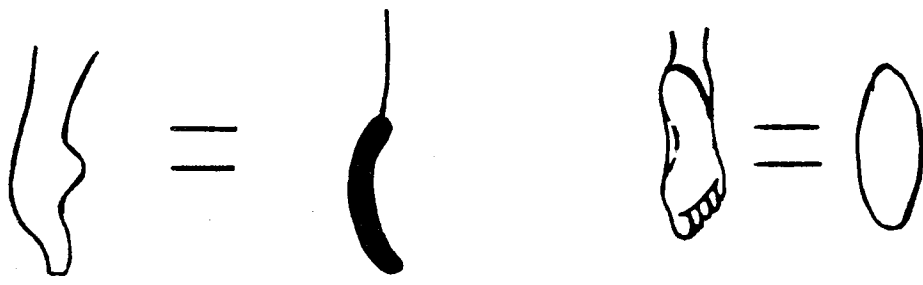

# LEGS ON FRONTAL PLANE

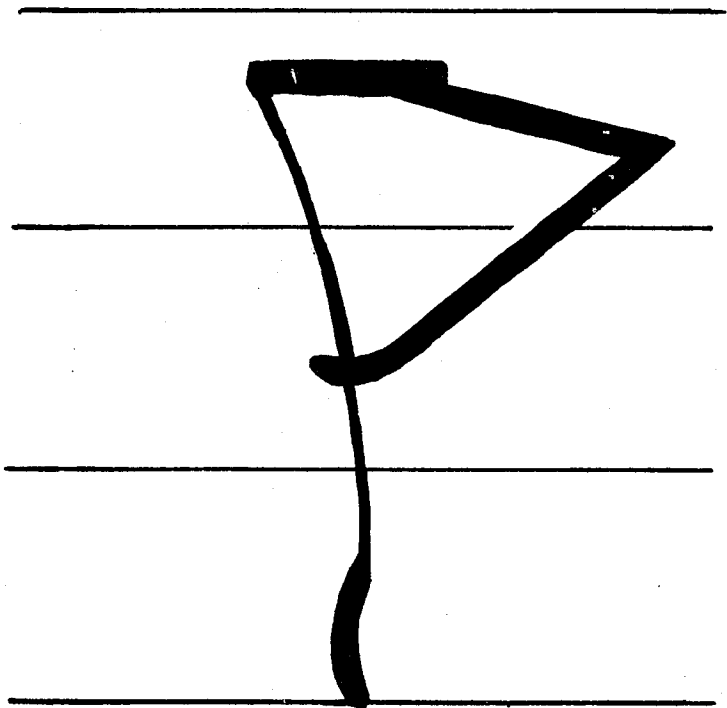
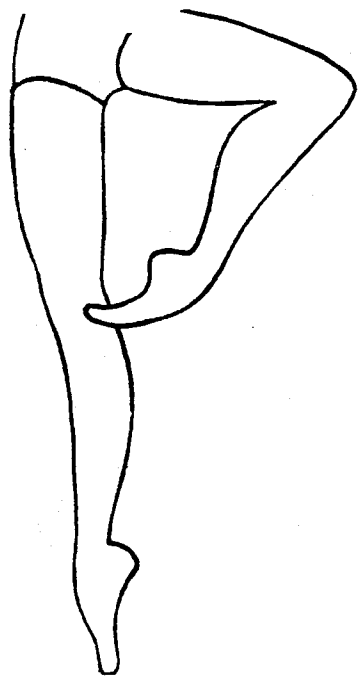
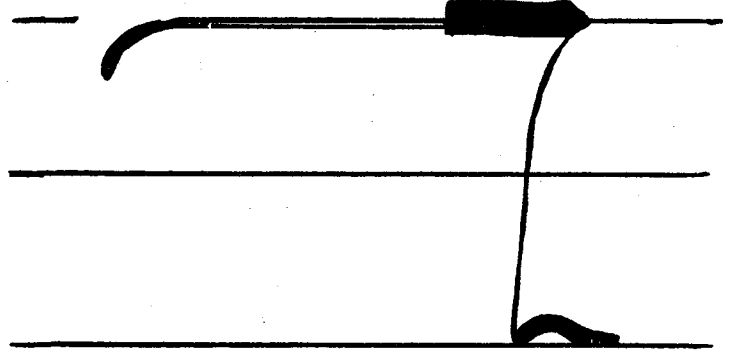
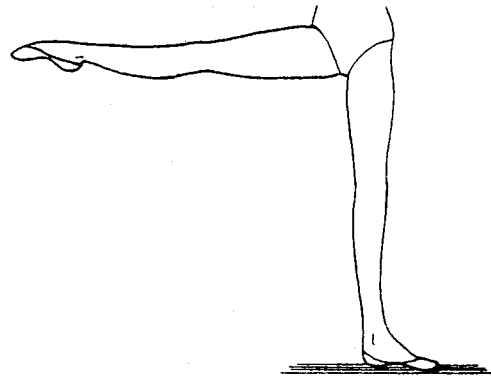
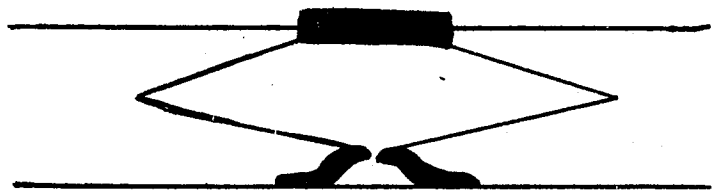
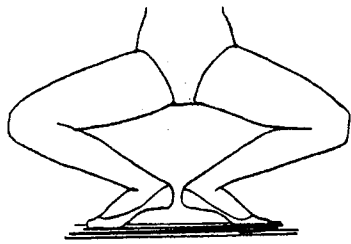

# ARMS ON FRONTAL PLANE

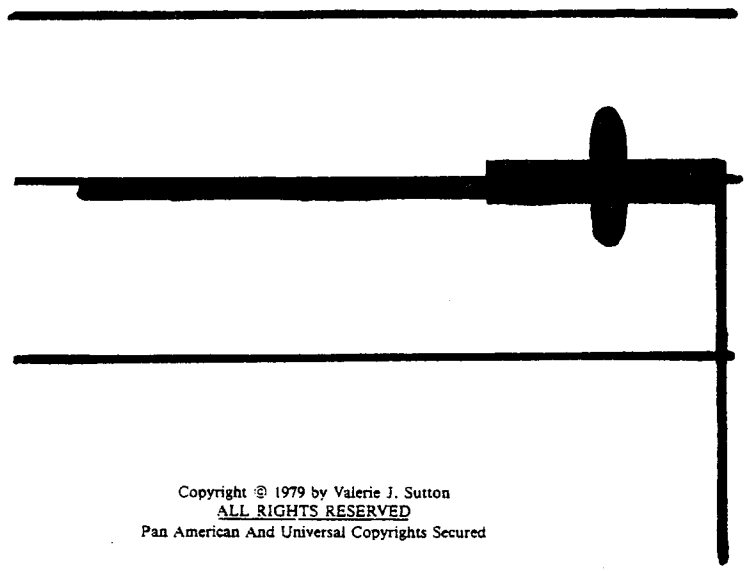
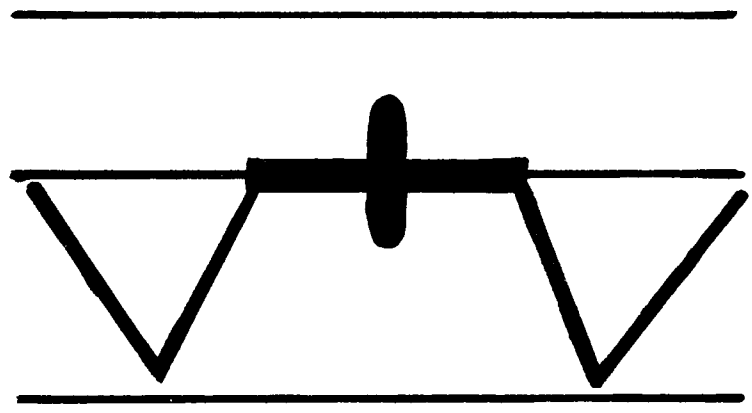
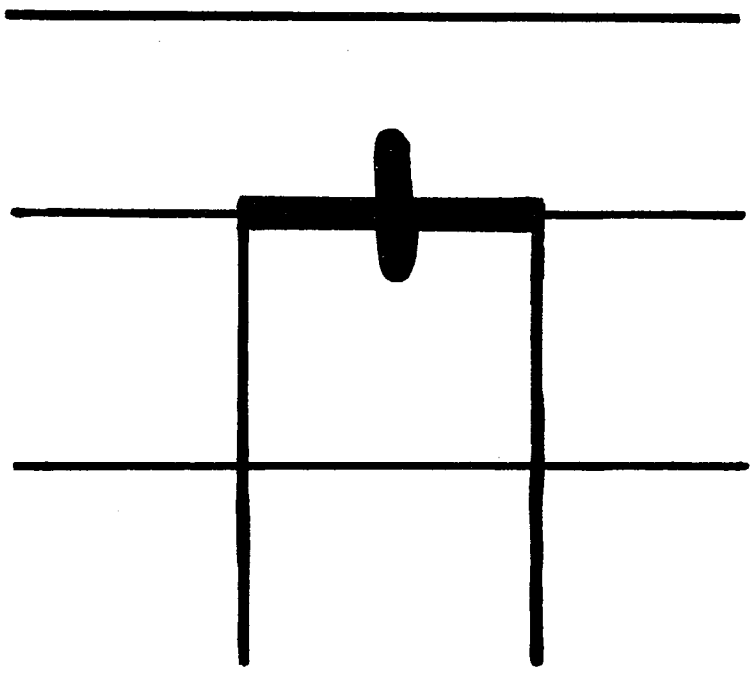
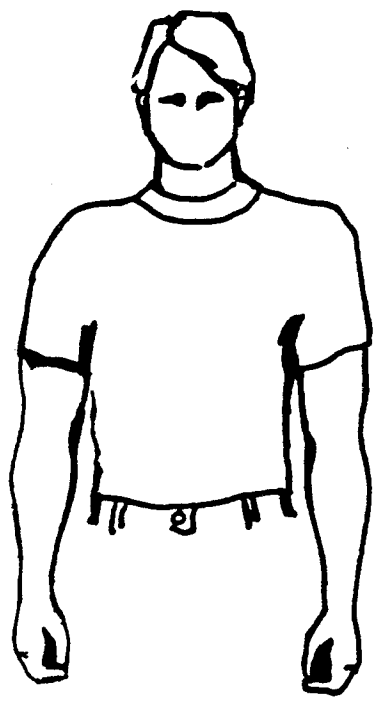

# LIMBS ON FRONTAL PLANE

The following figures have limbs extending on the Frontal Plane of the room.

In rare cases the limbs on the Frontal Plane of the room may possibly appear to be extending on another plane of the room. On pages 105-144 Position Symbols, round symbols written below the five-lined staff, clarify any misunderstandings for the reader. The Position Symbols act as a double check on the stick figure and show the complete third dimension, adding 100% accuracy to all drawings.

Facing  
Front  
Wall

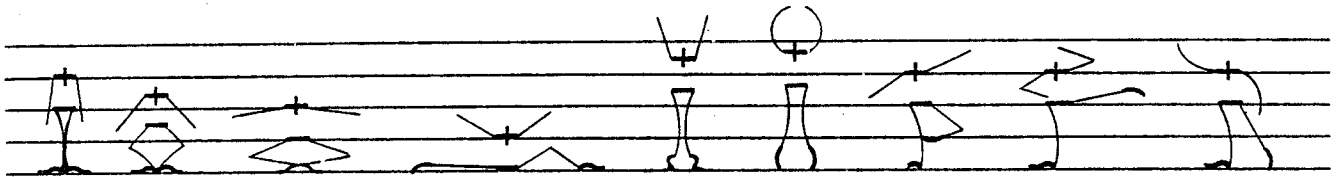

Facing  
Front  
Corner  
Walls



Facing  
Side  
Walls

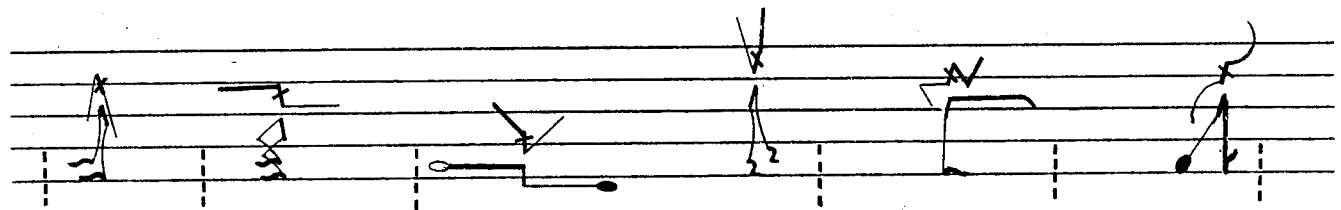

Facing  
Back  
Corner  
Walls

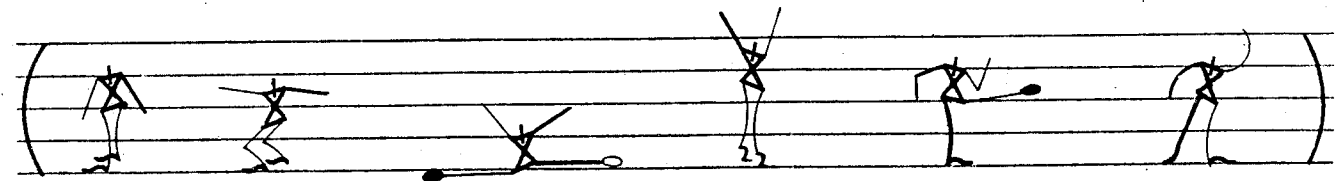



# LIMBS ON FRONTAL PLANE

Facing  
Back  
Wall

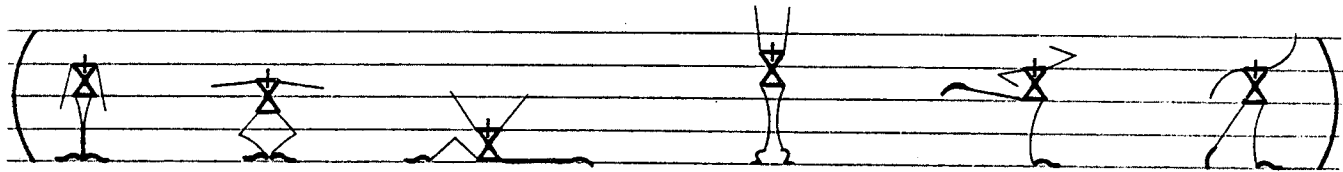

Facing  
Between  
Front  
Wall And  
Front  
Corner  
Walls

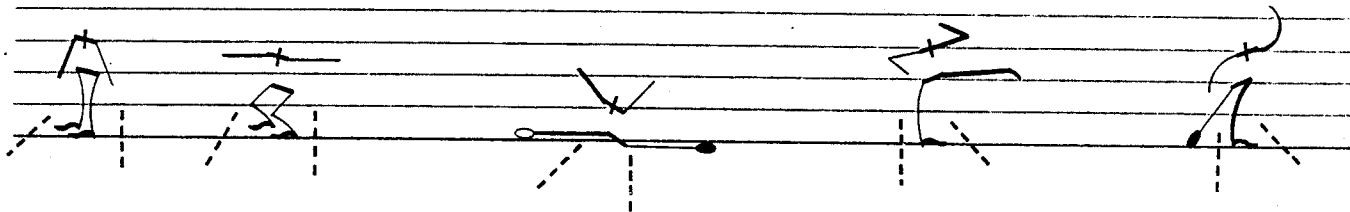

Facing  
Between  
Front  
Corner  
Walls And  
Side  
Walls

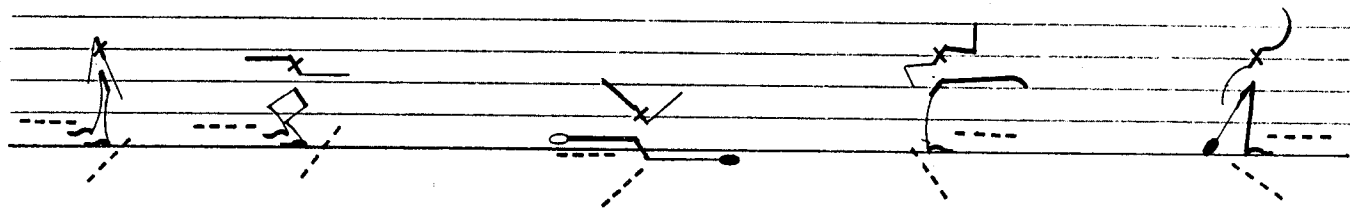

Facing  
Between  
Side  
Walls And  
Back  
Corner  
Walls

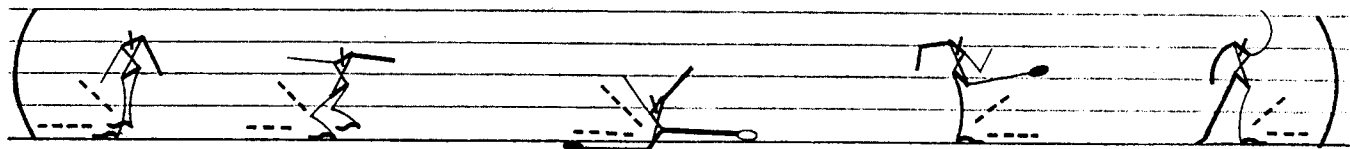

Facing  
Between  
Back  
Corner  
Walls And  
Back  
Wall

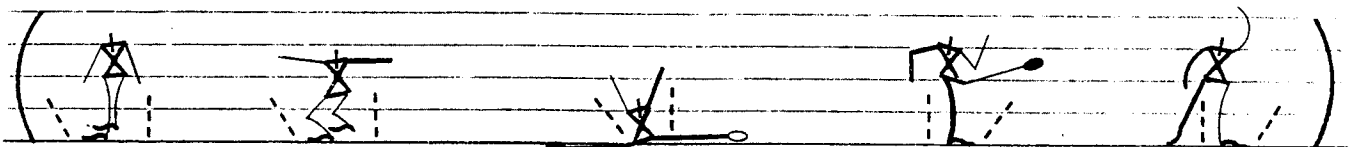

# THE DIAGONAL PLANE

1. The Diagonal Plane cuts the room from front corner to opposite back corner, reaching from the ceiling to the floor.
2. All limbs are drawn-in, without dots or small lines, when projecting on the Diagonal Plane. The limbs are slightly shortened (shorter than limbs projecting on the Frontal Plane).
3. Limbs projecting to the front corner are at times darkened. Limbs projecting to the back corner are not darkened.
4. Examples of limbs projecting on the Diagonal Plane: A. All limbs projecting to the front corner of the room. B. All limbs projecting to the back corner of the room.

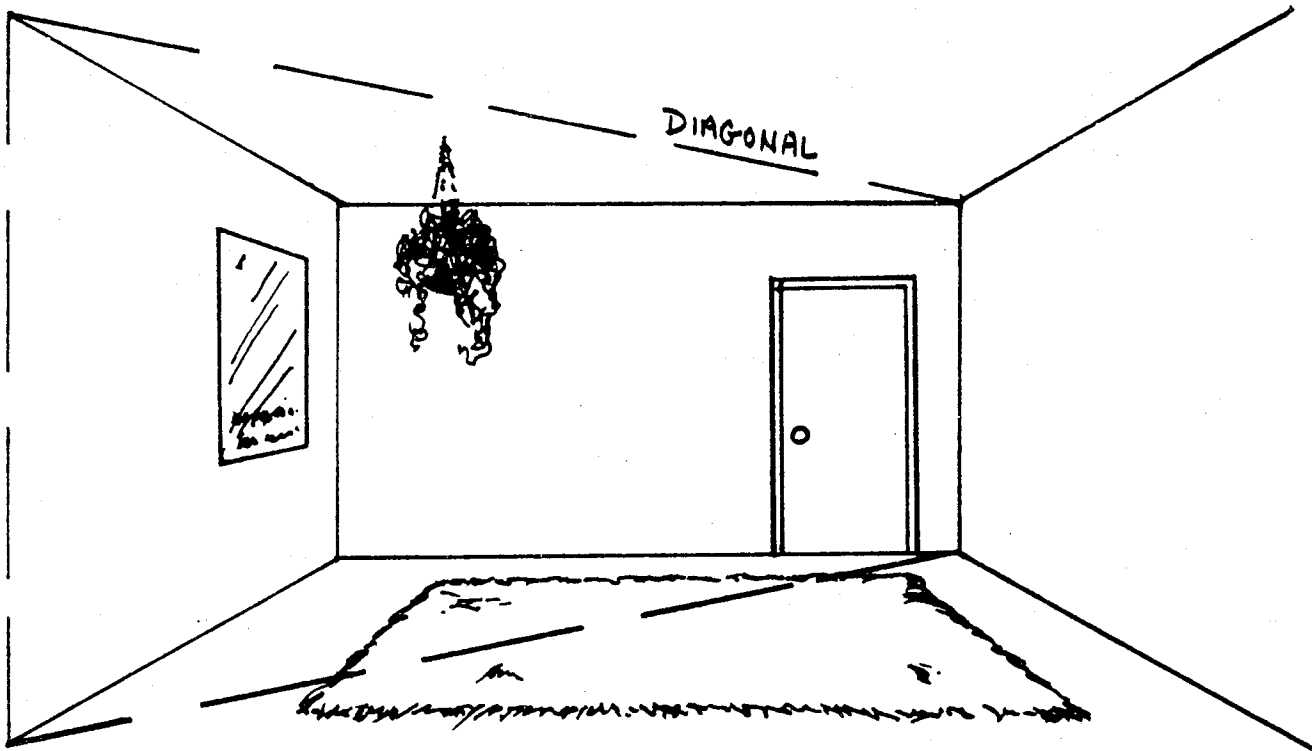

# THE DIAGONAL PLANE

1. The Diagonal Plane cuts the room from front corner to opposite back corner, reaching from the ceiling to the floor.
2. All limbs are drawn-in, without dots or small lines, when projecting on the Diagonal Plane. The limbs are slightly shortened (shorter than limbs projecting on the Frontal Plane).
3. Limbs projecting to the front corner are at times darkened. Limbs projecting to the back corner are not darkened.
4. Examples of limbs projecting on the Diagonal Plane: A. All limbs projecting to the front corner of the room. B. All limbs projecting to the back corner of the room.



# FEET ON DIAGONAL PLANE

*Flat Feet To  
The Front  
Diagonal*

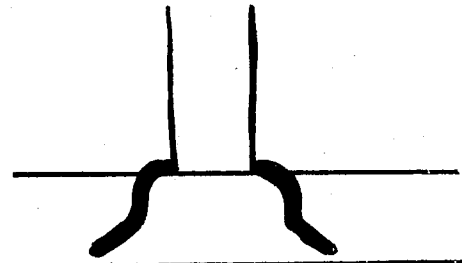

*Slight Raising  
Of Heels, Toes  
To Front Diagonal*

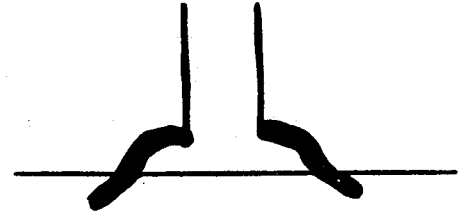

*Highest Raising  
Of Heels, Toes  
To Front Diagonal*

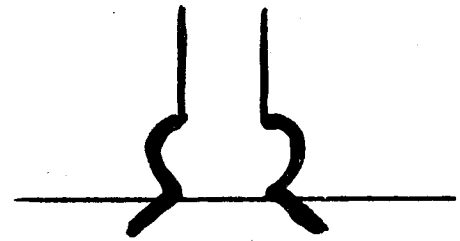

*Flat Feet To  
The Back  
Diagonal*

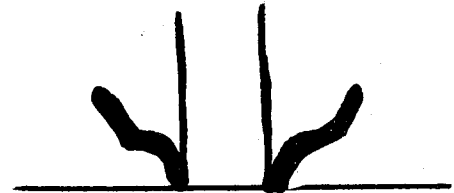

*Slight Raising  
Of Heels, Toes  
To Back Diagonal*

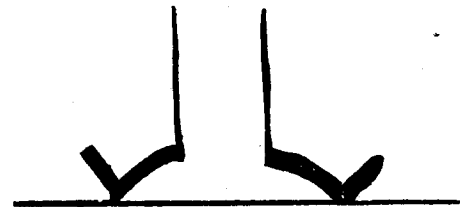
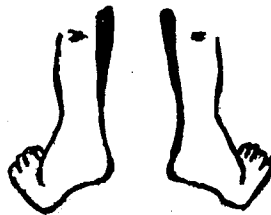

*Highest Raising  
Of Heels, Toes  
To Back Diagonal*

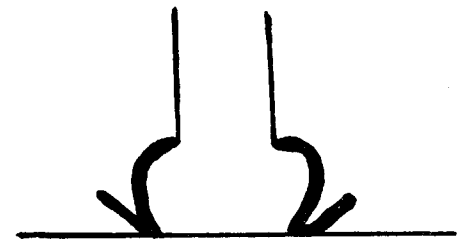
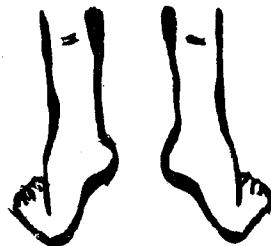

# LEGS ON DIAGONAL PLANE

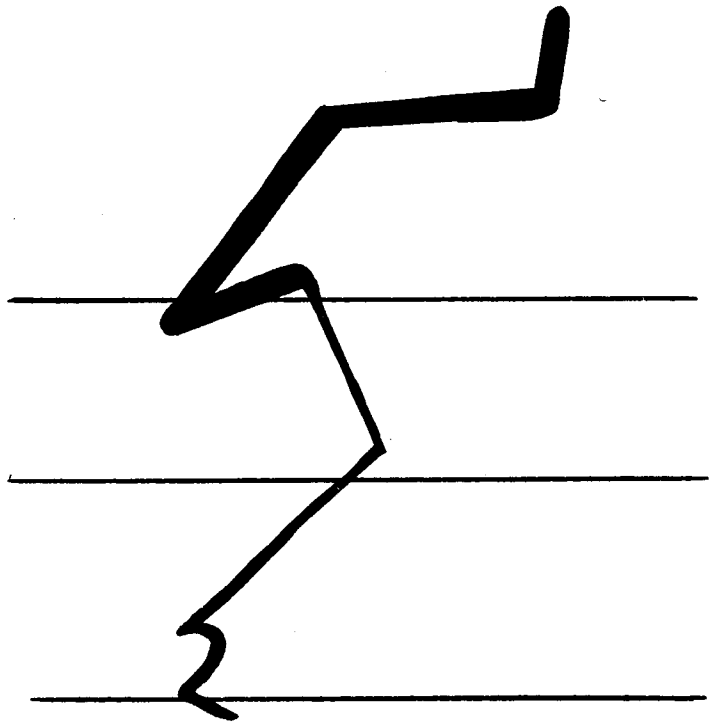
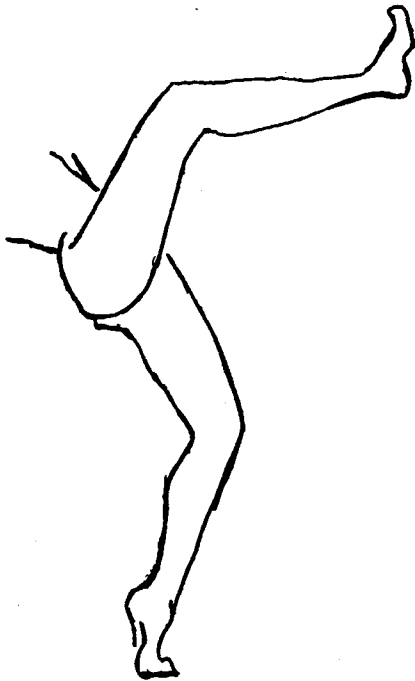
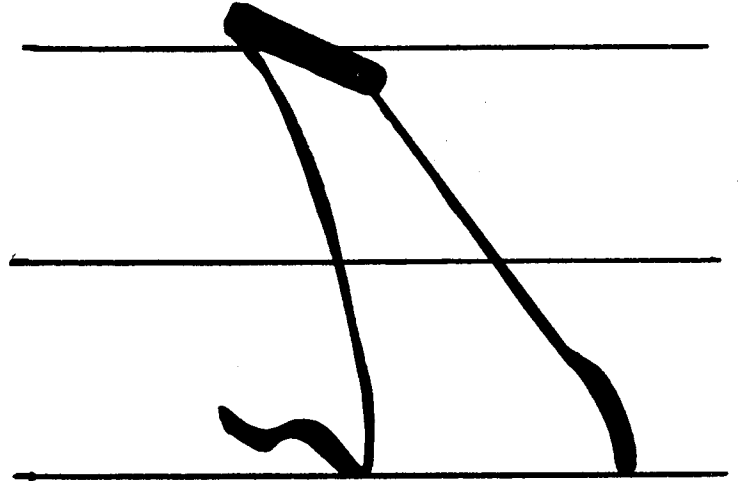
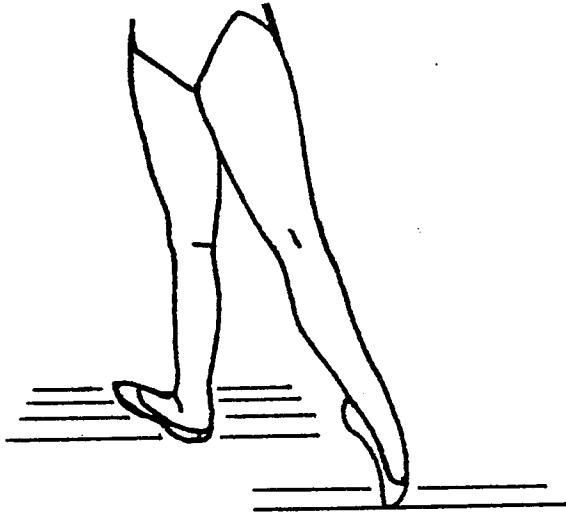

# ARMS ON DIAGONAL PLANE

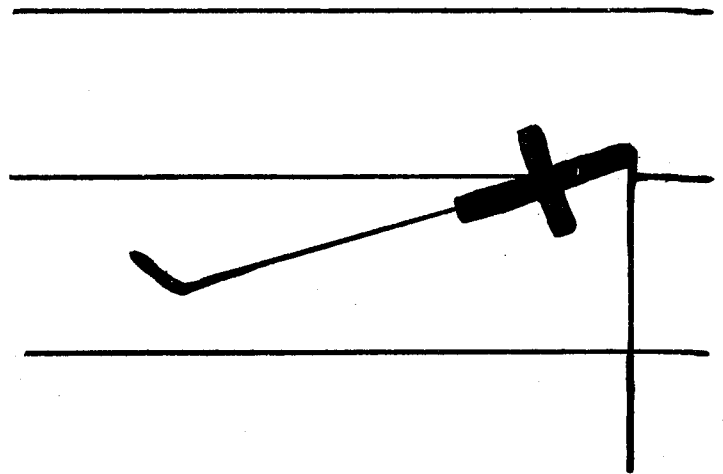
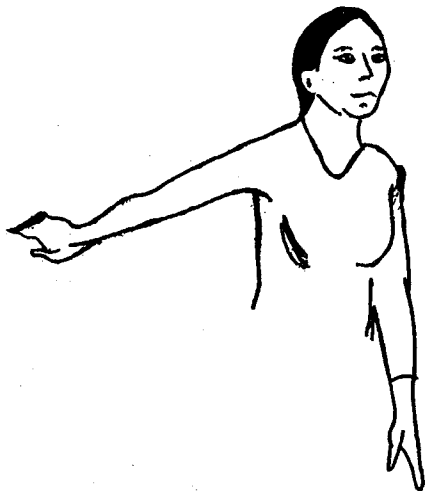
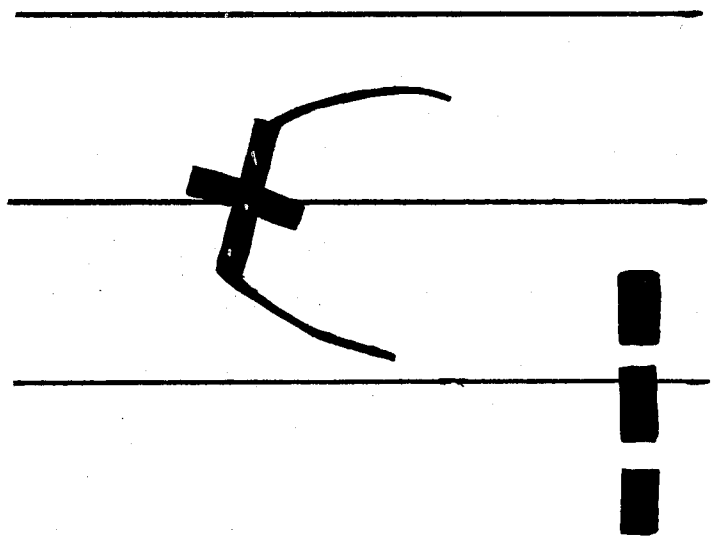
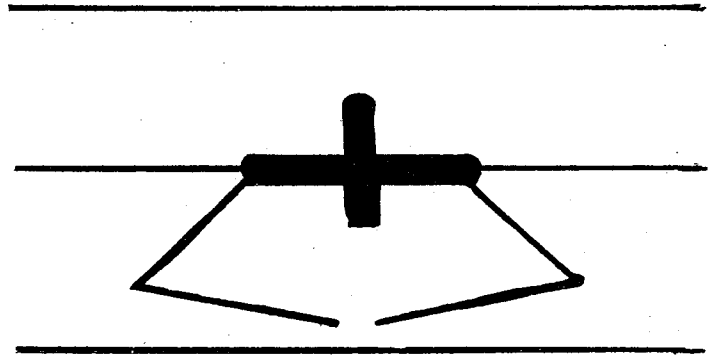
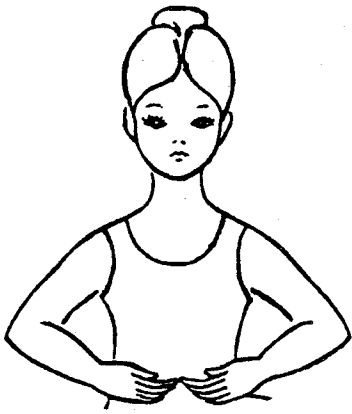

# LIMBS ON DIAGONAL PLANE

The following figures have limbs extending on the Diagonal Planes of the room.

In rare cases the limbs on the Diagonal Planes of the room may possibly appear to be extending on another plane of the room. On pages 105-144 Position Symbols, round symbols written below the five-lined staff, clarify any misunderstandings for the reader. The Position Symbols act as a double check on the stick figure and show the complete third dimension, adding 100% accuracy to all drawings.

Facing Front Wall

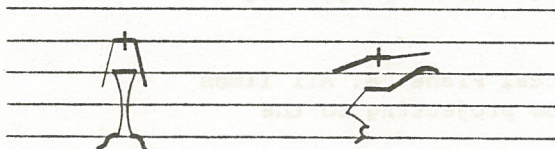

Facing Front Corner Walls

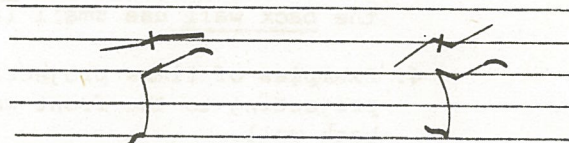

Facing Side Walls

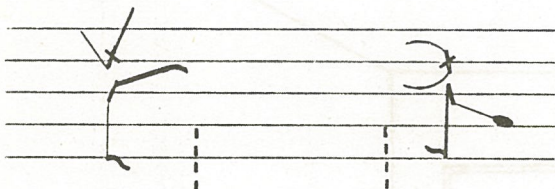

Facing Back Corner Walls

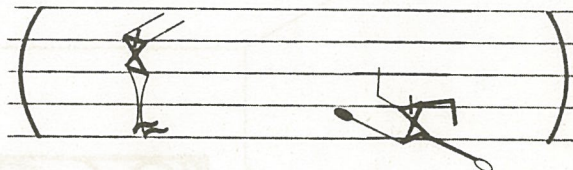

Facing Back Wall

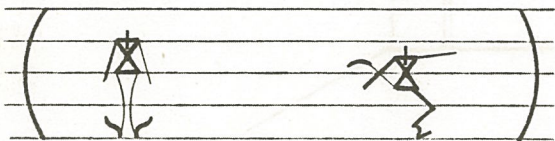

Facing Between Front Wall And Front Corner Walls

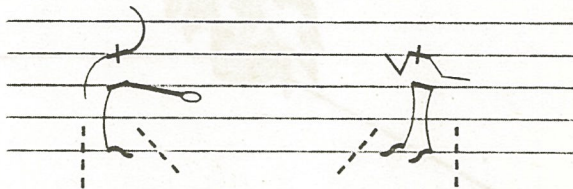

Facing Between Front Corner Walls And Side Walls

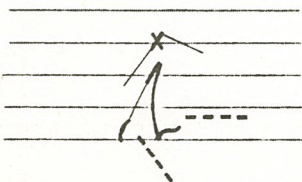

Facing Between Side Walls And Back Corner Walls



Facing Between Back Corner Walls And Back Wall

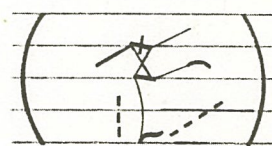

# THE SAGITTAL PLANE

1. The Sagittal Plane cuts the room from front wall to back wall, reaching from the ceiling to the floor.
2. It is difficult to draw limbs projecting on the Sagittal Plane. Dots and small lines are therefore used to represent limbs projecting on the Sagittal Plane.
3. Limbs projecting to the front wall use dots. Limbs projecting to the back wall use small lines.
4. Examples of limbs projecting on the Sagittal Plane: A. All limbs projecting to the front wall. B. All limbs projecting to the back wall.

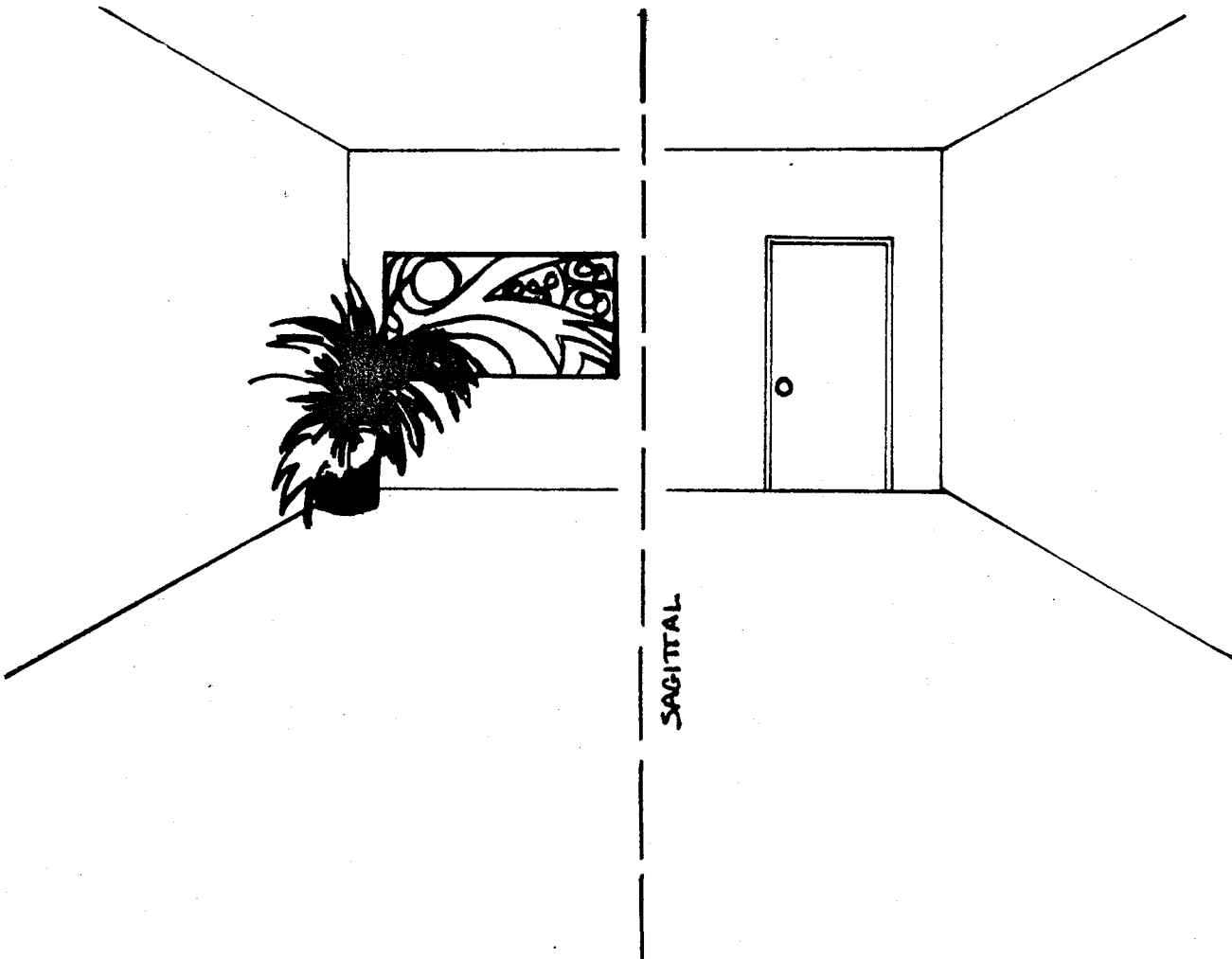



# FEET ON SAGITTAL PLANE

*Flat Feet To Front Wall*

*Flat Feet To Back Wall*

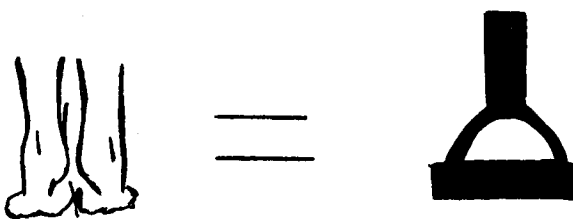
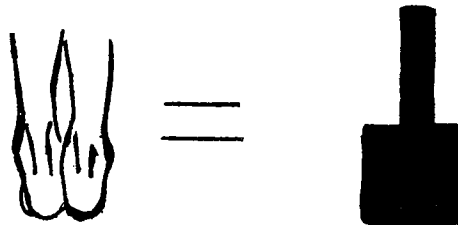
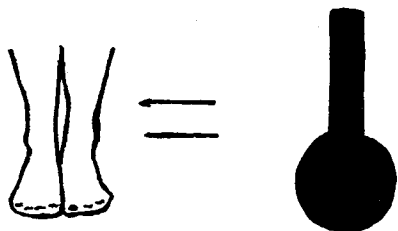

*Slight Raising Of Heels,  
Toes To Front Wall*

*Slight Raising Of Heels,  
Toes To Back Wall*

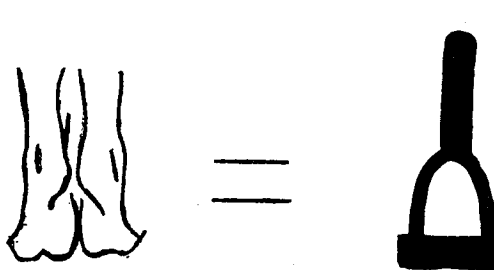
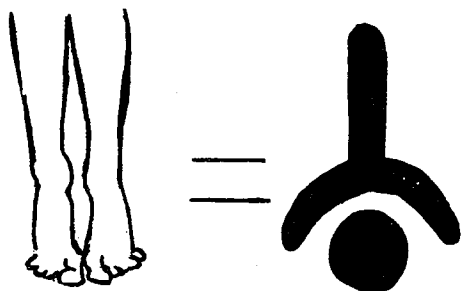

*Highest Raising Of Heels,  
Toes To Front Wall*

*Highest Raising Of Heels,  
Toes To Back Wall*

# LEGS ON SAGITTAL PLANE



When the lower limb projects on the Sagittal Plane of the room, to the front wall, the projection of the lower limb is represented by a dark dot. The dark dot is a picture of the bone of the limb projecting to the reader. When nothing else is written but the dark dot it means that the whole leg, led by the lower leg, projects on the Sagittal Plane. This writes the third dimension.

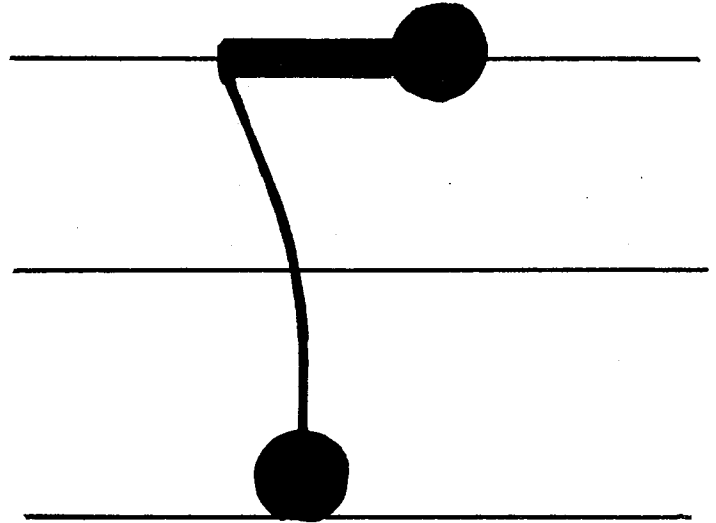

When the upper leg (thigh) projects on the Sagittal Plane of the room, to the front wall, the projection of the thigh is represented by a hollow dot written at knee level. This circle for the knee shows the third dimension of the thigh directed toward the audience. Without the hollow circle the knee would be projecting on the Frontal Plane of the room.

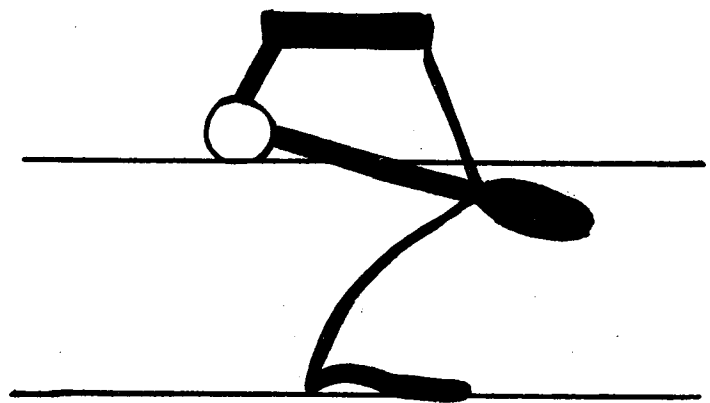
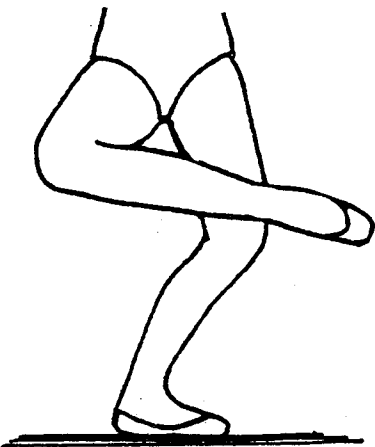

# LEGS ON SAGITTAL PLANE

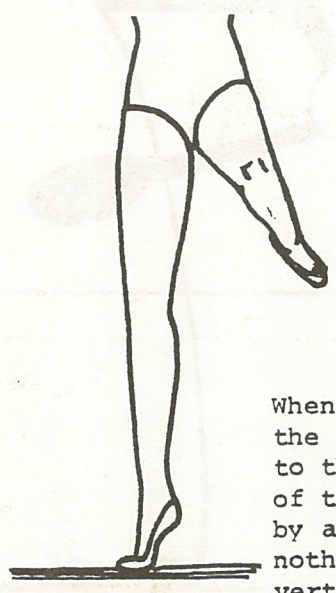

When the lower limb projects on the Sagittal Plane of the room, to the back wall, the projection of the lower limb is represented by a small, vertical line. When nothing else is written but the vertical line it means that the whole leg, led by the lower leg, projects on the Sagittal Plane. This writes the third dimension.

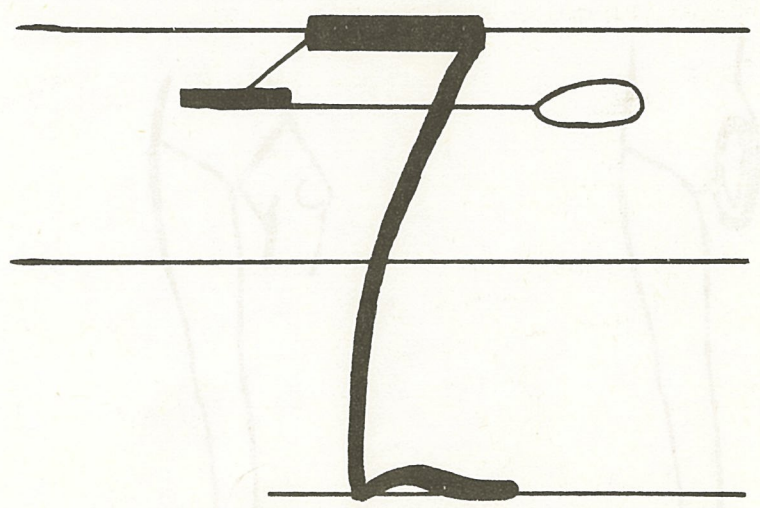
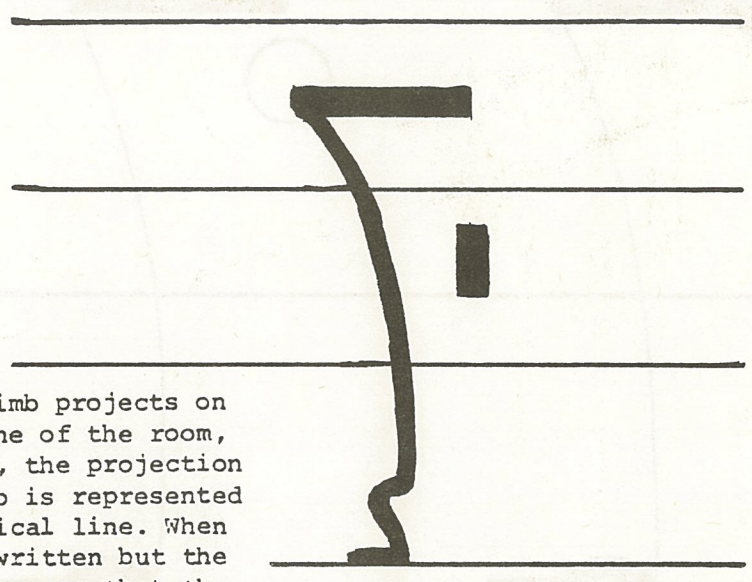

When the upper leg (thigh) projects on the Sagittal Plane of the room, to the back wall, the projection of the thigh is represented by a horizontal line written across the knee. This "crease" in the knee shows the third dimension of the thigh directed toward the back wall. Without the "crease line", the knee would be projecting on the Frontal Plane of the room.

# LEGS ON SAGITTAL PLANE

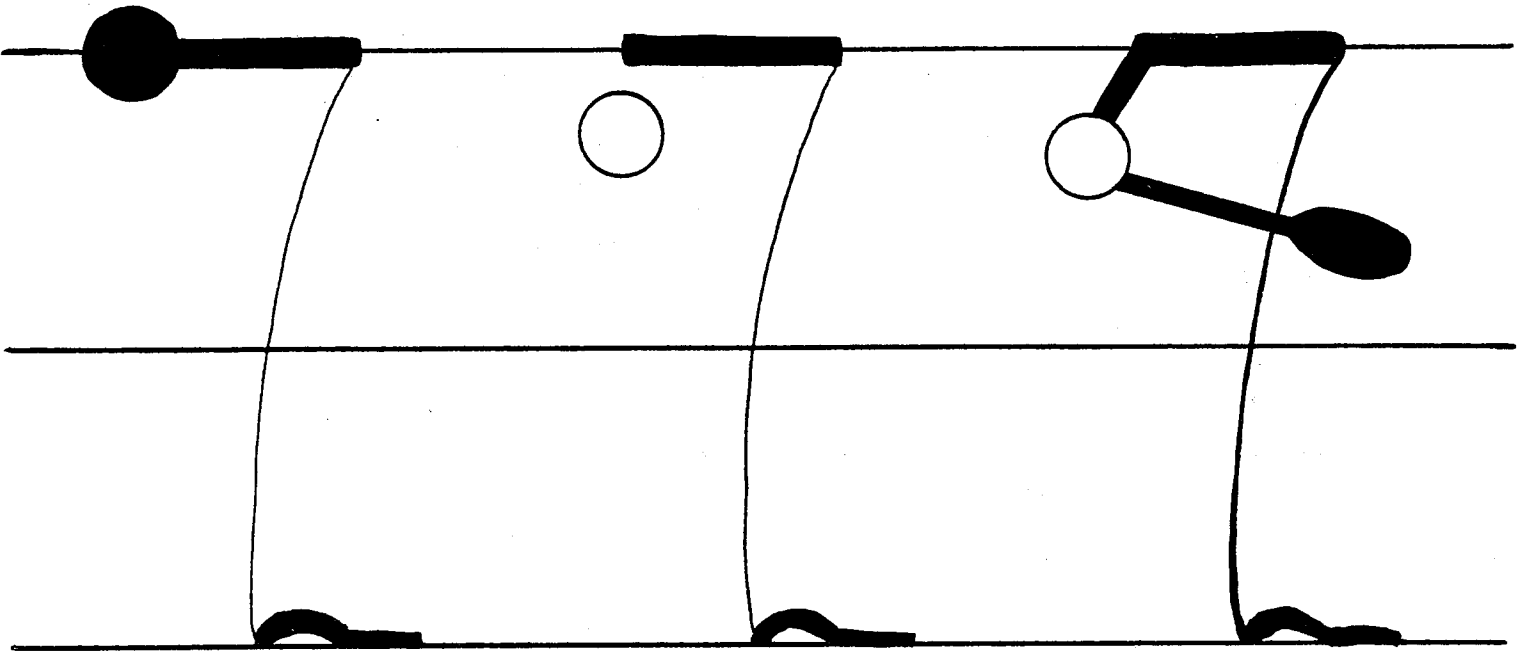

## LEGS TO FRONT WALL ON SAGITTAL PLANE OF ROOM

*Leg Straight.  
On Sagittal Plane*

*Leg Relaxed  
On Sagittal Plane*

*Leg Bent  
On Sagittal Plane*

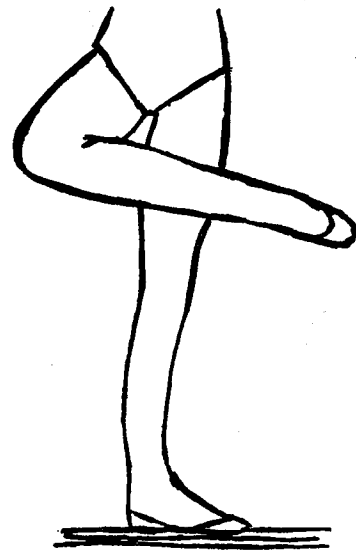
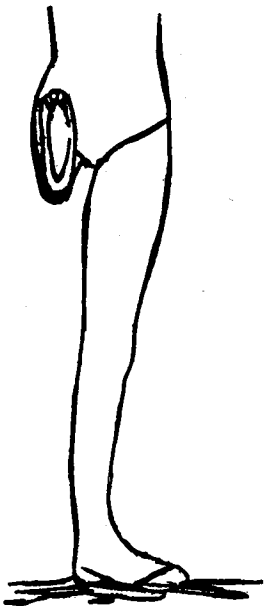

# LEGS ON SAGITTAL PLANE

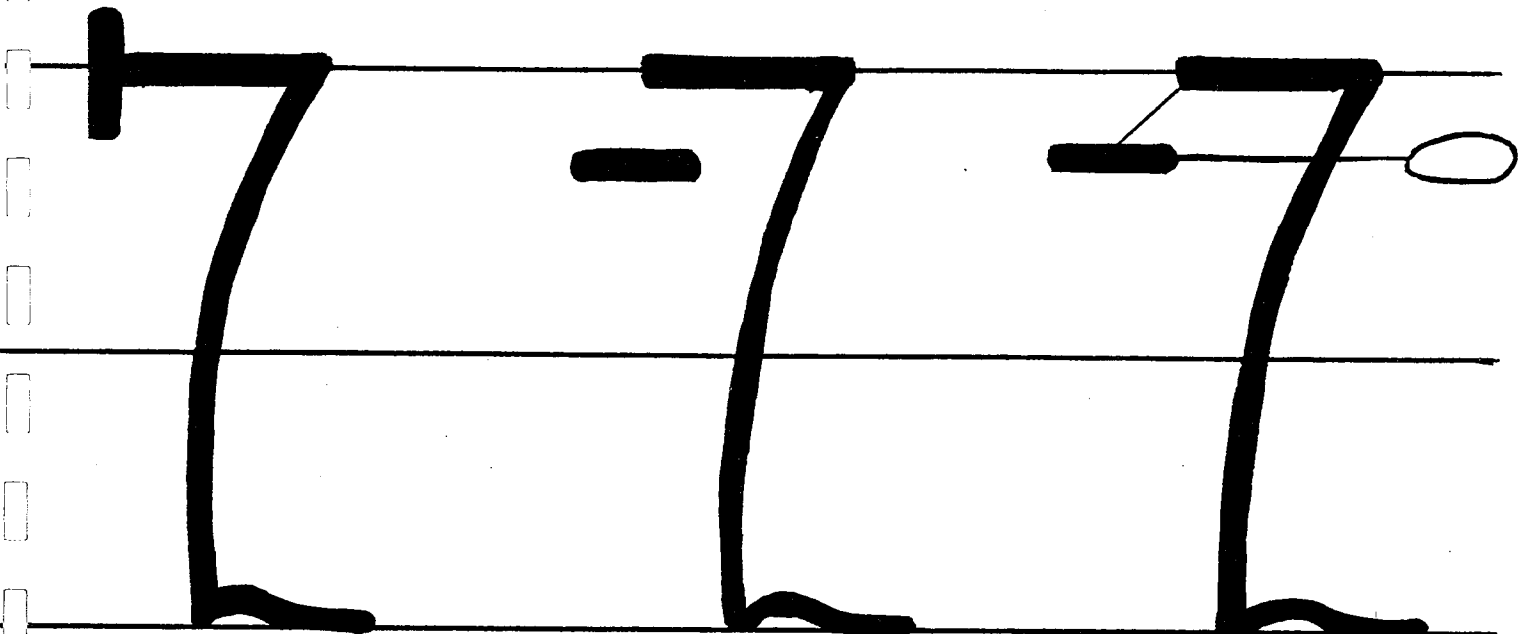

## LEGS TO BACK WALL ON SAGITTAL PLANE OF ROOM

*Leg Straight  
On Sagittal Plane*

*Leg Relaxed  
On Sagittal Plane*

*Leg Bent  
On Sagittal Plane*

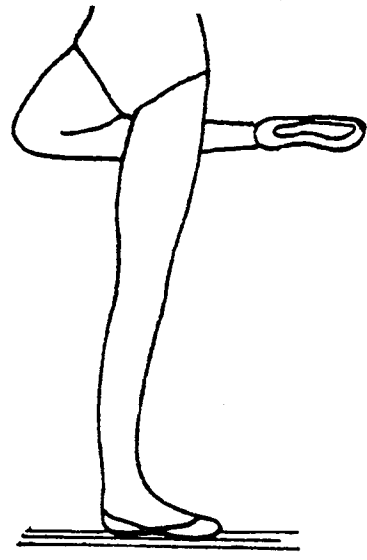
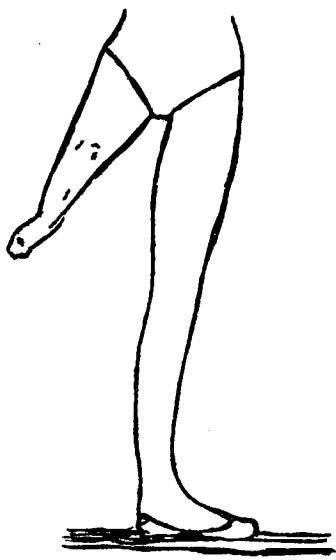

# LEGS ON SAGITTAL PLANE

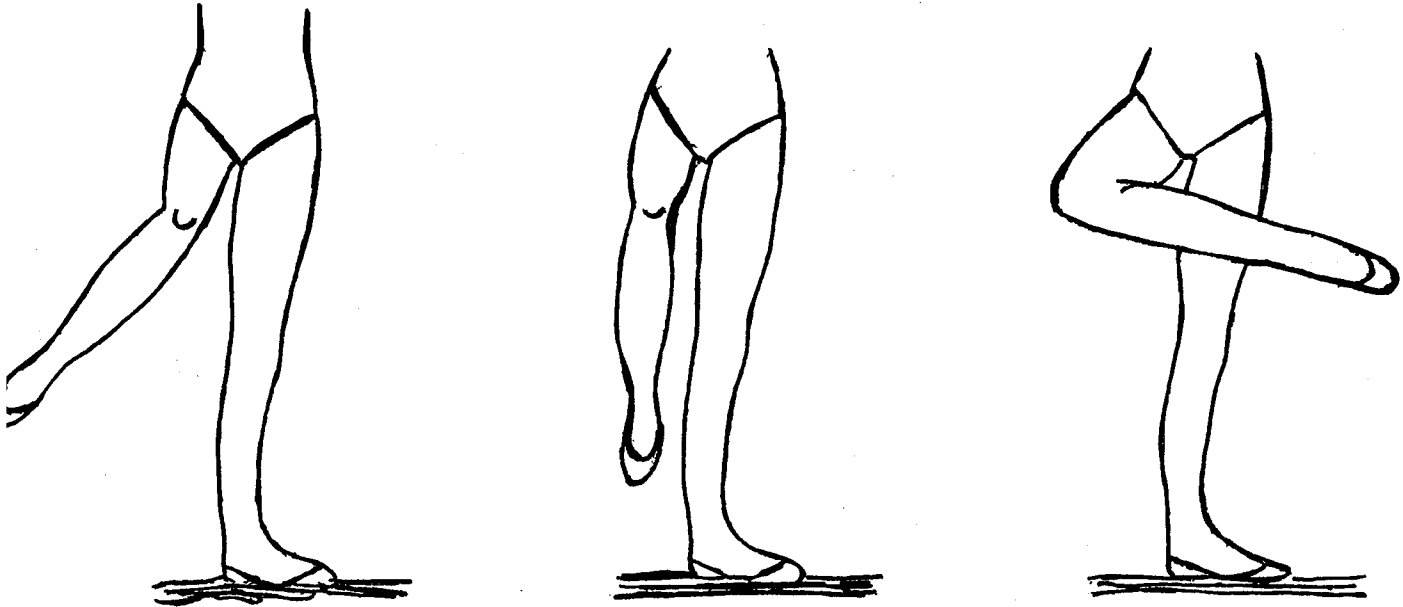
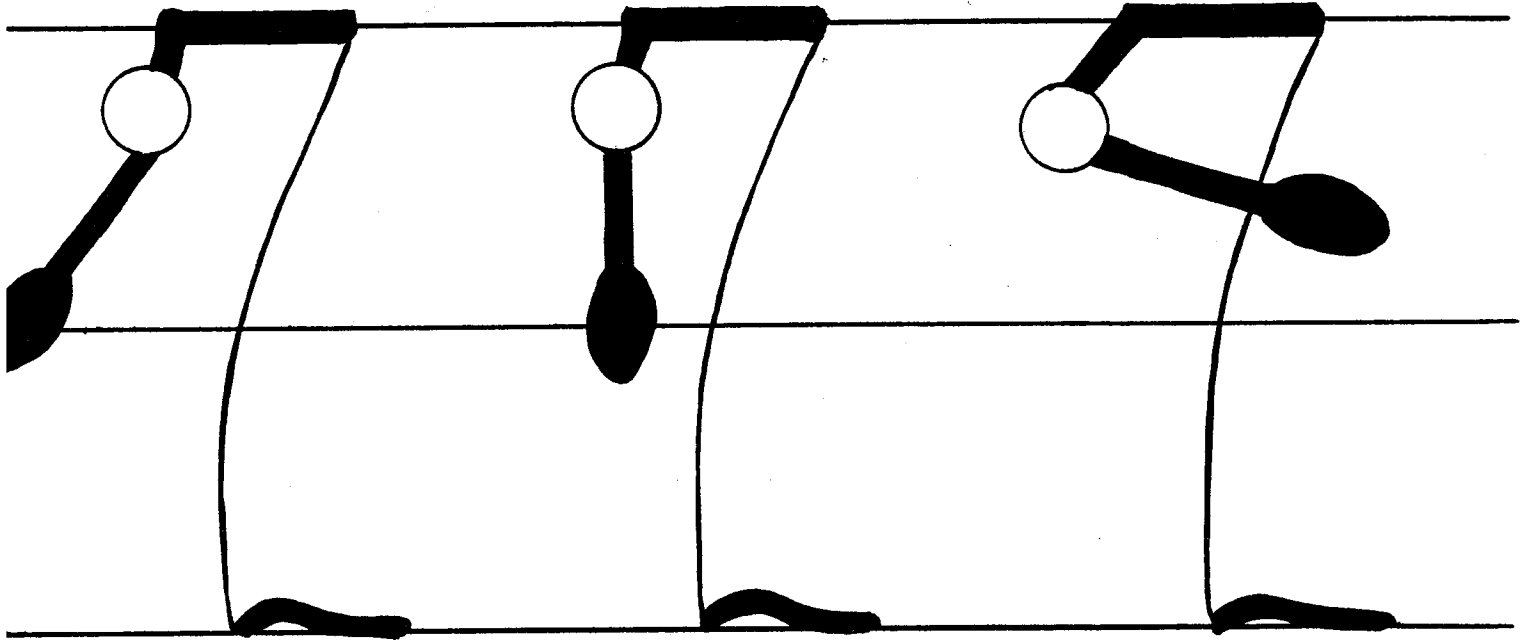

# LEGS ON SAGITTAL PLANE

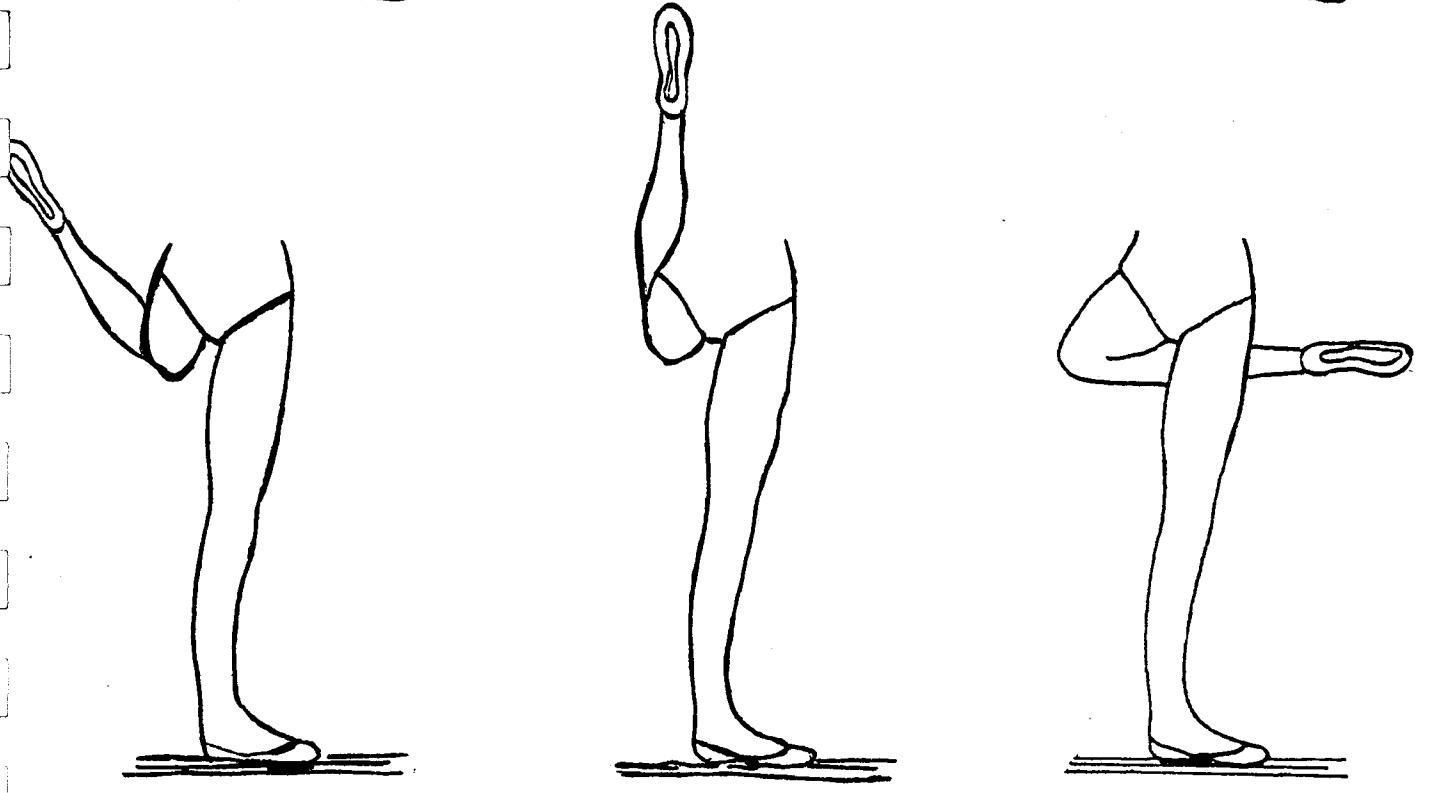
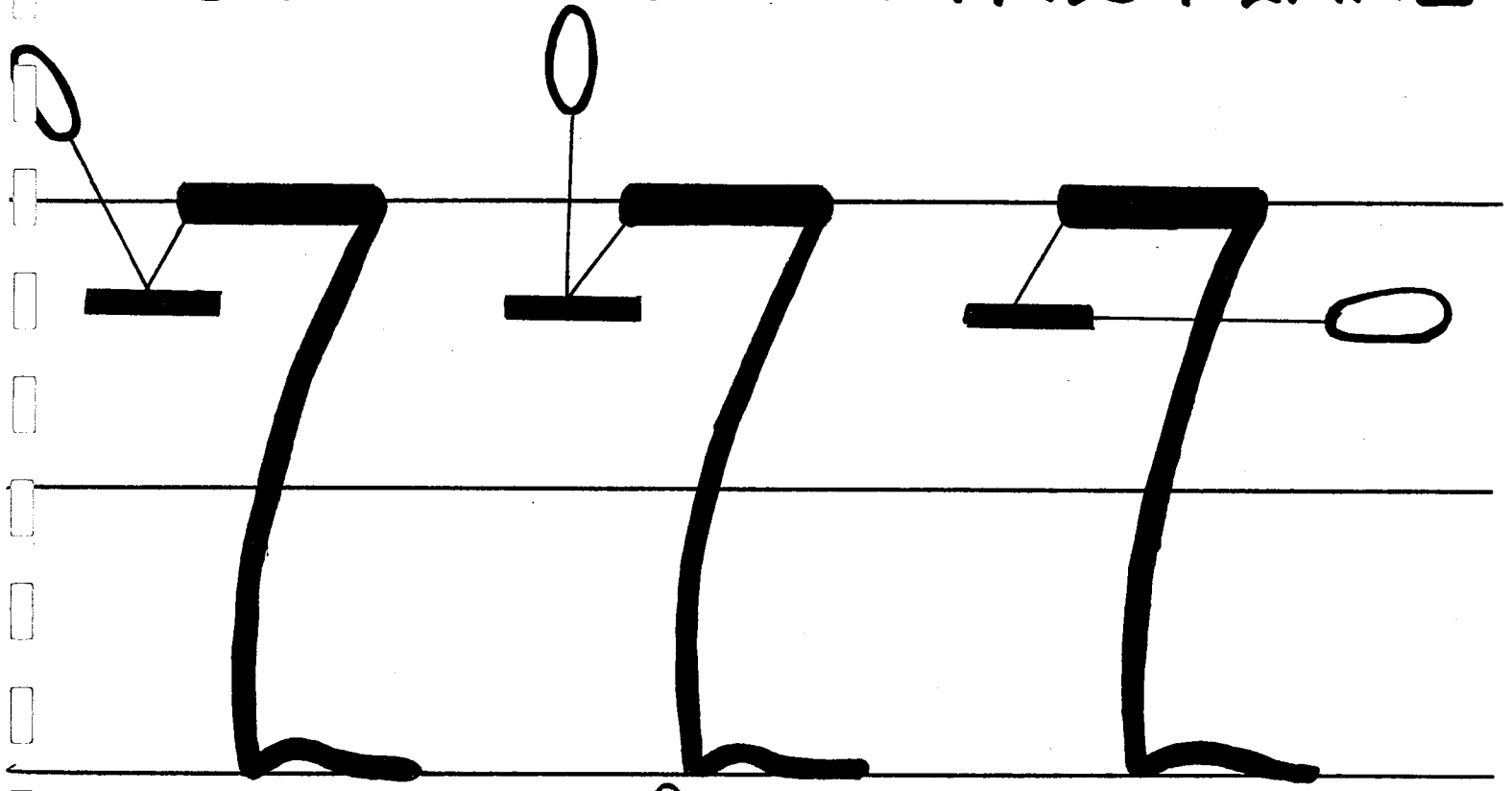

# LEGS ON SAGITTAL PLANE

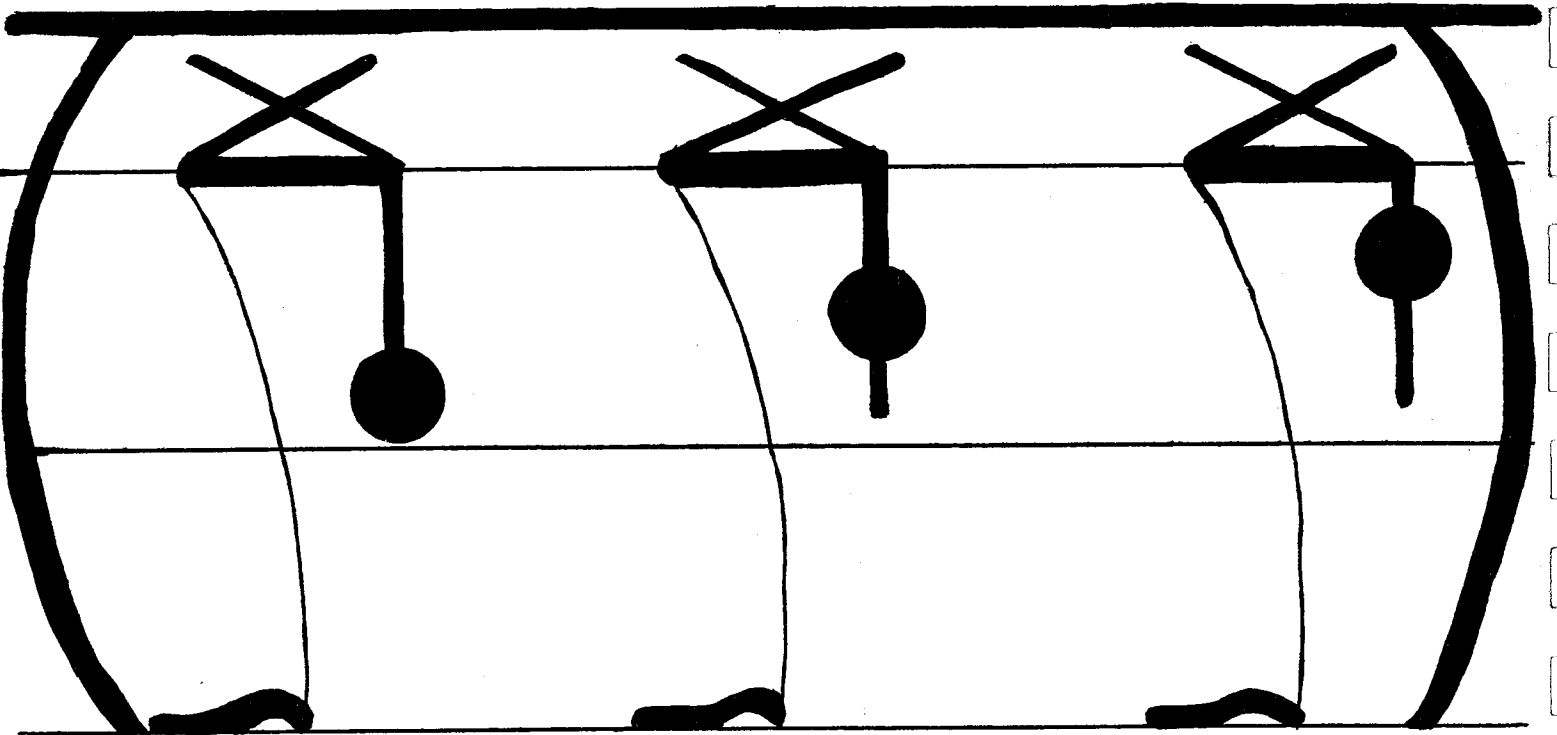
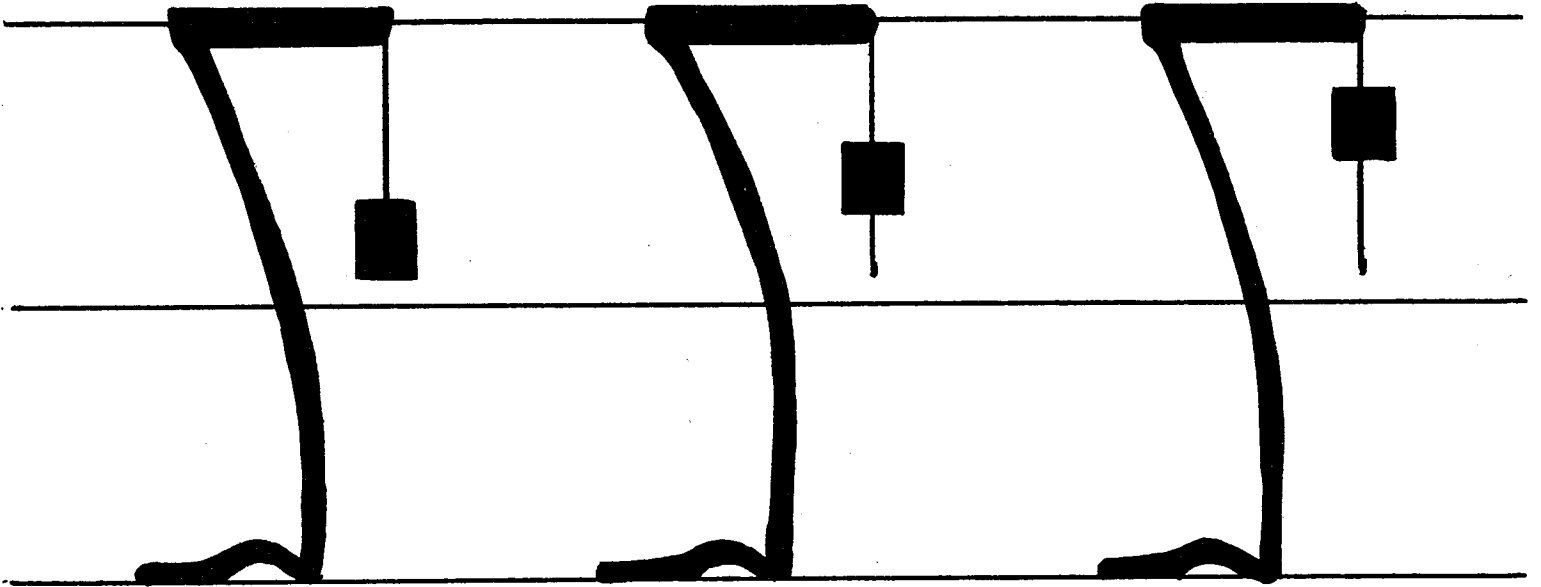



# LEGS ON SAGITTAL PLANE

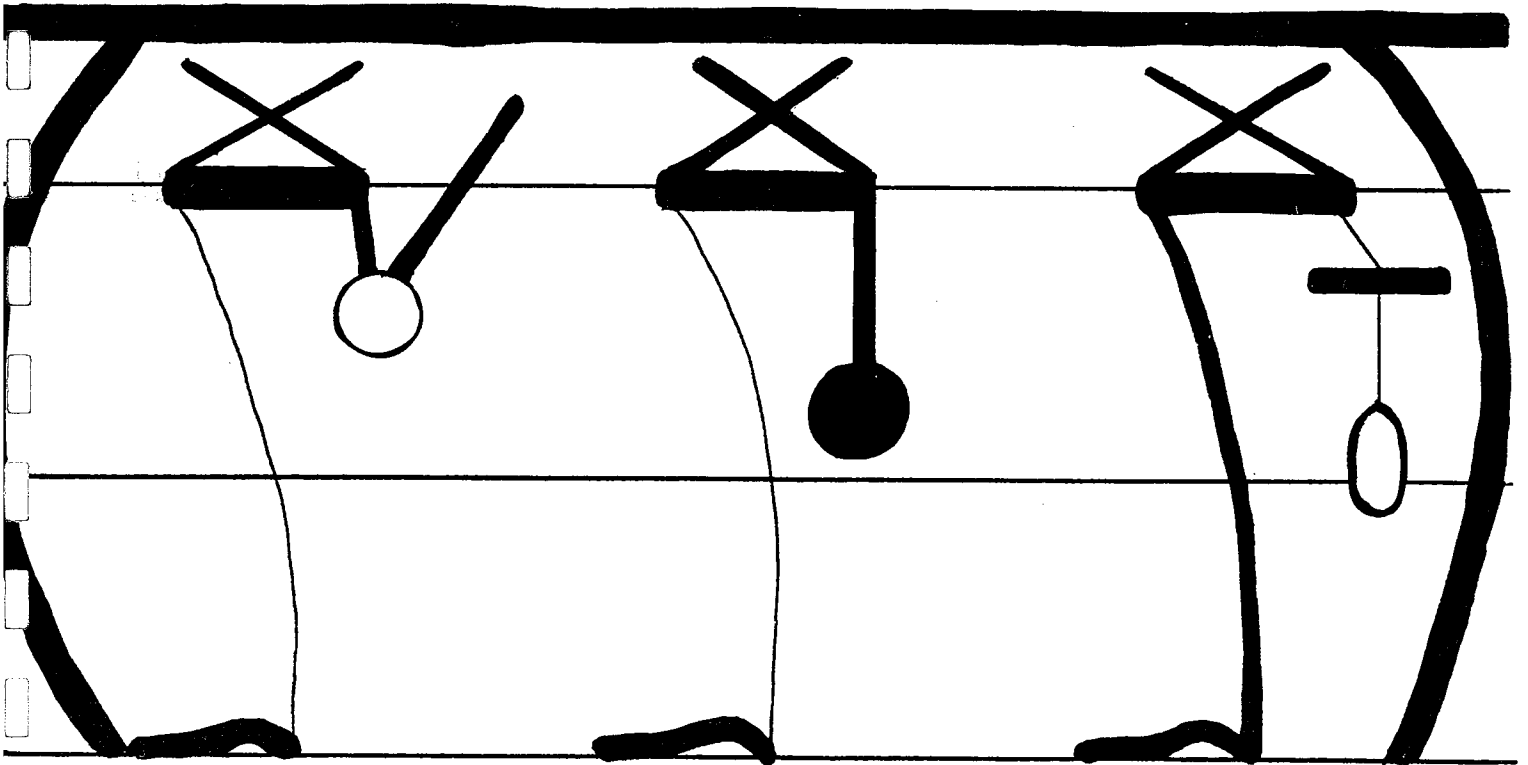
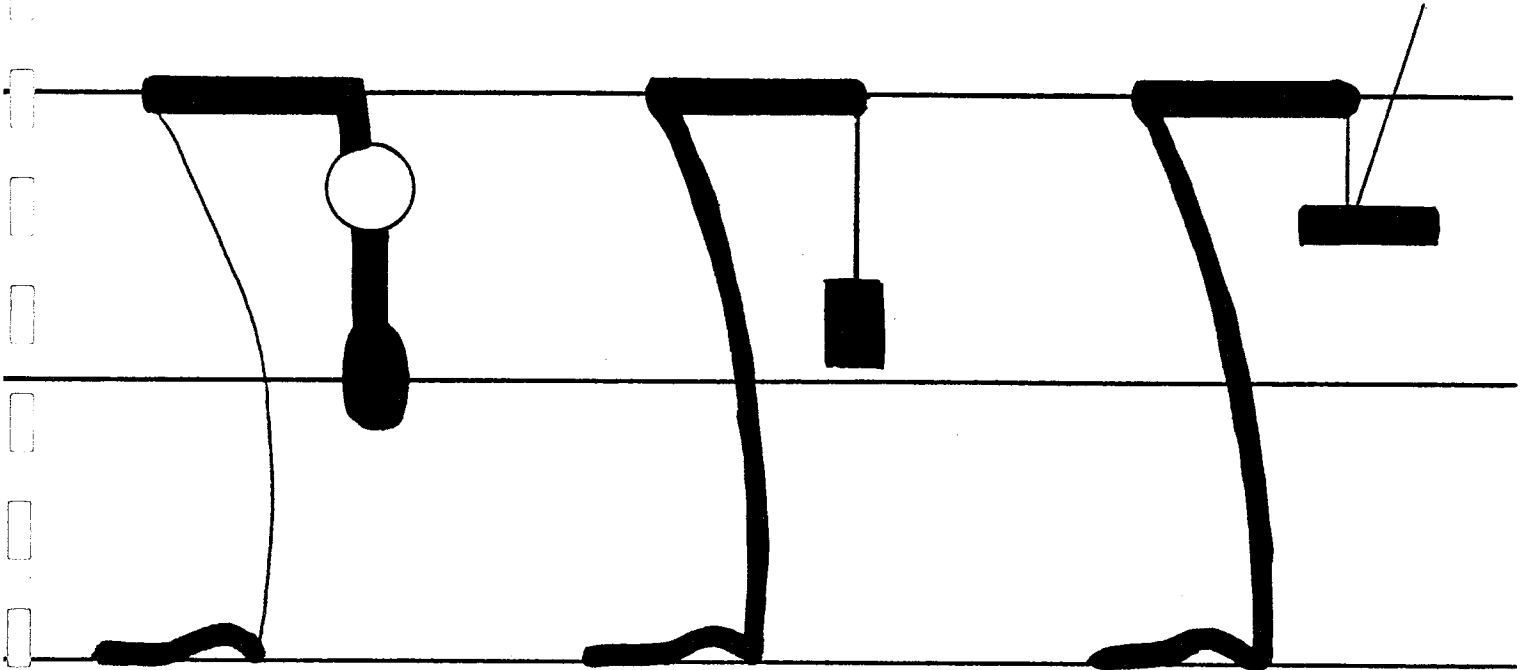

# BENT LIMBS - SAGITTAL PLANE

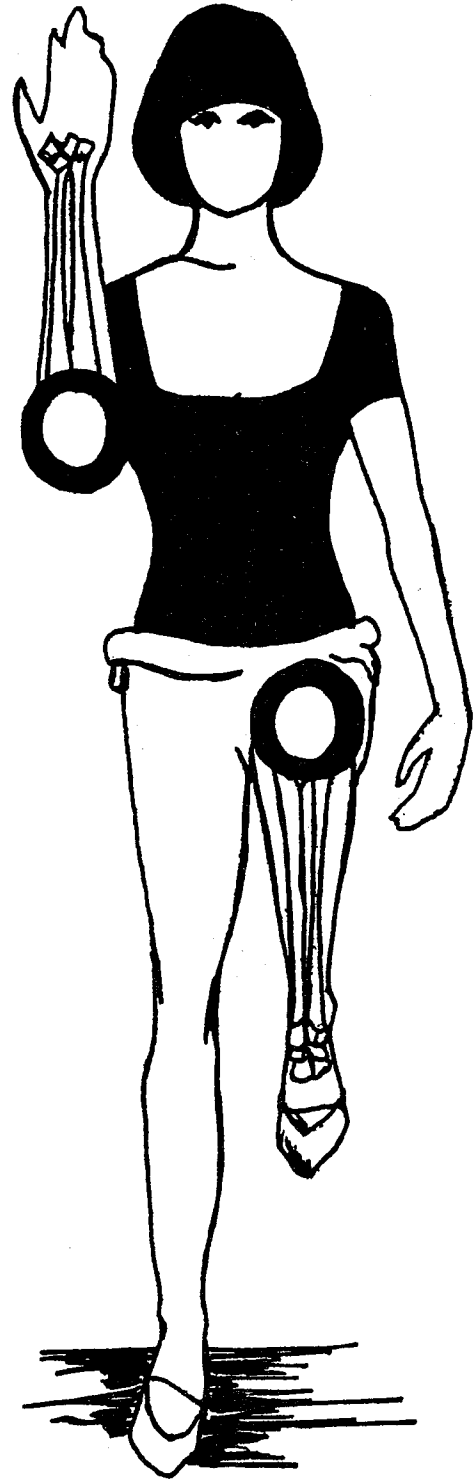
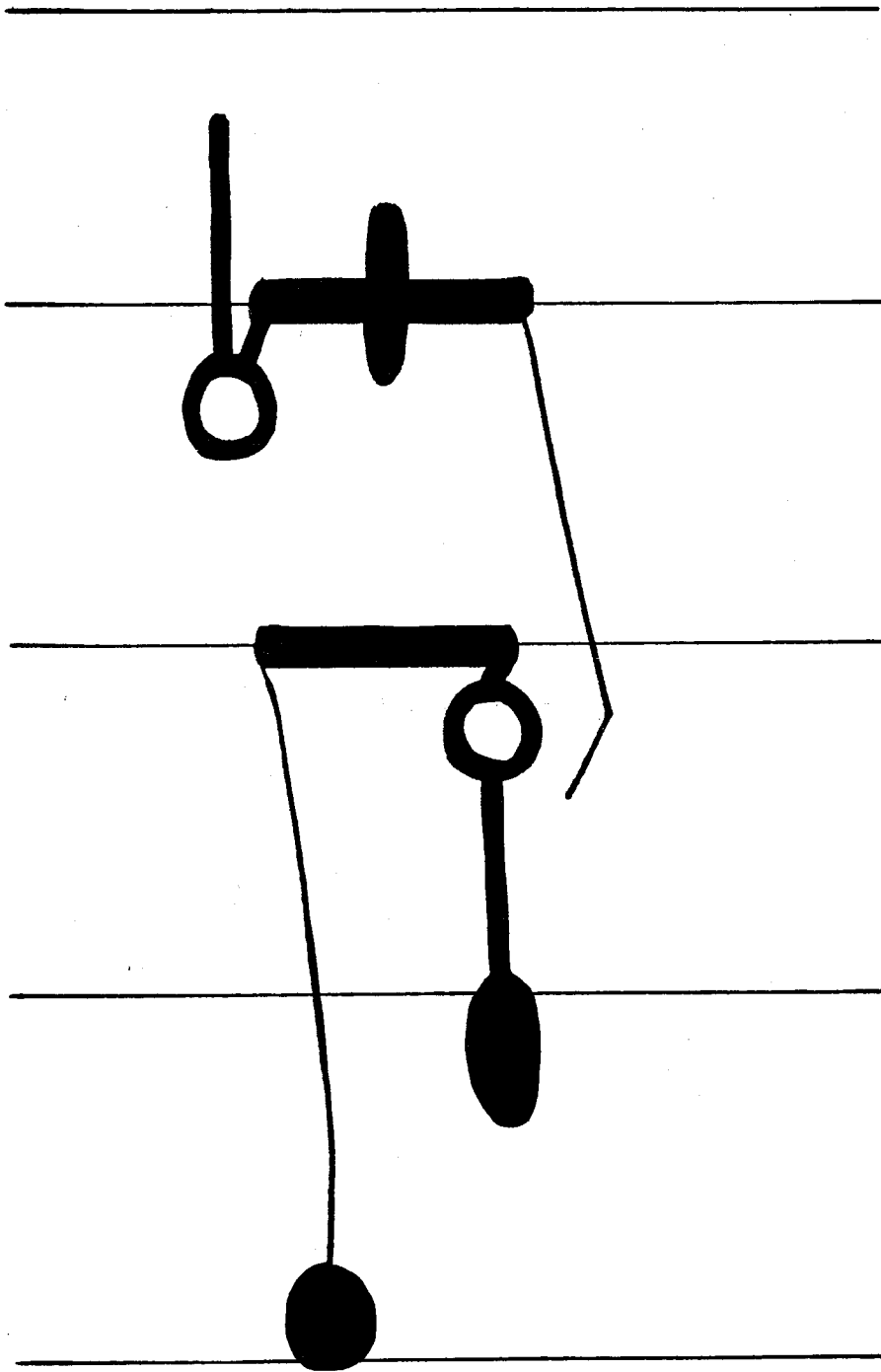

# ARMS ON SAGITTAL PLANE

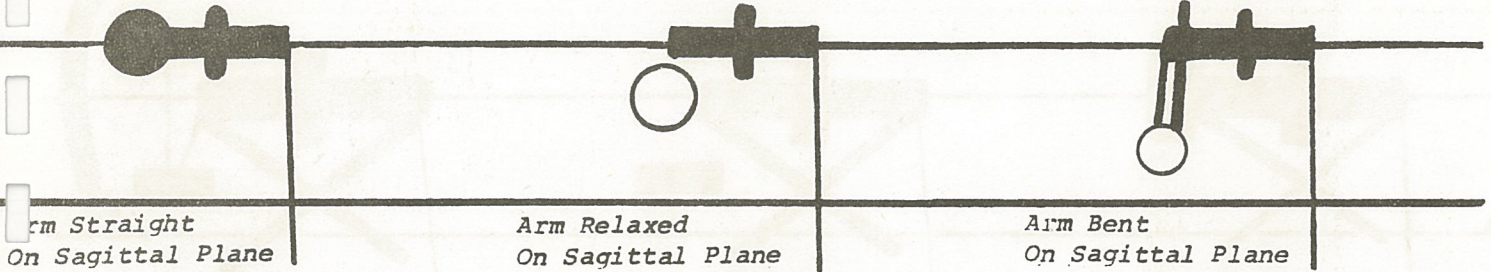

Arm Straight  
On Sagittal Plane

Arm Relaxed  
On Sagittal Plane

Arm Bent  
On Sagittal Plane



1. The dot is used to represent the projection of limbs on the Sagittal Plane.

2. The limbs are drawn-in, without dots, when projecting on the Frontal Plane.

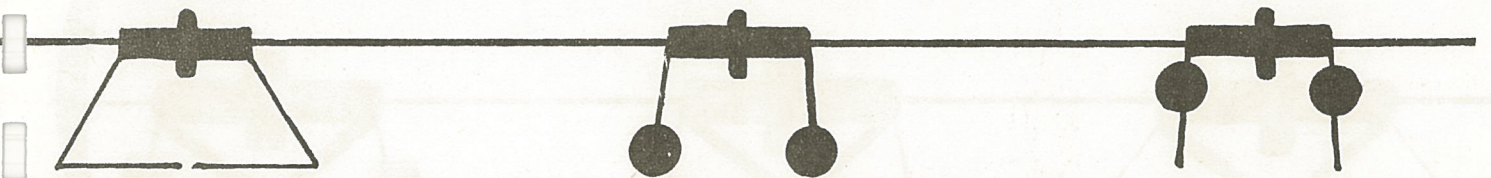

Arms Bent On  
Frontal Plane

Upper Arm On Frontal Plane  
Lower Arm On Sagittal Plane

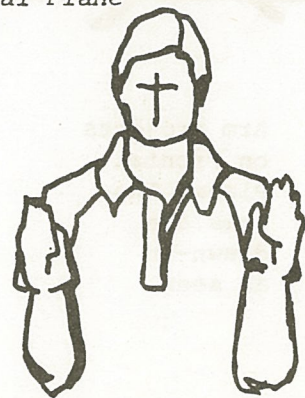
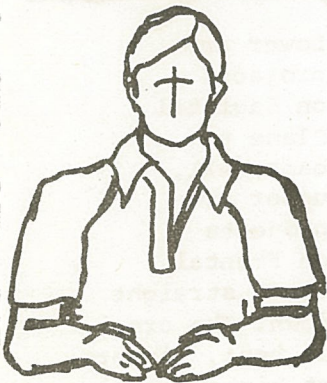

# ARMS ON SAGITTAL PLANE

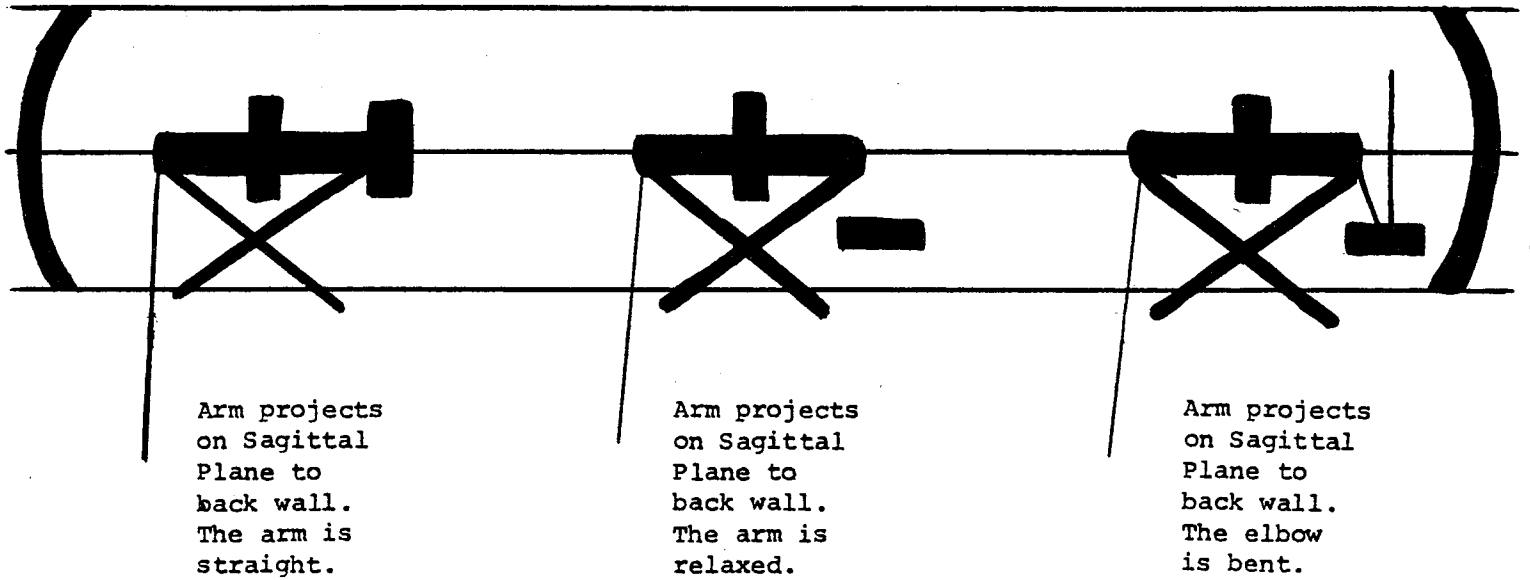

1. The vertical and horizontal lines are used to represent the projection of limbs on the Sagittal Plane.

2. The limbs are drawn-in, without small lines, when projecting on the Frontal Plane.

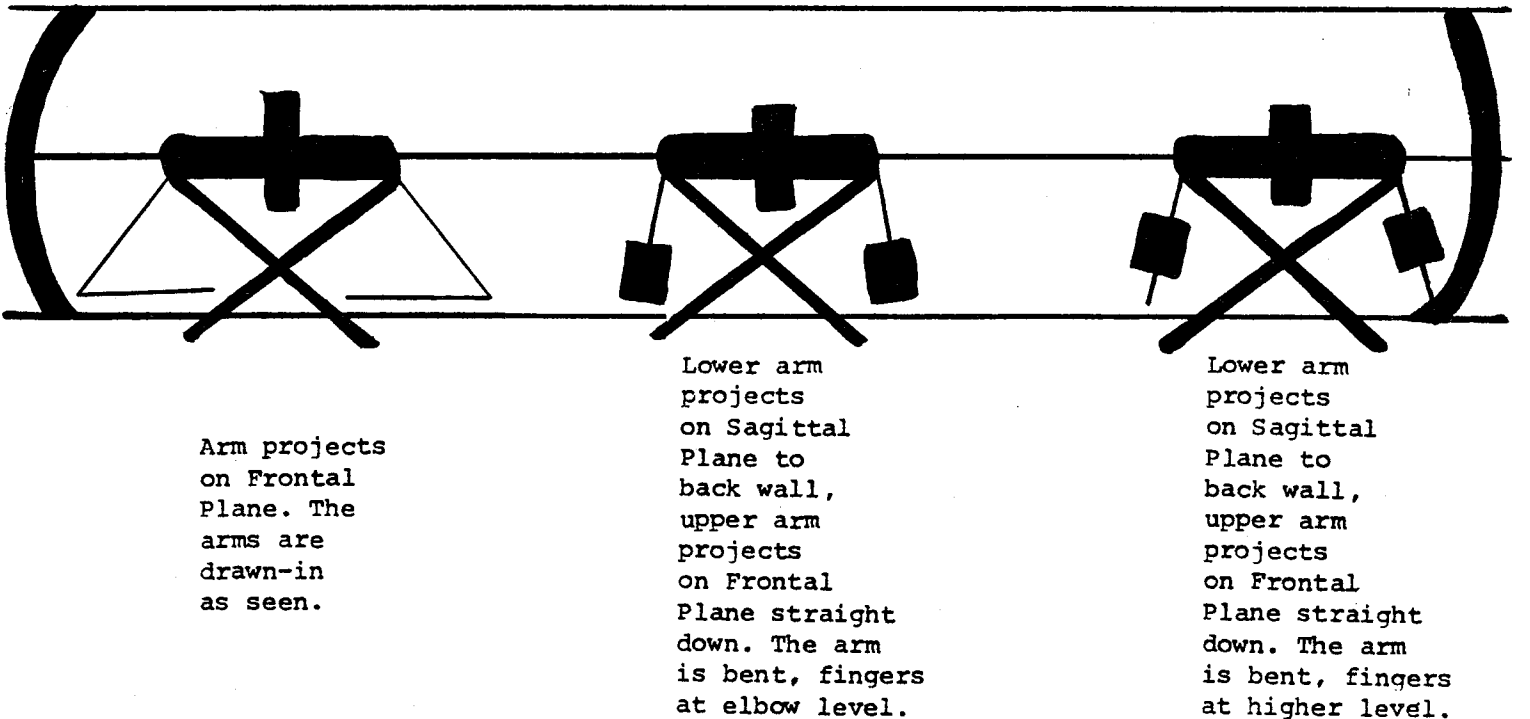

# LIMB DIRECTIONS

TO THE BACK  
(SAGITTAL PLANE)

BACK CORNER  
(DIAGONAL PLANE)



BACK CORNER  
(DIAGONAL PLANE)

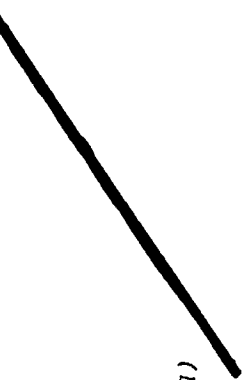

UP  
(FRONTAL PLANE)

Fingertips  
(Lower Arm)  
Toes  
(Lower Leg)

Elbow  
(Upper Arm)  
Knee  
(Thigh)



DOWN  
(FRONTAL PLANE)

SIDE WALL

(FRONTAL PLANE)



SIDE WALL

(FRONTAL PLANE)



Toes  
(Lower Leg)  
Fingertips  
(Lower Arm)

Knee  
(Thigh)  
Elbow  
(Upper Arm)



FRONT CORNER  
(DIAGONAL PLANE)

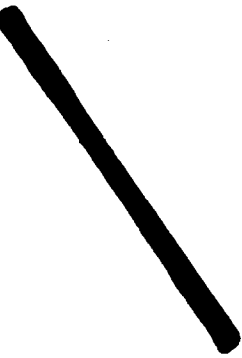

TO THE FRONT  
(SAGITTAL PLANE)

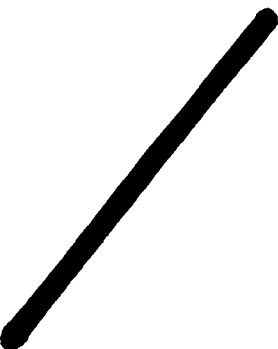

FRONT CORNER  
(DIAGONAL PLANE)

# LIMBS ON SAGITTAL PLANE

The following figures have limbs extending on the Sagittal Plane of the room.

On pages 105-144 Position Symbols, round symbols written below the five-lined staff, clarify the positions for the reader. The Position Symbols act as a double check on the stick figure and show the complete third dimension, adding 100% accuracy to all drawings.

Facing  
Front  
Wall

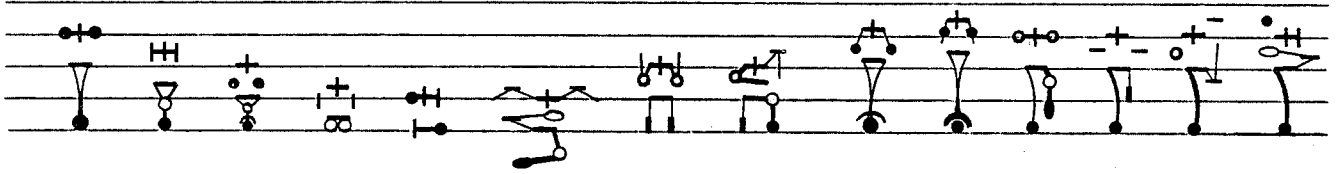

Facing  
Front  
Corner  
Walls

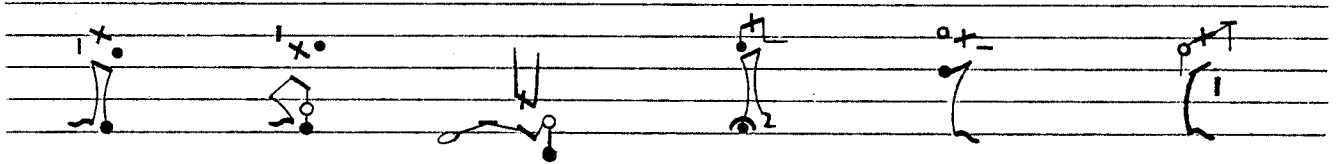

Facing  
Side  
Walls

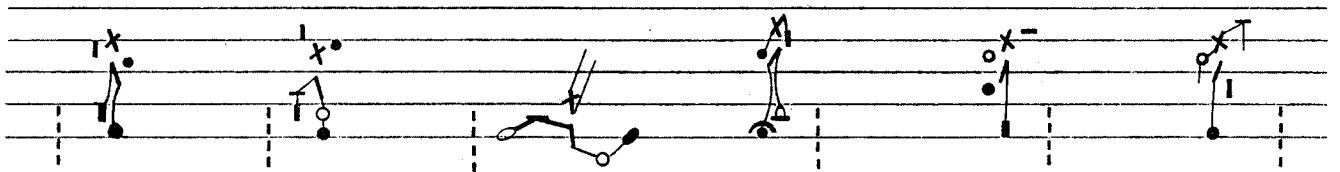

Facing  
Back  
Corner  
Walls

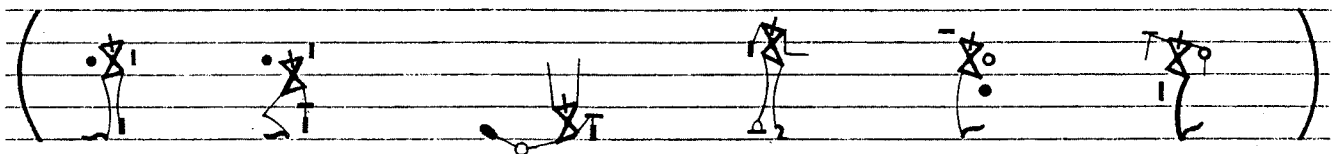



# LIMBS ON SAGITTAL PLANE

Facing  
Back  
Wall

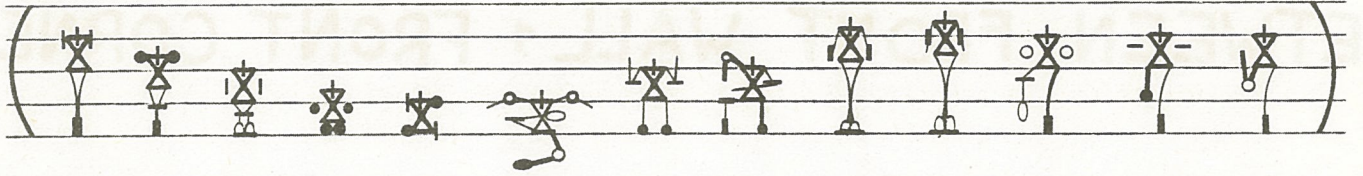

Facing  
Between  
Front  
Wall And  
Front  
Corner  
Walls

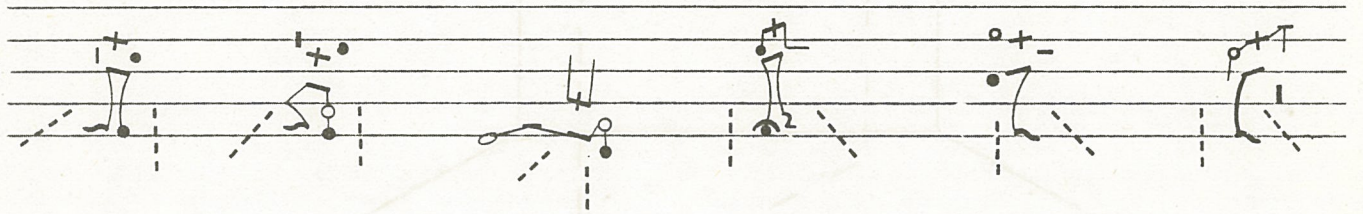

Facing  
Between  
Front  
Corner  
Walls And  
Side  
Walls

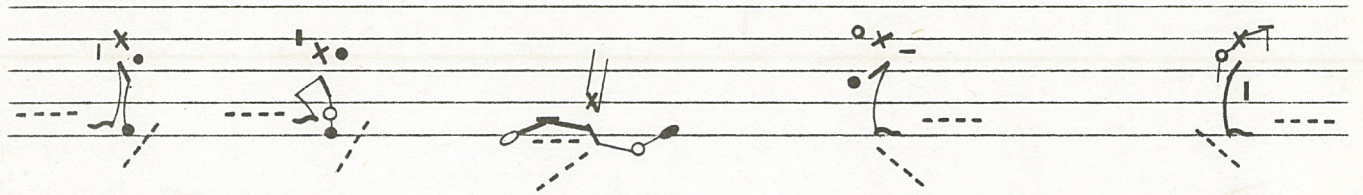

Facing  
Between  
Side  
Walls And  
Back  
Corner  
Walls

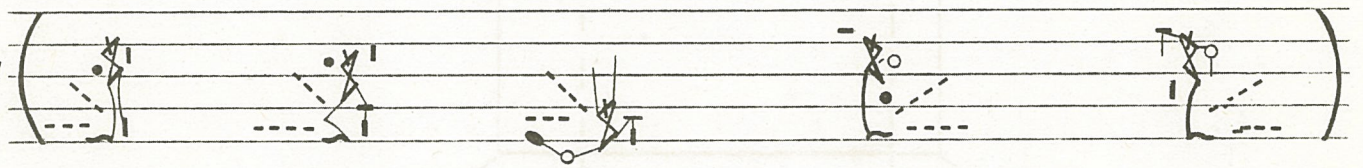

Facing  
Between  
Back  
Corner  
Walls And  
Back  
Wall

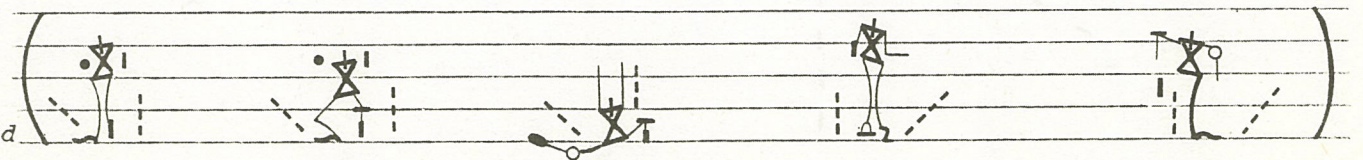

# THE IN-BETWEEN PLANES

## BETWEEN FRONT WALL + FRONT CORNER

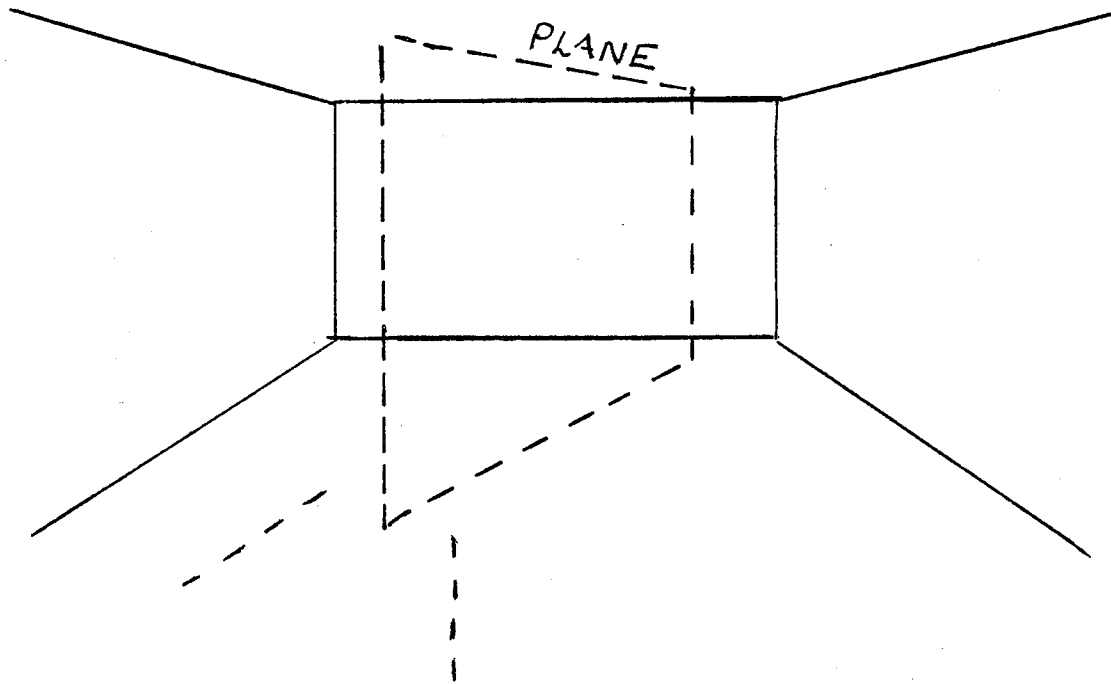
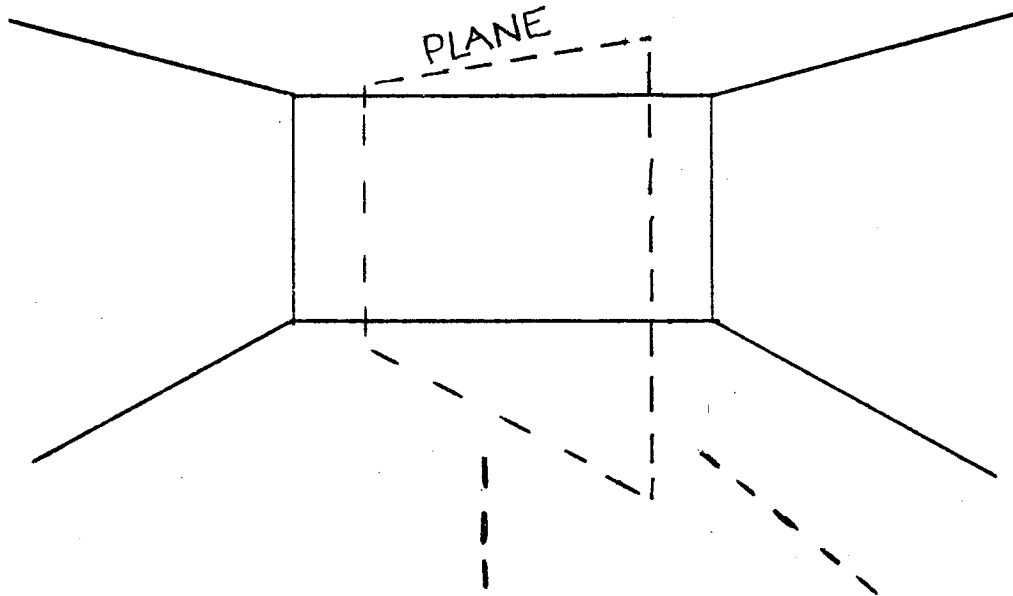



# LIMBS ON PLANE BETWEEN FRONT WALL & FRONT CORNER

The following figures have limbs extending on the plane between the front wall and the front corner wall.

On pages 105-144 Position Symbols, round symbols written below the five-lined staff, clarify the positions for the reader. The Position Symbols act as a double check on the stick figure and show the complete third dimension, adding 100% accuracy to all drawings.

Facing Front Wall

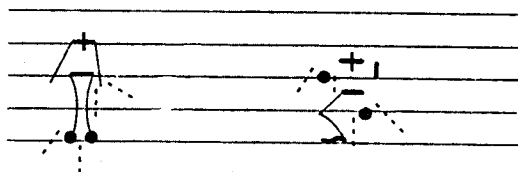

Facing Front Corner Walls

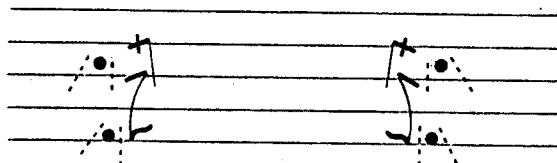

Facing Side Walls

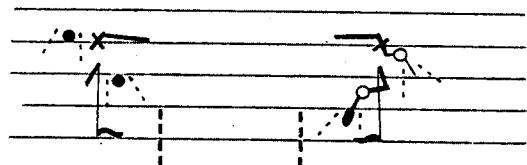

Facing Back Corner Walls

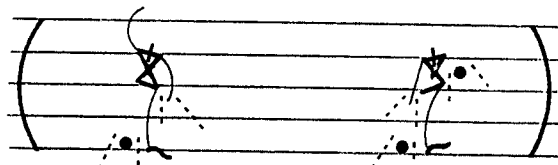

Facing Back Wall

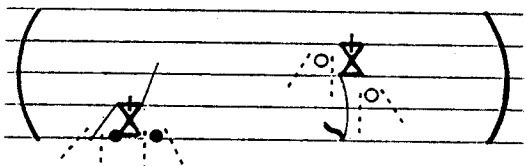

Facing Between Front Wall And Front Corner Walls

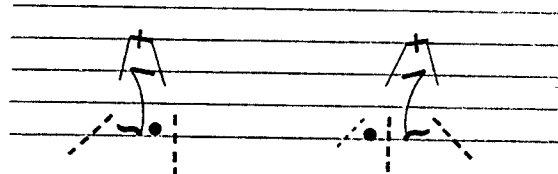

Facing Between Front Corner Walls And Side Walls

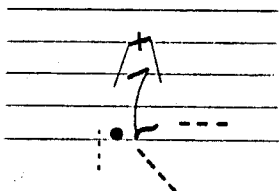

Facing Between Side Walls And Back Corner Walls



Facing Between Back Corner Walls And Back Wall

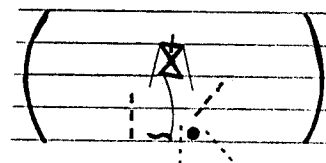

# BETWEEN FRONT CORNER & SIDE WALL

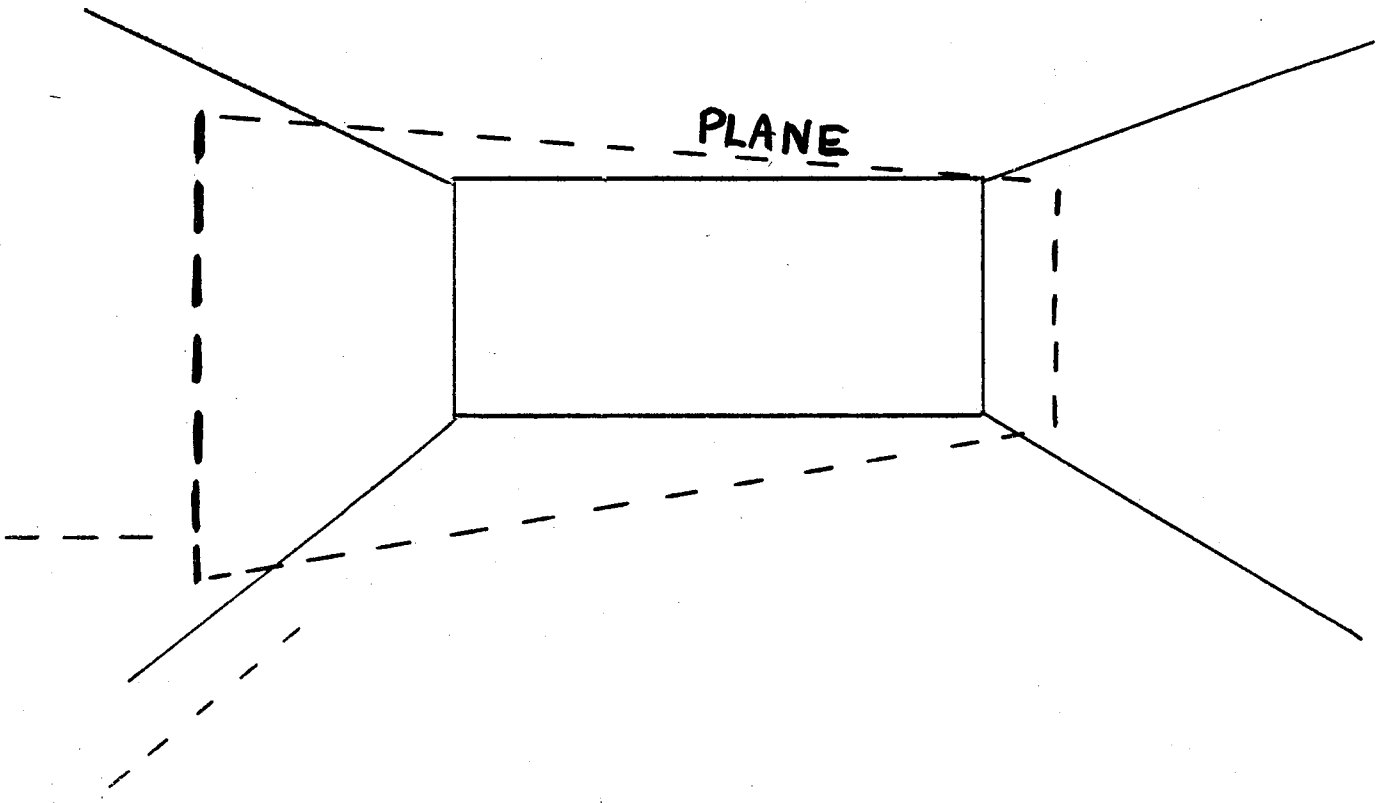
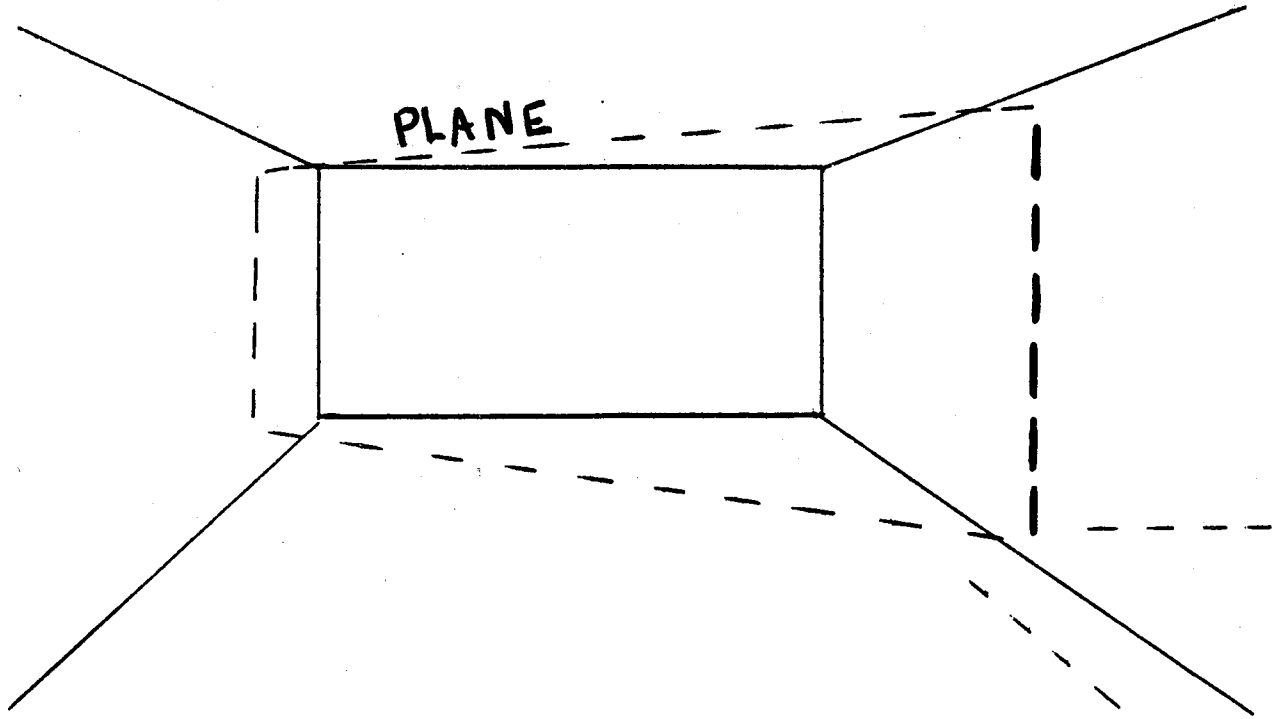

# LIMBS ON PLANE BETWEEN FRONT CORNER & SIDE WALL

The following figures have limbs extending on the plane between the front corner wall and the side wall.

On pages 105-144 Position Symbols, round symbols below the five-lined staff, clarify the positions for the reader. The Position Symbols act as a double check on the stick figure and show the complete third dimension, adding 100% accuracy to all drawings.

Facing Front Wall

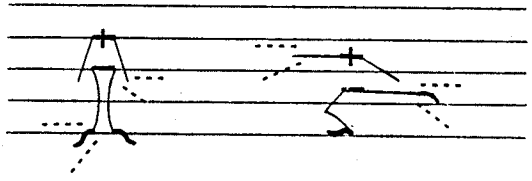

Facing Front Corner Walls

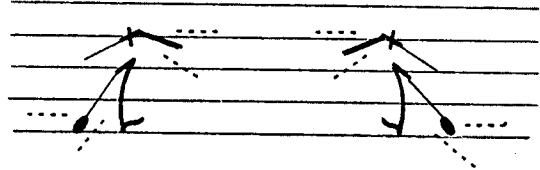

Facing Side Walls

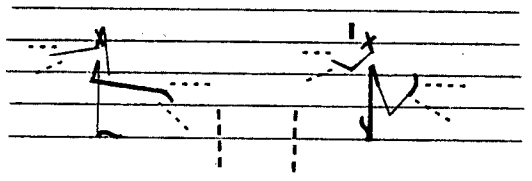

Facing Back Corner Walls

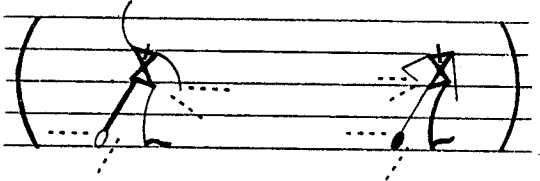

Facing Back Wall

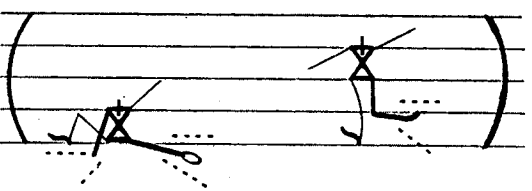

Facing Between Front Wall And Front Corner Walls

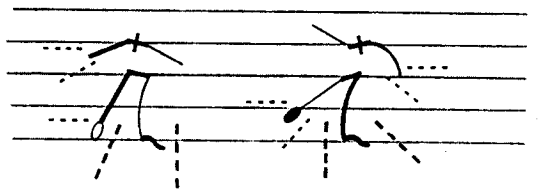

Facing Between Front Corner Walls And Side Walls

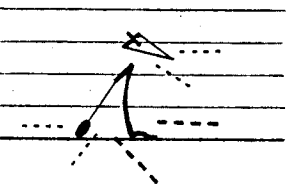

Facing Between Side Walls And Back Corner Walls

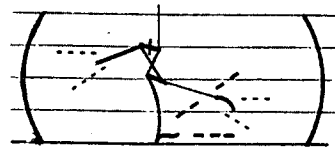

Facing Between Back Corner Walls And Back Wall

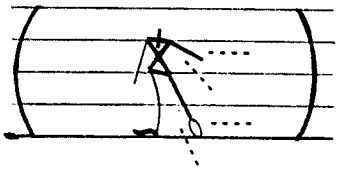

# BETWEEN SIDE WALL & BACK CORNER

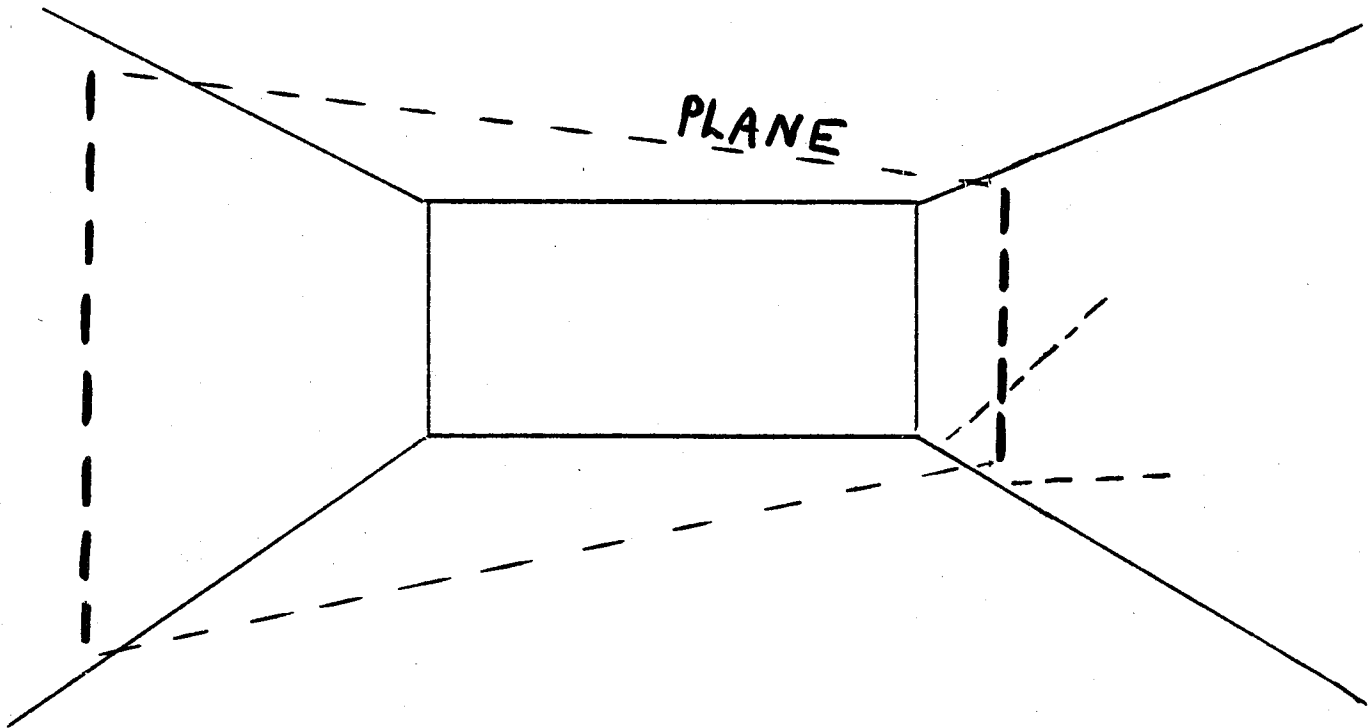
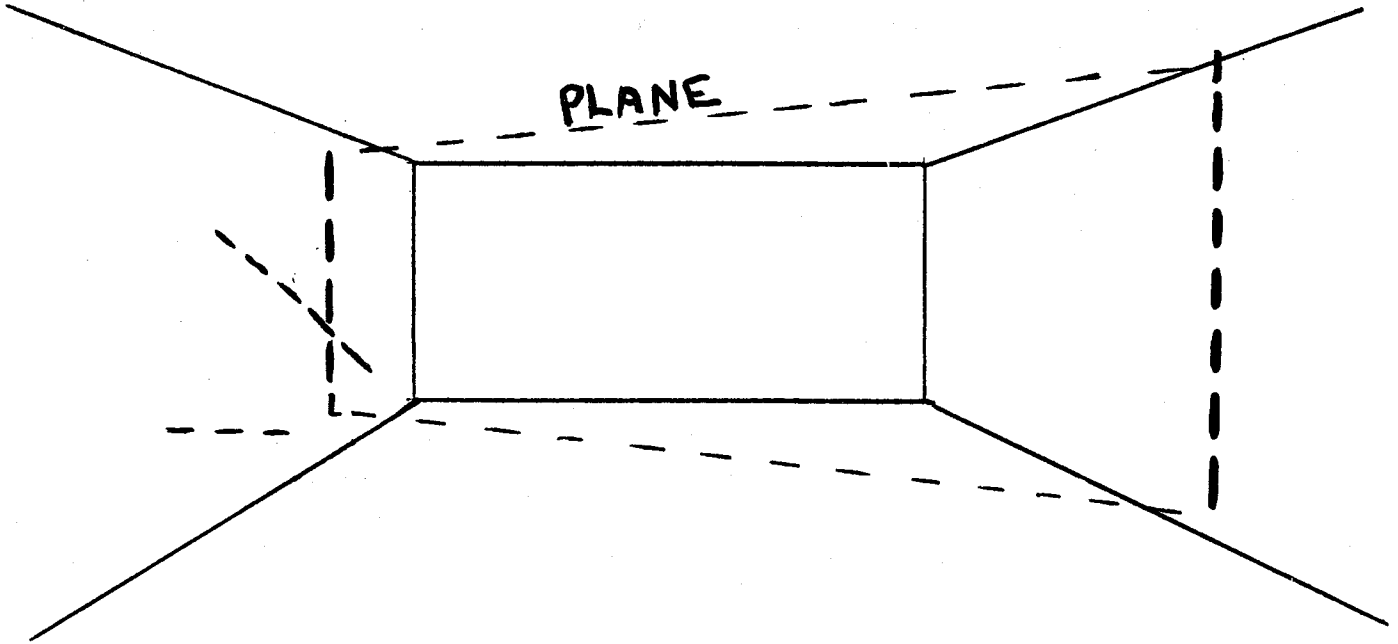

# LIMBS ON PLANE BETWEEN SIDE WALL & BACK CORNER

The following figures have limbs extending on the plane between the side wall and back corner wall.

On pages 105-144 Position Symbols, round symbols written below the five-lined staff, clarify the positions for the reader. The Position Symbols act as a double check on the stick figure and show the complete third dimension, adding 100% accuracy to all drawings.

Facing Front Wall

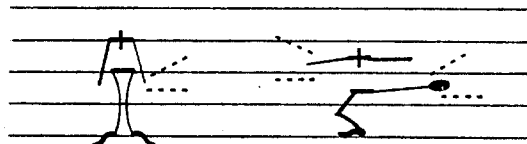

Facing Front Corner Walls

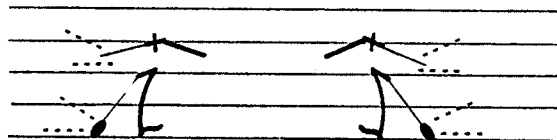

Facing Side Walls



Facing Back Corner Walls

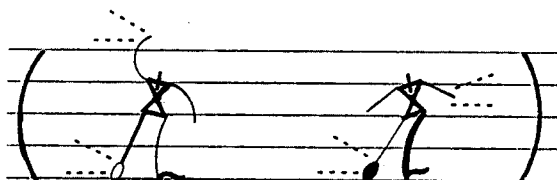

Facing Back Wall

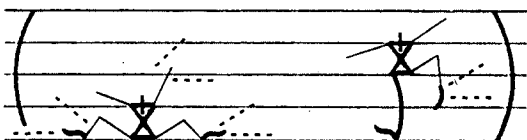

Facing Between Front Wall And Front Corner Walls

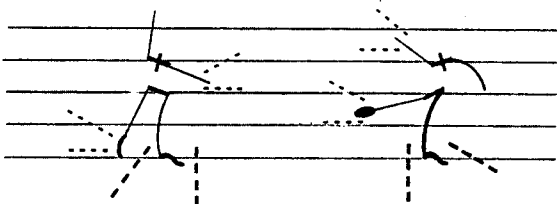

Facing Between Front Corner Walls And Side Walls

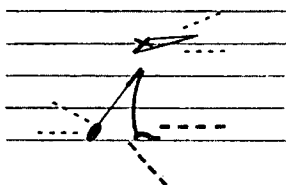

Facing Between Side Walls And Back Corner Walls



Facing Between Back Corner Walls And Back Wall

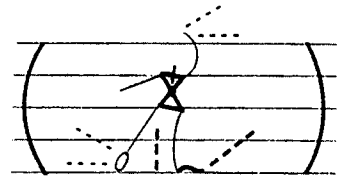

# BETWEEN BACK CORNER + BACK WALL

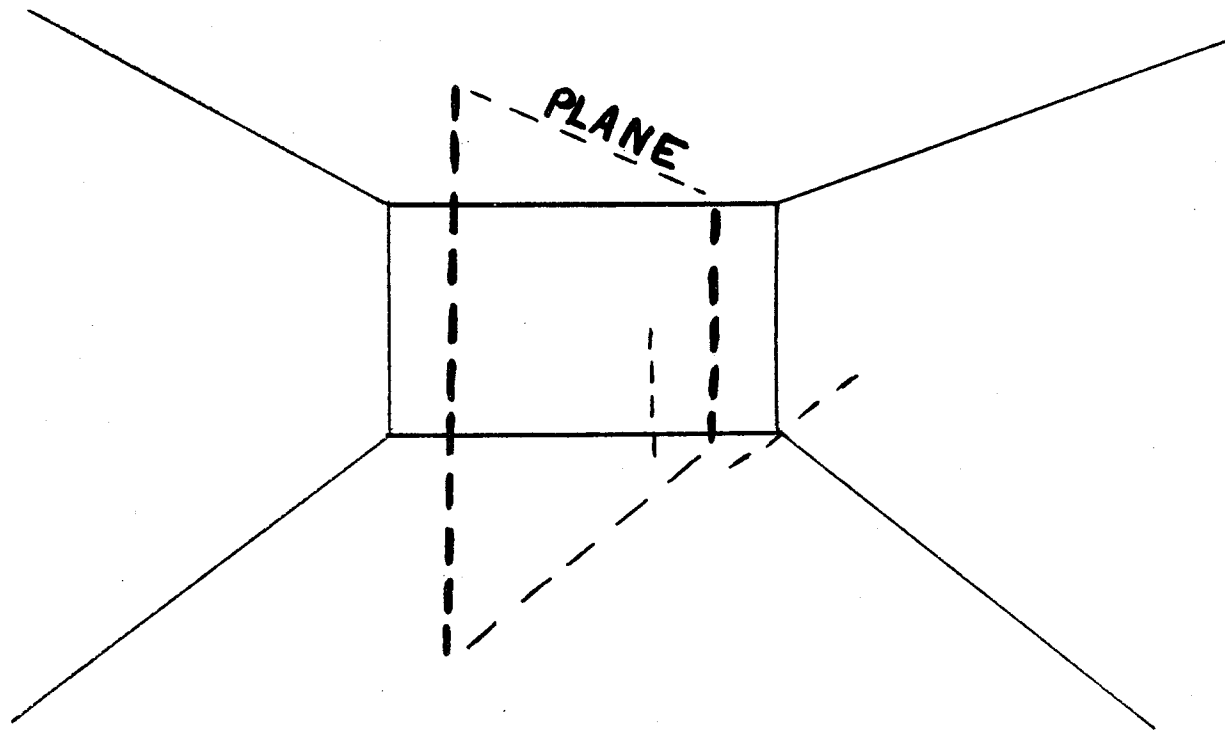
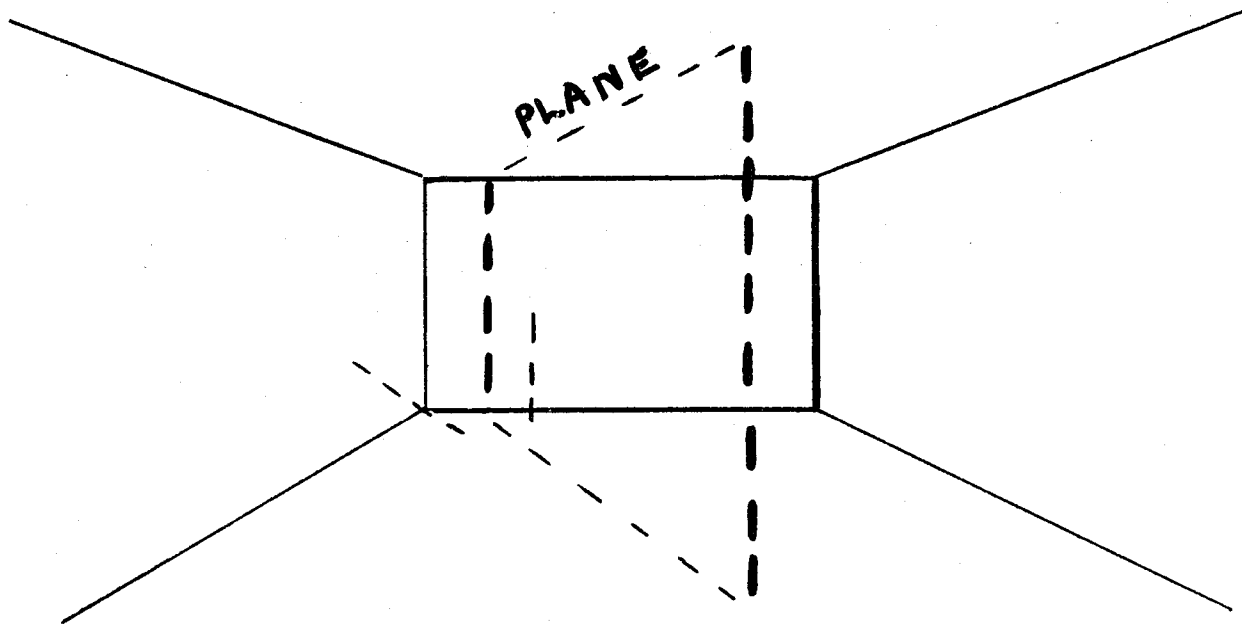

# LIMBS ON PLANE BETWEEN BACK CORNER + BACK WALL

The following figures have limbs extending on the plane between the back corner wall and the back wall.

On pages 105-144 Position Symbols, round symbols written below the five-lined staff, clarify the positions for the reader. The Position Symbols act as a double check on the stick figure and show the complete third dimension, adding 100% accuracy to all drawings.

Facing Front Wall

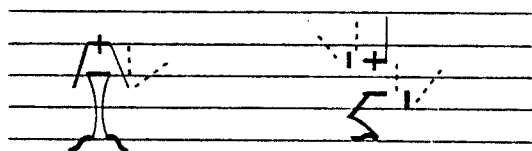

Facing Front Corner Walls

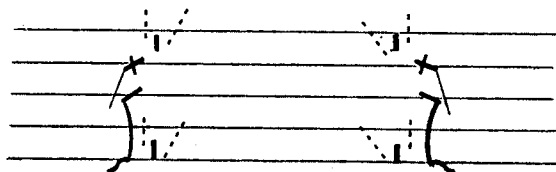

Facing Side Wall

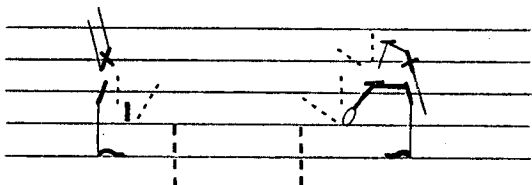

Facing Back Corner Walls

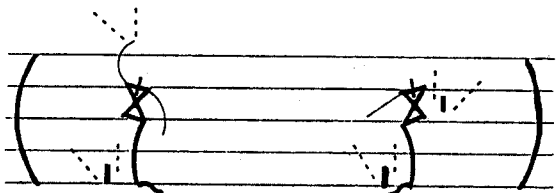

Facing Back Wall

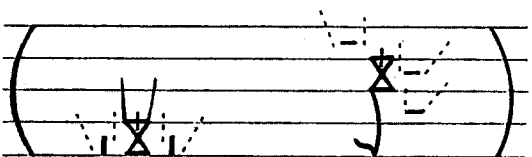

Facing Between Front Wall And Front Corner Walls

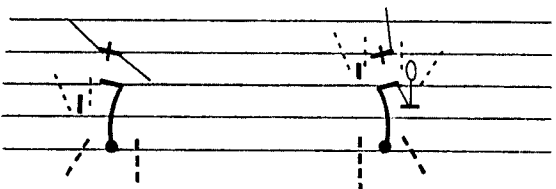

Facing Between Front Corner Walls And Side Walls

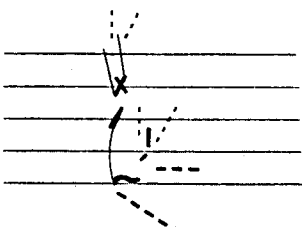

Facing Between Side Walls And Back Corner Walls

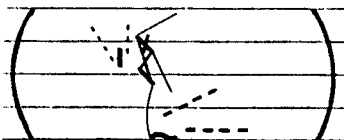

Facing Between Back Corner Walls And Back Wall

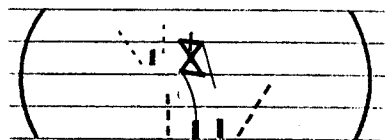

# THE PARTS OF THE BODY...

## THE FACE

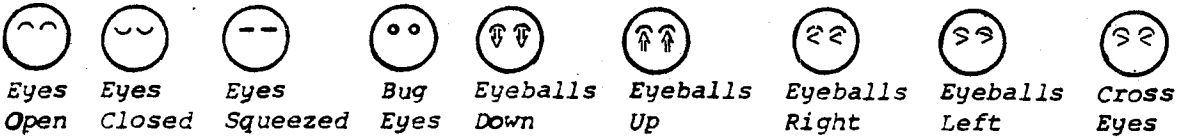
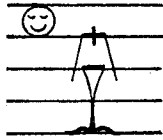

Eyes Open   Eyes Closed   Eyes Squeezed   Bug Eyes   Eyeballs Down   Eyeballs Up   Eyeballs Right   Eyeballs Left   Cross Eyes

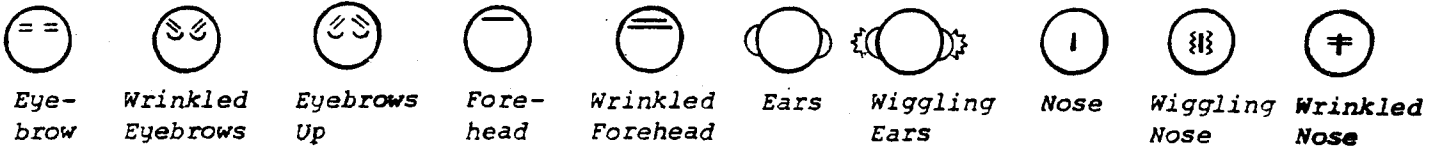

Eye-brow   Wrinkled Eyebrows   Eyebrows Up   Fore-head   Wrinkled Forehead   Ears   Wiggling Ears   Nose   Wiggling Nose   Wrinkled Nose

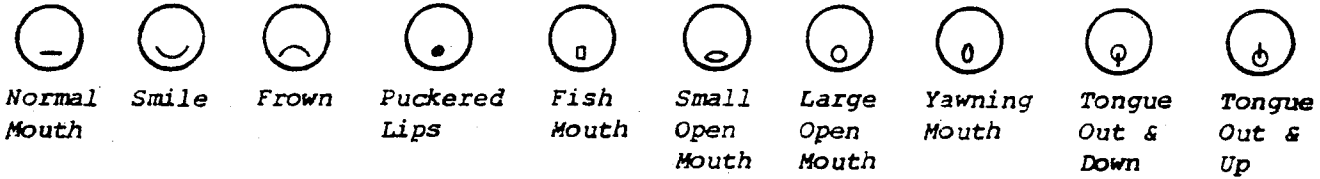

Normal Mouth   Smile   Frown   Puckered Lips   Fish Mouth   Small Open Mouth   Large Open Mouth   Yawning Mouth   Tongue Out & Down   Tongue Out & Up

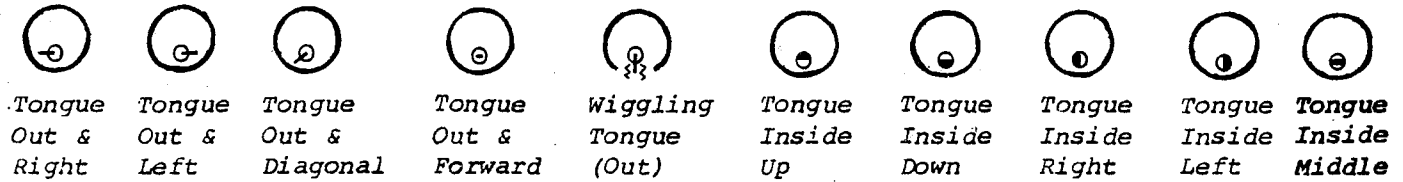

Tongue Out & Right   Tongue Out & Left   Tongue Out & Diagonal   Tongue Out & Forward   Wiggling Tongue (Out)   Tongue Inside Up   Tongue Inside Down   Tongue Inside Right   Tongue Inside Left   Tongue Inside Middle

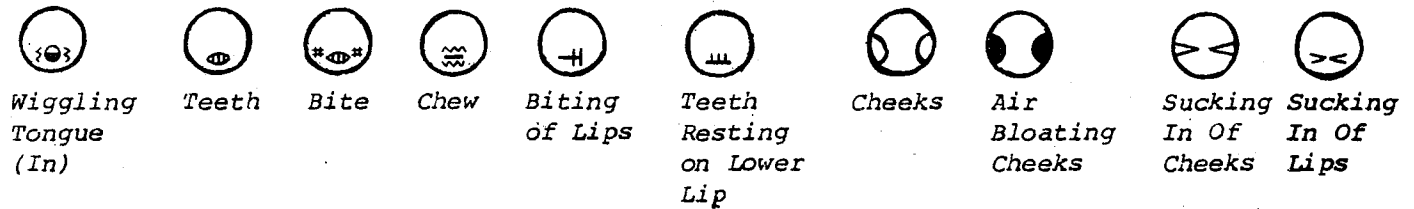

Wiggling Tongue (In)   Teeth   Bite   Chew   Biting of Lips   Teeth Resting on Lower Lip   Cheeks   Air Bloating Cheeks   Sucking In Of Cheeks   Sucking In Of Lips

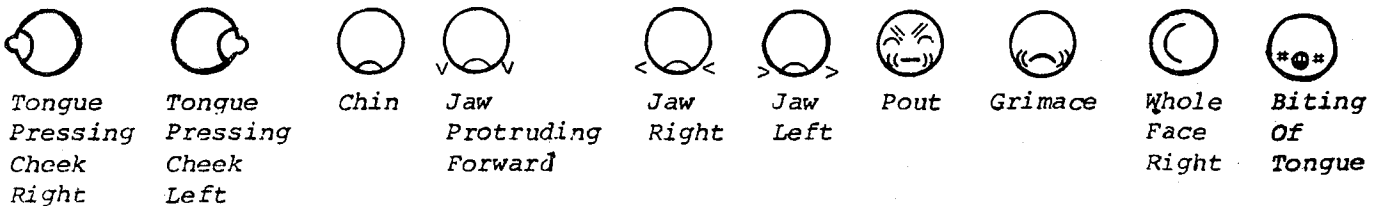

Tongue Pressing Cheek Right   Tongue Pressing Cheek Left   Chin   Jaw Protruding Forward   Jaw Protruding Right   Jaw Protruding Left   Pout   Grimace   Whole Face Right   Biting Of Tongue



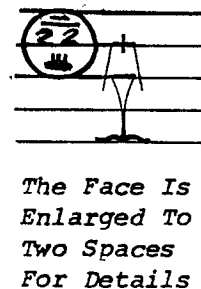
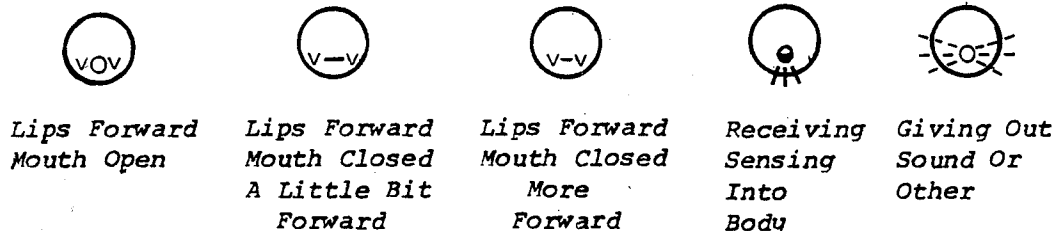
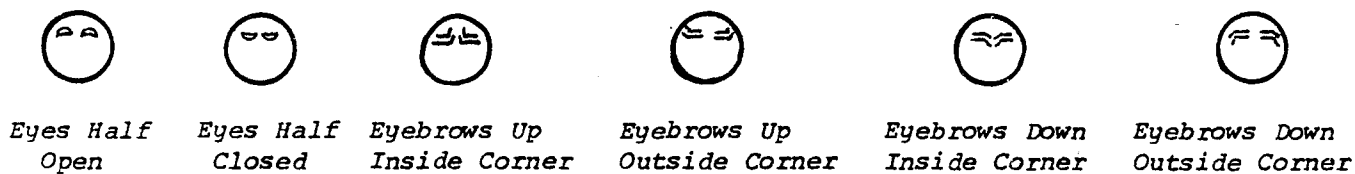
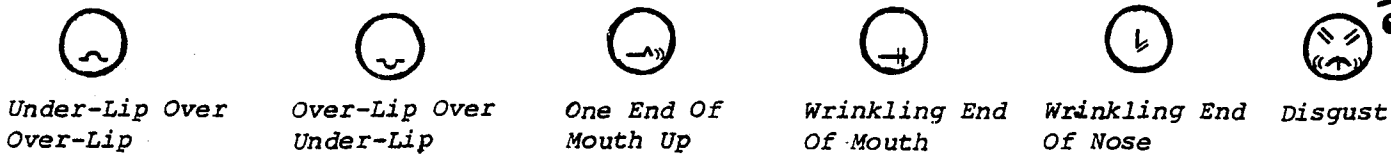
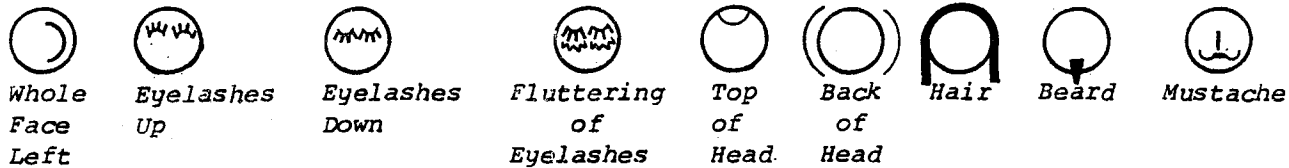

SENSE LINES

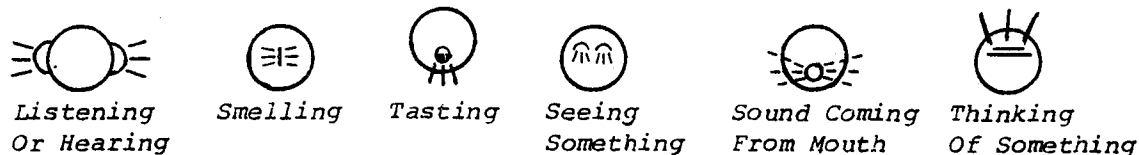

EMOTIONS

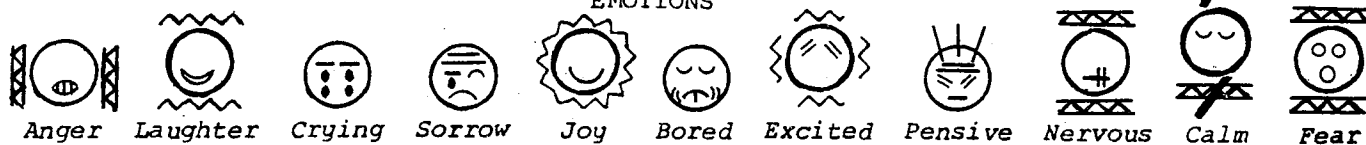

DETAILED LIP AND MOUTH NOTATION

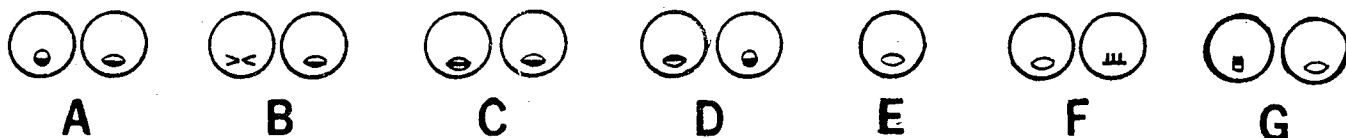

# THE NECK

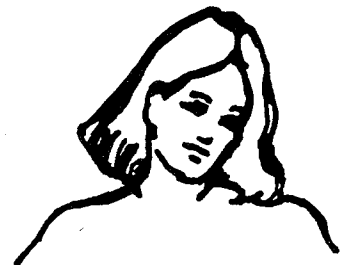
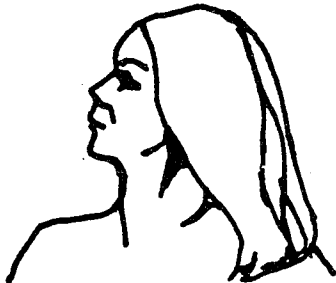
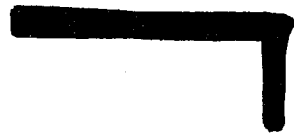
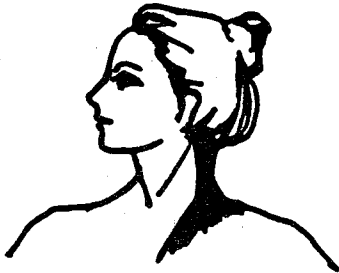
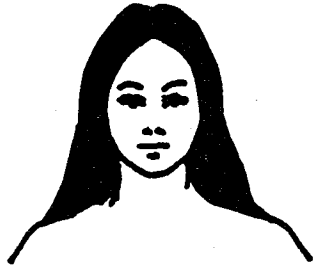

# THE SHOULDERS

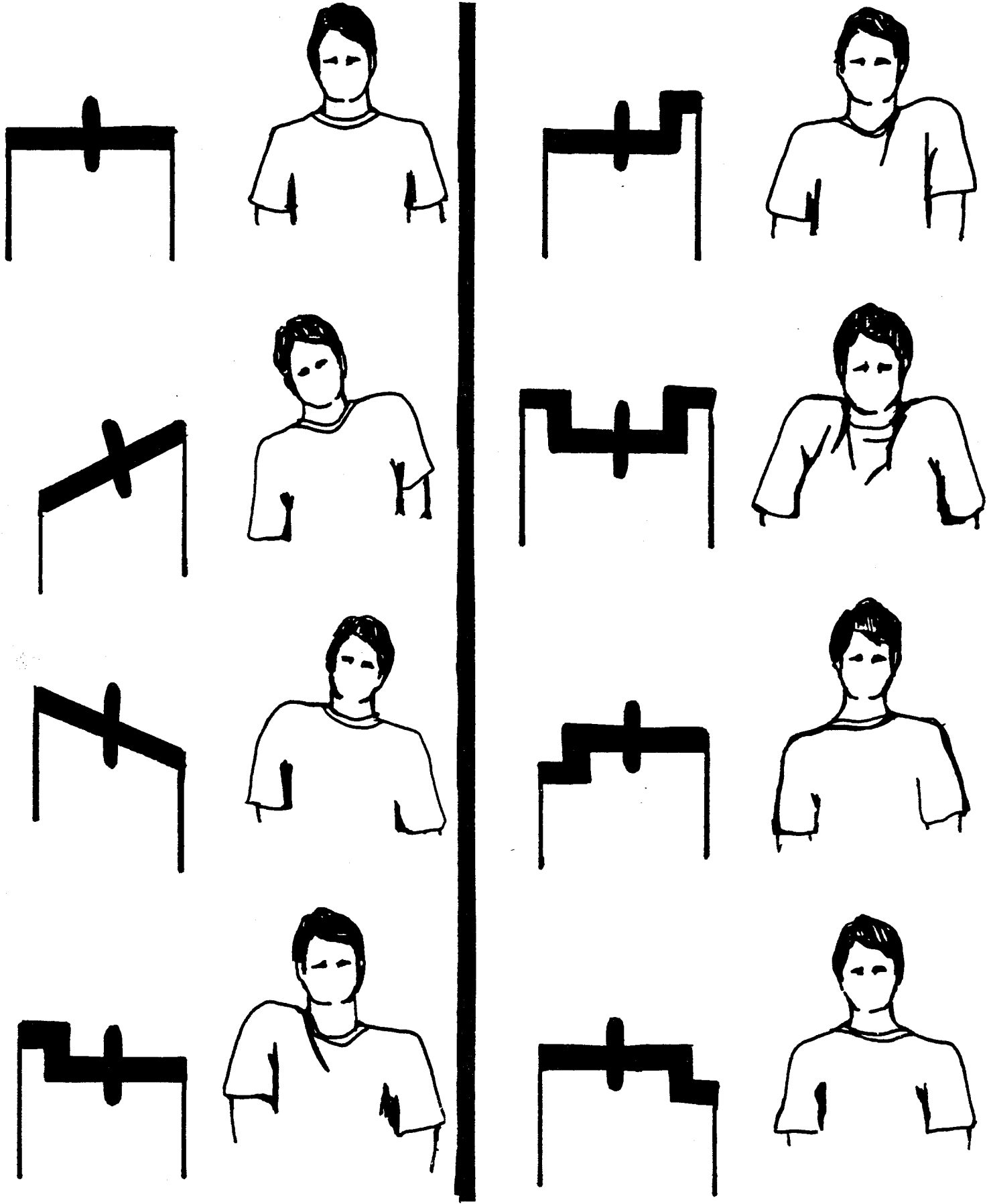

# THE SHOULDERS

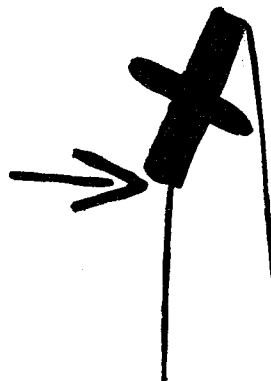
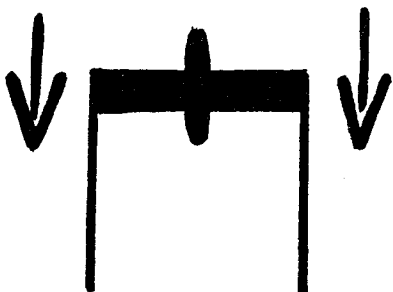
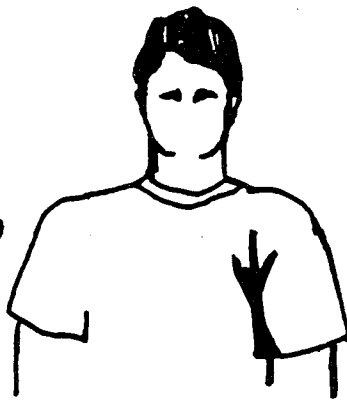
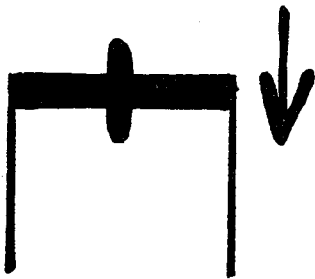
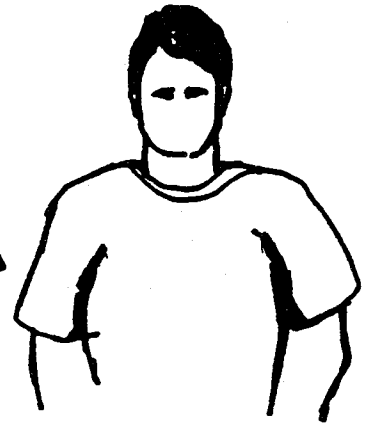
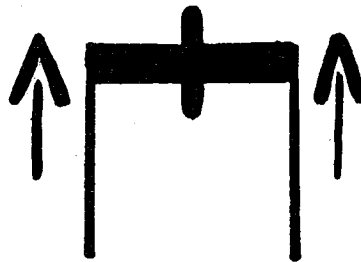
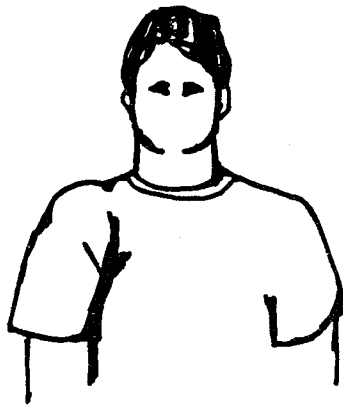
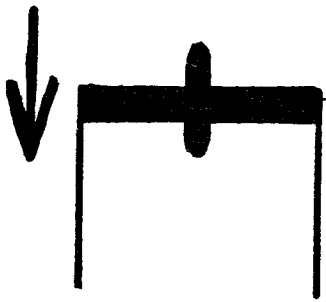
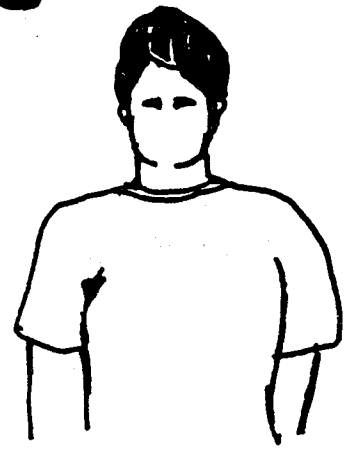
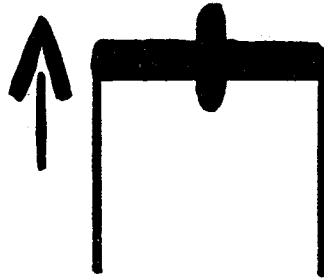
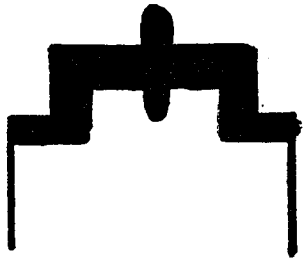

# MOVEMENT WHILE REMAINING ON CENTER DOT

Diagonal Plane

Back Corner



Sagittal Plane

Back

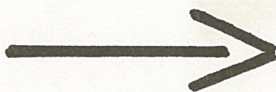

Diagonal Plane

Back Corner



Frontal Plane

Side Wall



Frontal Plane

Down

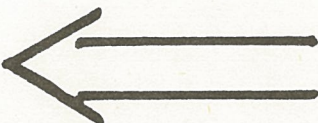

Frontal Plane

Up

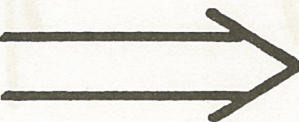

Frontal Plane

Side Wall



Diagonal Plane

Front Corner



Diagonal Plane

Front Corner



Forward

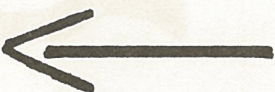

MOVEMENT THAT DOES NOT TRAVEL  
Movements done while remaining in one place are notated with arrows. These small movements do not move the body from one place to another. They include positions of the face, shoulders, hips, wrist and ankle flexing, twisting and bending of the torso, and small movements of the arms, legs and spine.

Copyright © 1979 by Valerie J. Sutton

ALL RIGHTS RESERVED

Pan American And Universal Copyrights Secured

Diagonal Plane

# THE HIPS

Left  
Hip  
Up



Left  
Hip  
Down

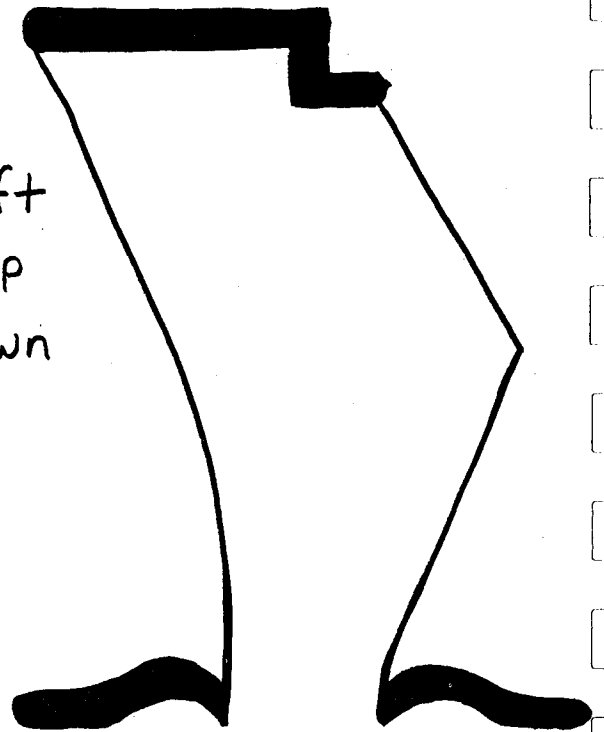

Both  
Hips  
Pressed  
Forward

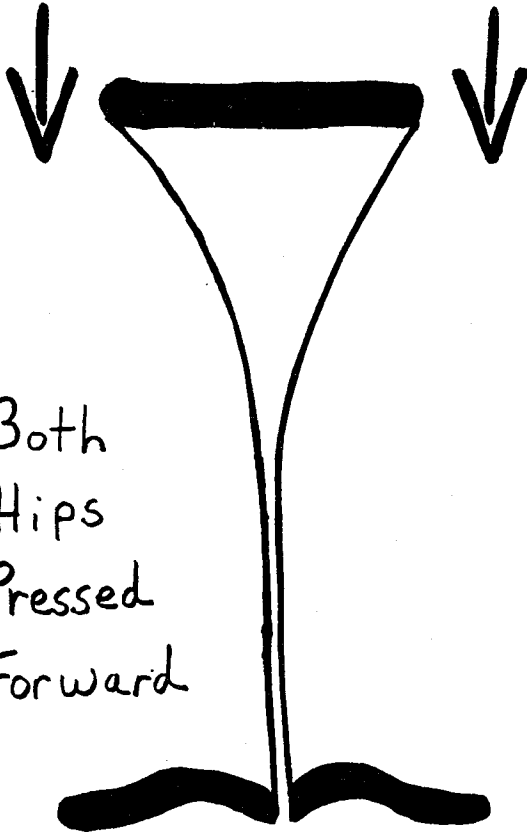

Both  
Hips  
Pressed  
To The  
Back

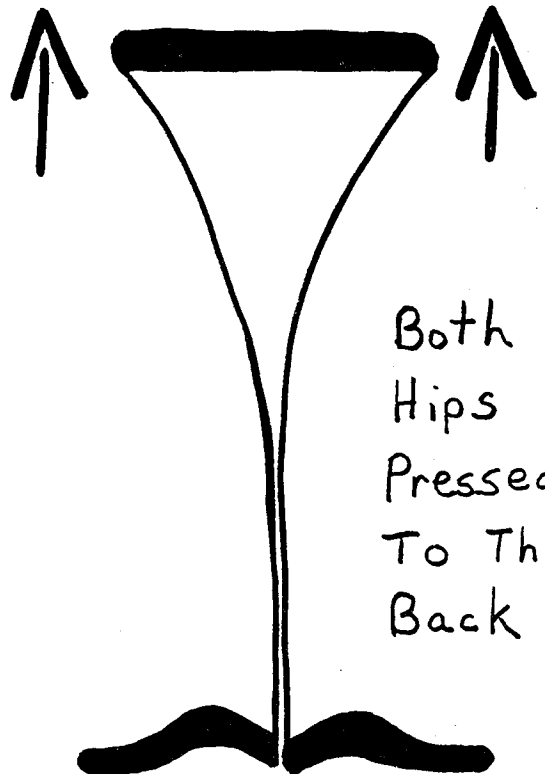

# HIP AND SHOULDER ARROWS PUSH FORWARD AND BACK

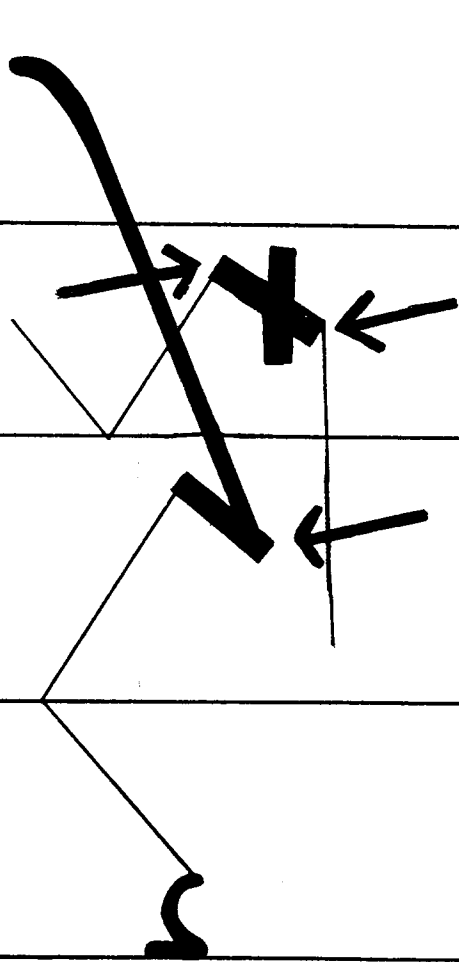

# THE HANDS AND FINGERS

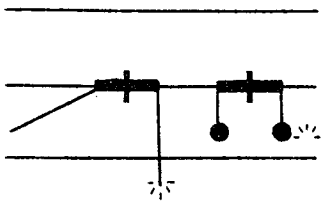

*The Neutral Hand  
(Relaxed Without Set Shape)*

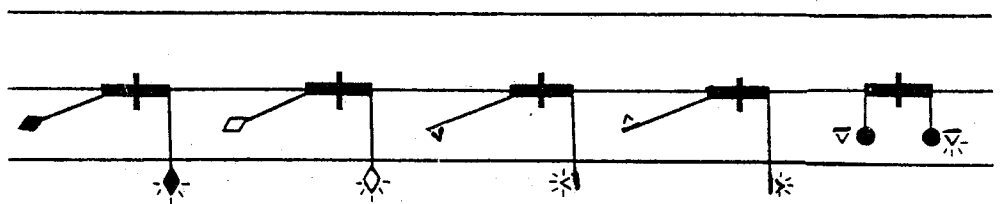

*The Flat Hand  
(Fingers Stretched, Hand Flat)*

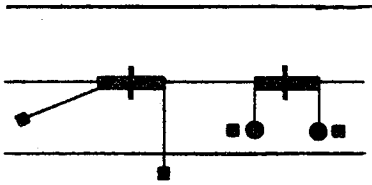

*The Closed Fist  
(Fingers Touch Palm of Hand)*

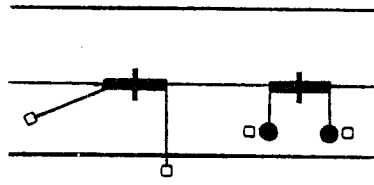

*The Open Fist  
(Fingertips Touch Each Other)*

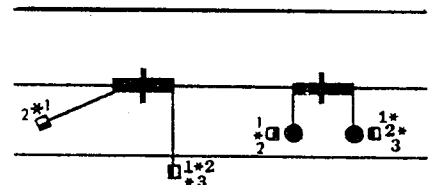

*The Open/Closed Fist  
(Some Fingertips Touch Palm,  
Some Fingertips Touch Each Other)*

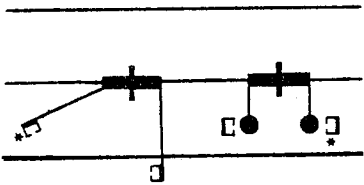

*The Claw Hand  
(Fingers Bent At  
First Two Joints)*

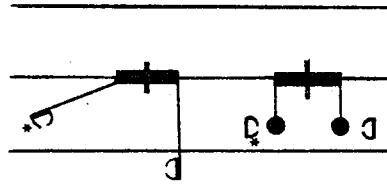

*The Cupped Hand  
(Fingers Curved In Shape of C)*

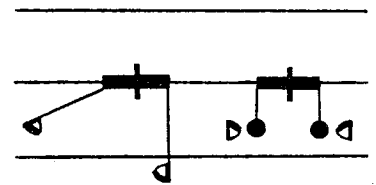

*The Curved-Lotus Hand  
(Fingertips Touching  
In Elongated Curve)*

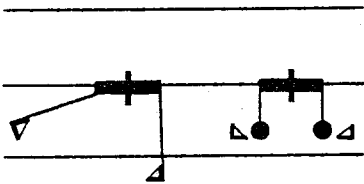

*The Straight-Lotus Hand  
(Fingers Straight,  
Thumb Touching Under)*

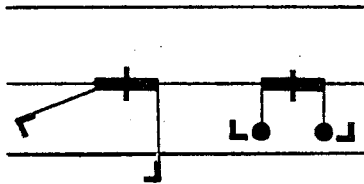

*The Half-Lotus Hand  
(Fingers Straight,  
Thumb To The Side)*

**HAND SHAPES SEEN FROM ALL VIEWPOINTS**

1. The Neutral Hand
2. The Flat Hand
3. The Closed Fist

**HAND SHAPES SEEN ONLY FROM THE SIDE**

1. The Open Fist
2. The Open/Closed Fist
3. The Claw Hand
4. The Cupped Hand
5. The Curved-Lotus Hand
6. The Straight-Lotus Hand
7. The Half-Lotus Hand

**THE FINGERS**

**Letters For Joints of Fingers**

- A = Tip of Finger
- B = Pad of Finger
- C = First Joint of Finger
- D = Between First and Second Joints
- E = Second Joint of Finger
- F = Between Second and Third Joints
- G = Third Joint of Finger
- H = Between Third Joint & Knuckle
- I = Knuckle

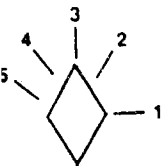

**Numbers For Fingers**

- 1 = Thumb
- 2 = Index Finger
- 3 = Middle Finger
- 4 = Ring Finger
- 5 = Baby Finger

**IMPORTANT RULE**

The fingers that have the fingertips closest to the palm of the hand determine the shape of the hand symbol. If the fingers closest to the palm of the hand are in the shape of a fist - then write a square for the fist. If the lowest fingers are in the shape of a claw, then write a claw shape. This is called the Base Handshape. If other fingers stick out from the Base Handshape, then write them with little lines protruding from the Base.



# THE FLAT HAND

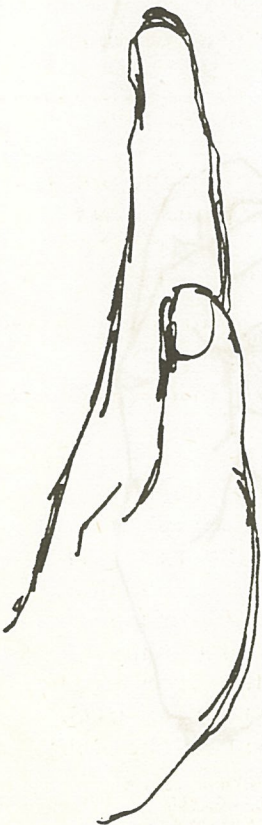
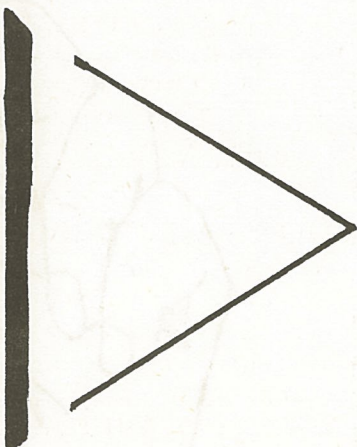
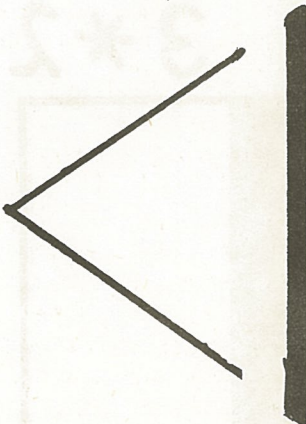
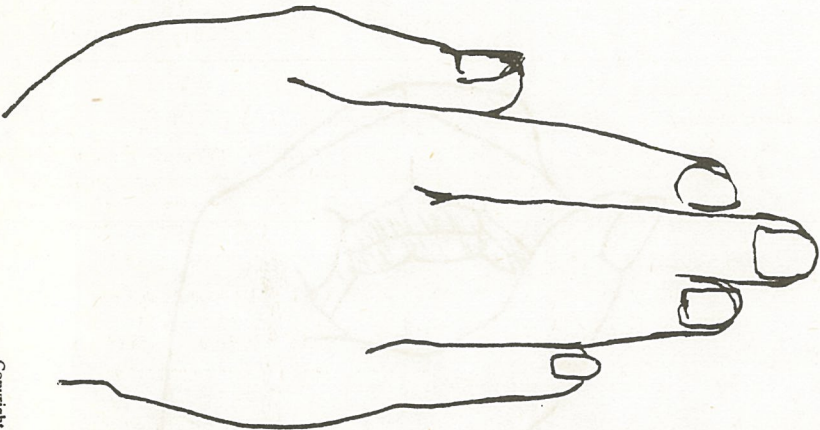
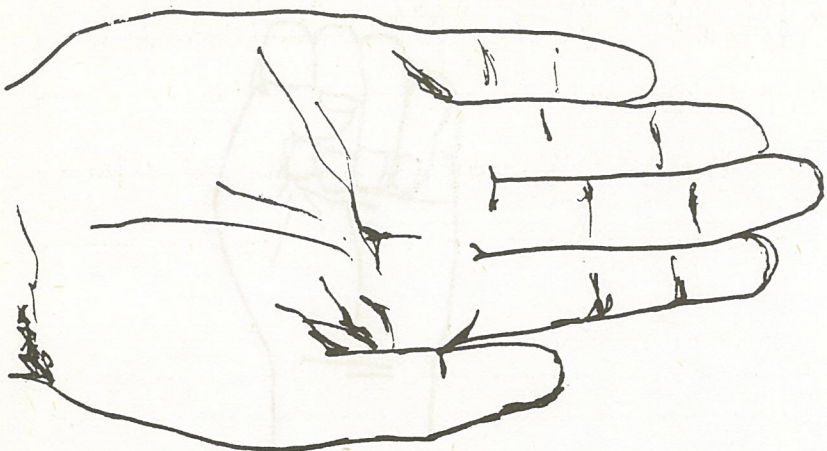
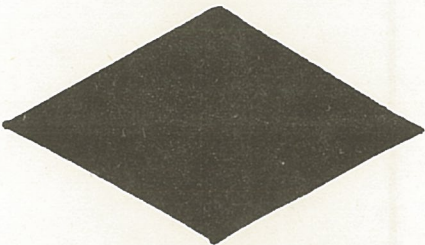
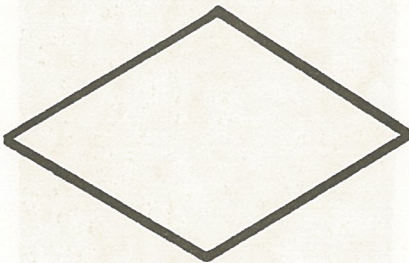

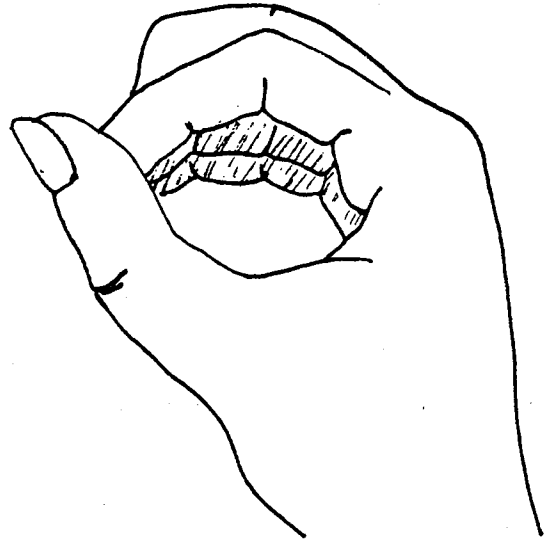
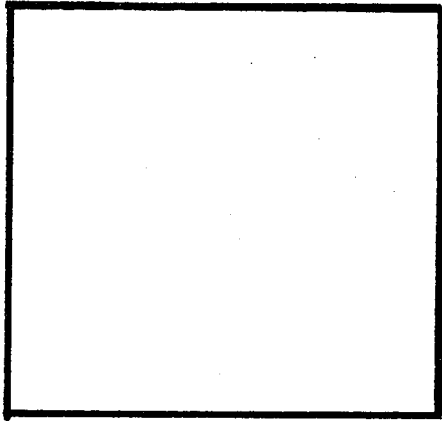

3 \* 2 \* 1

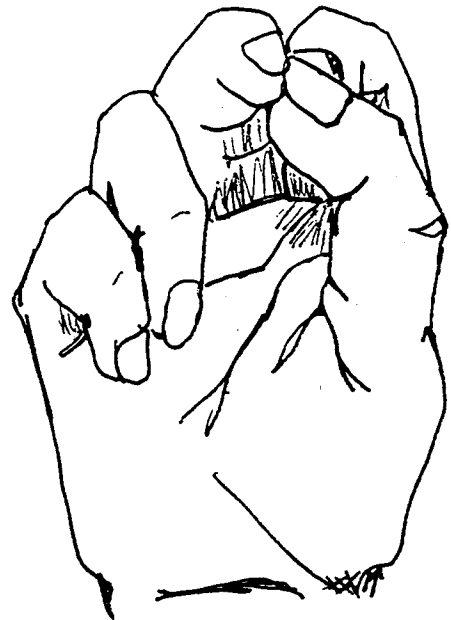
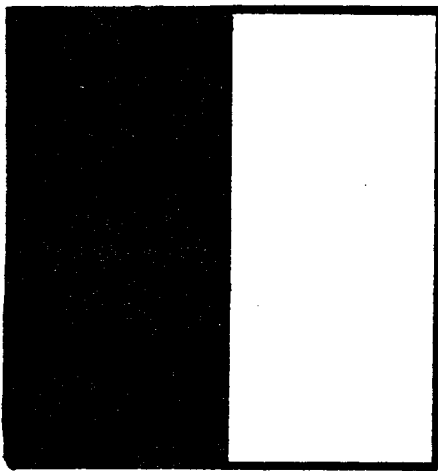

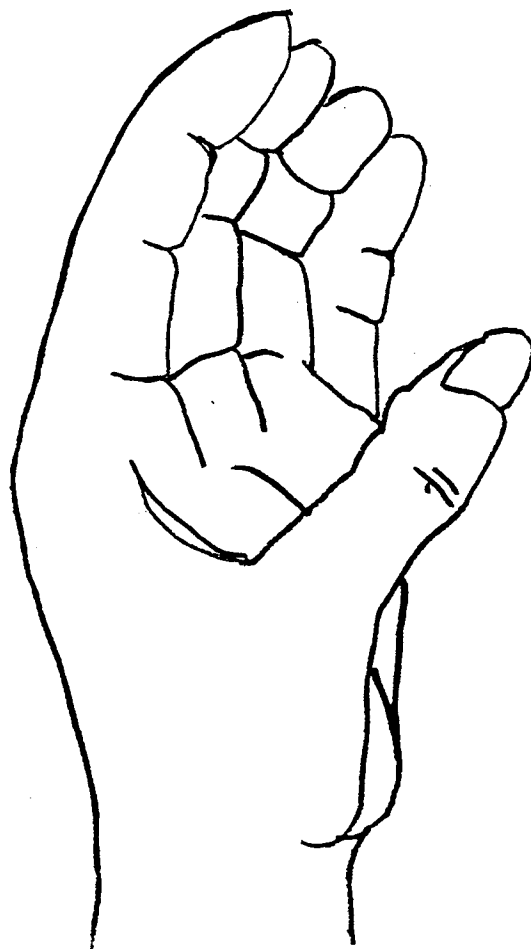
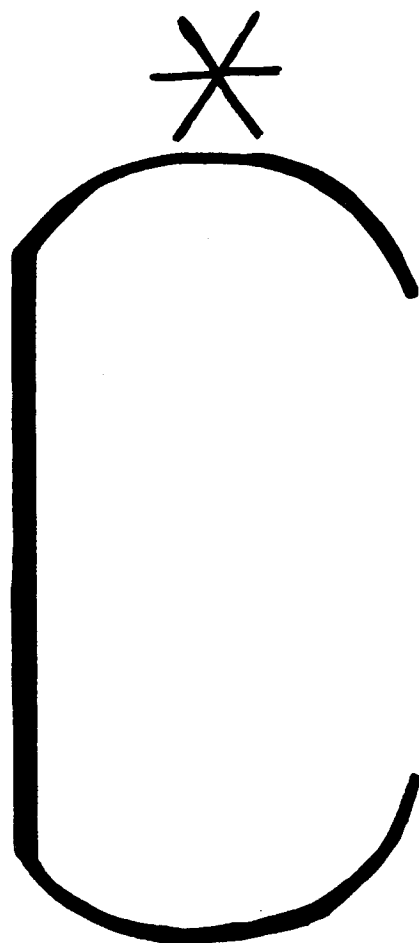
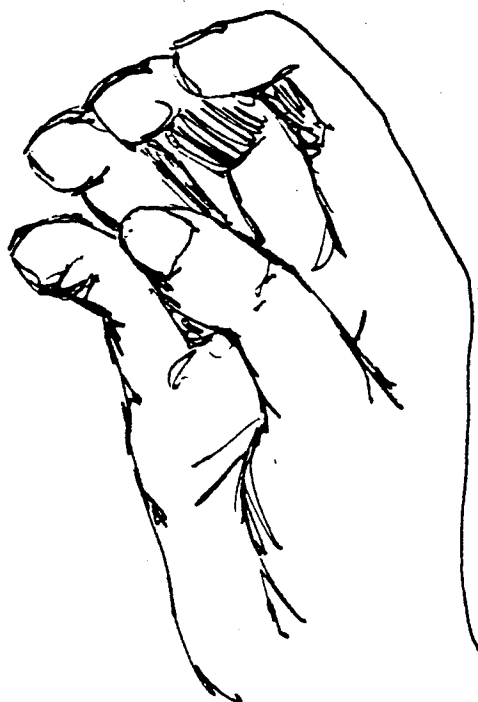
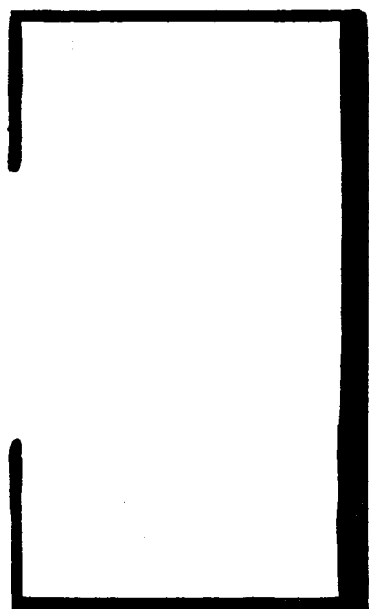

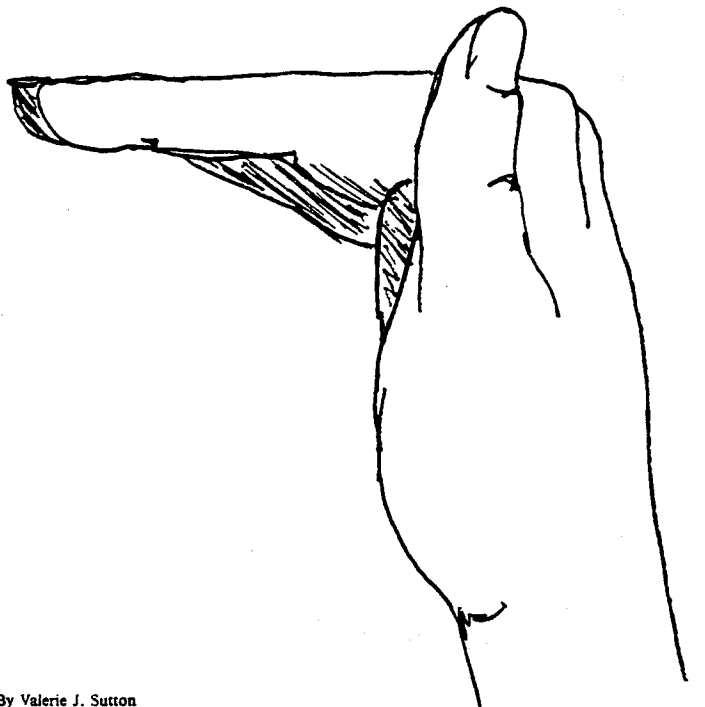
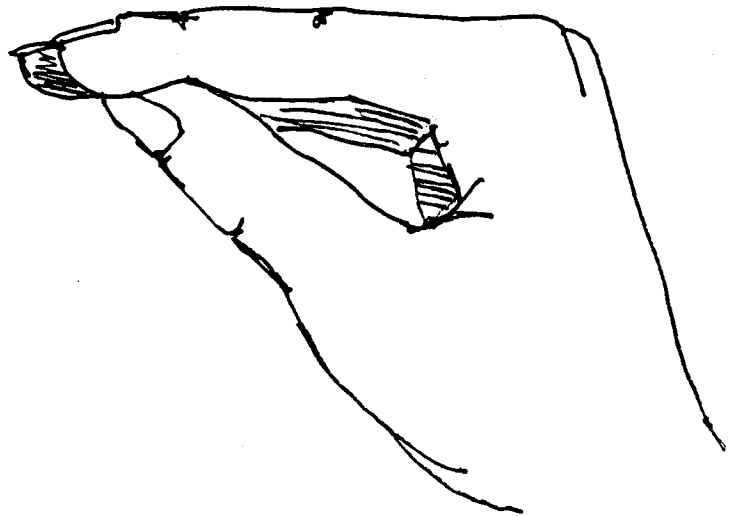
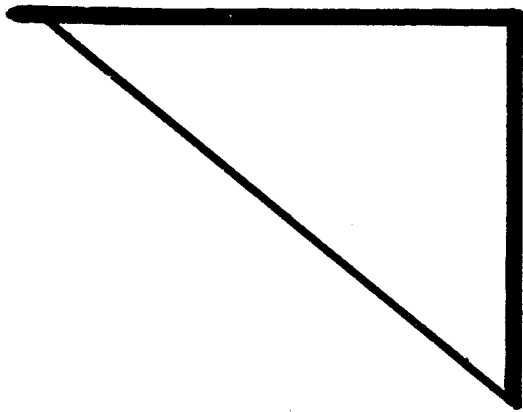
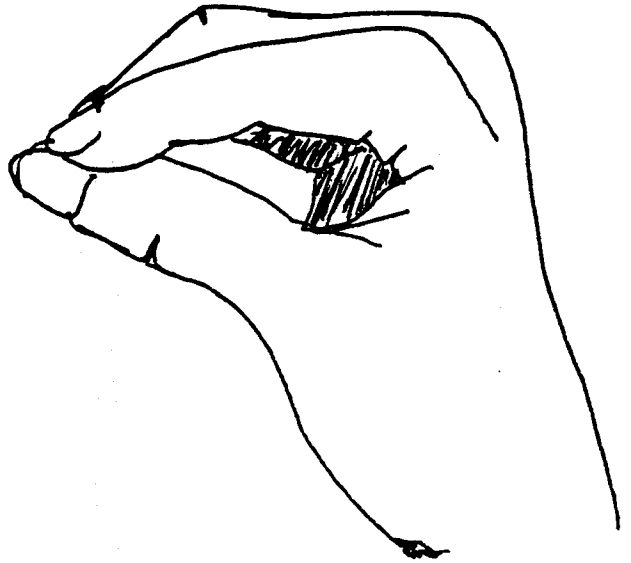
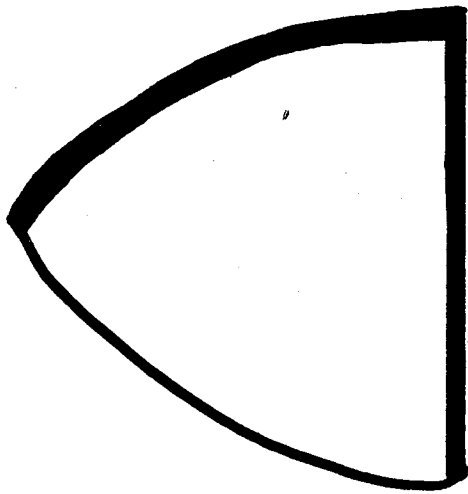

# THE CURVED-BACK HAND

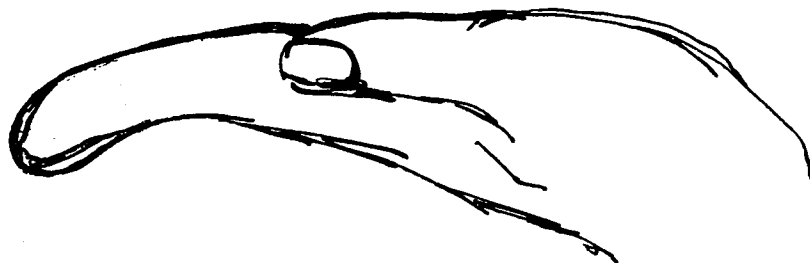
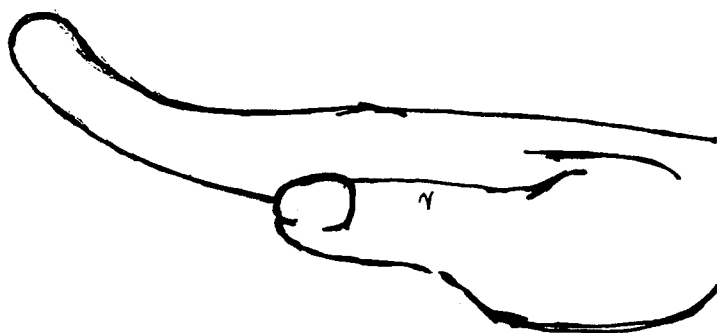

THE CLASSICAL BALLET HAND

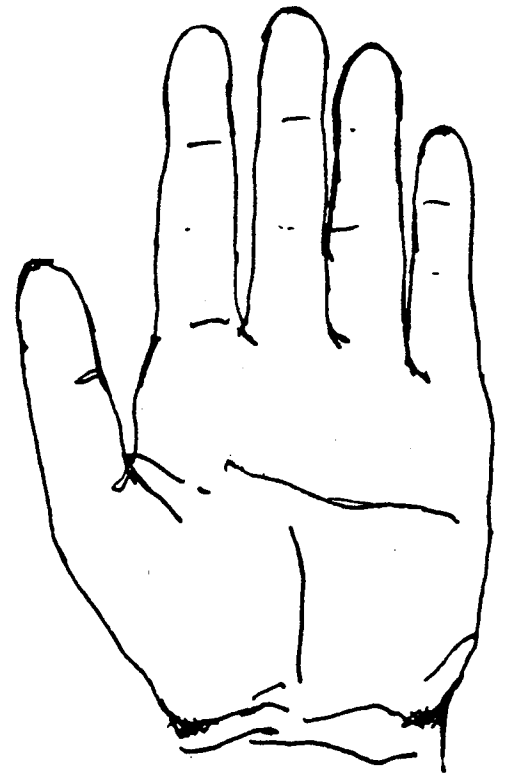
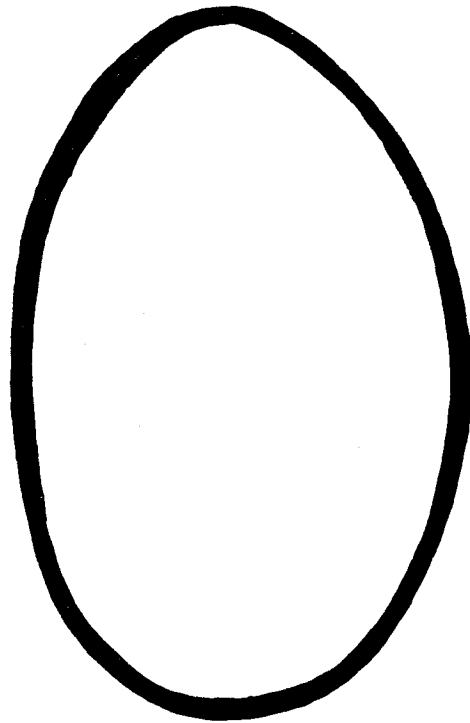
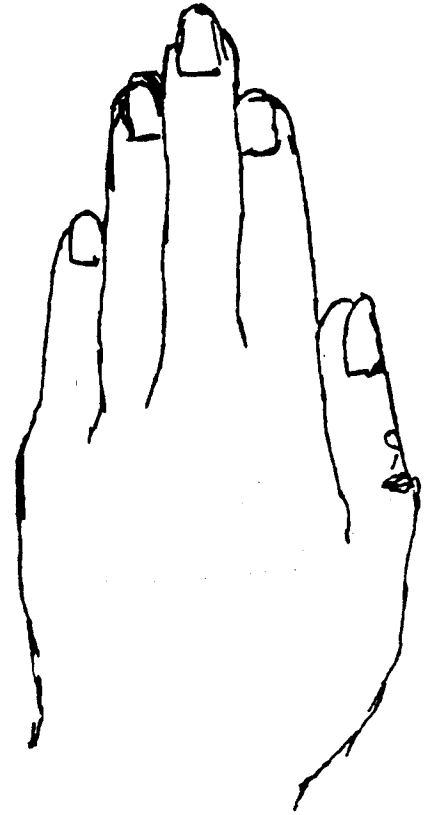
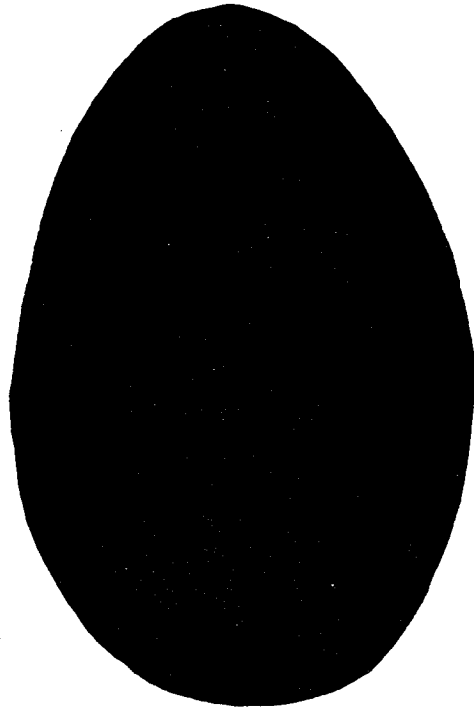



THE  
C  
L  
A  
S  
S  
I  
C  
A  
L

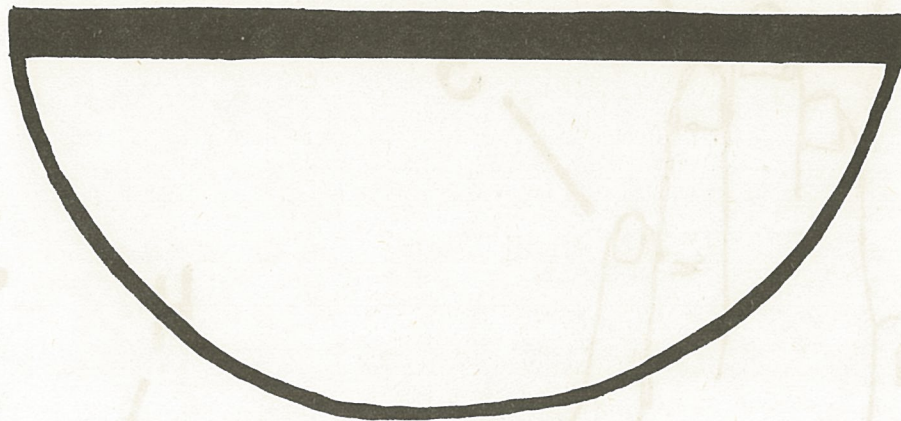
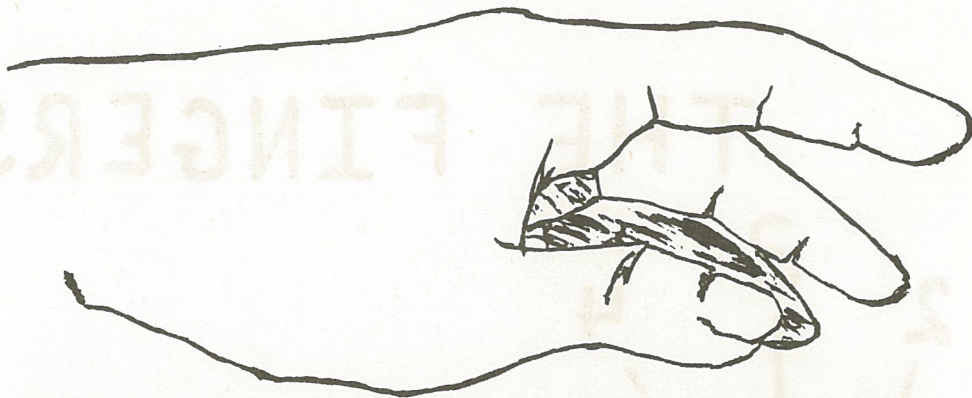

B  
A  
L  
L  
E  
T  
H  
A  
N  
D

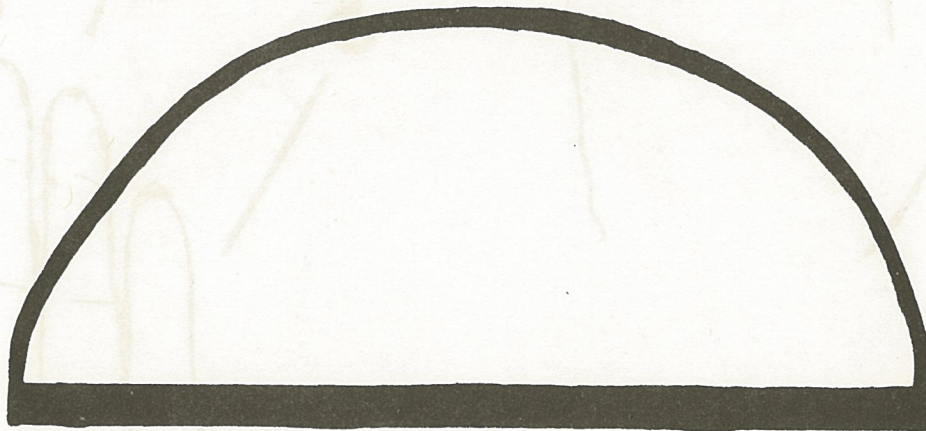
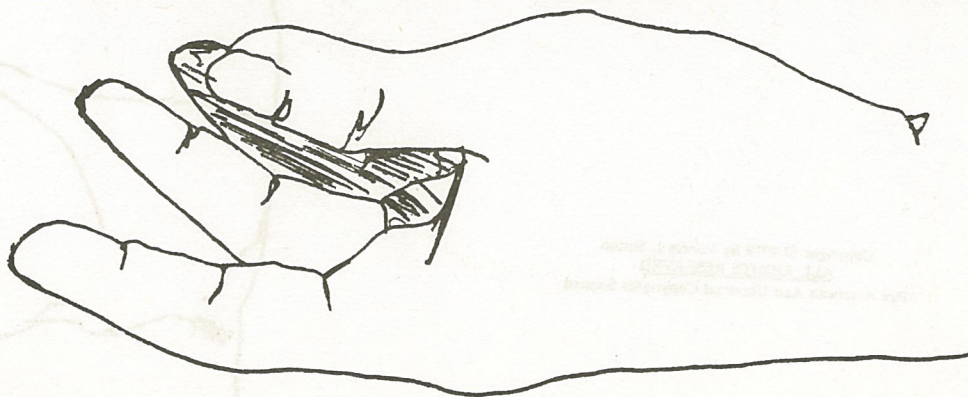

# THE FINGERS

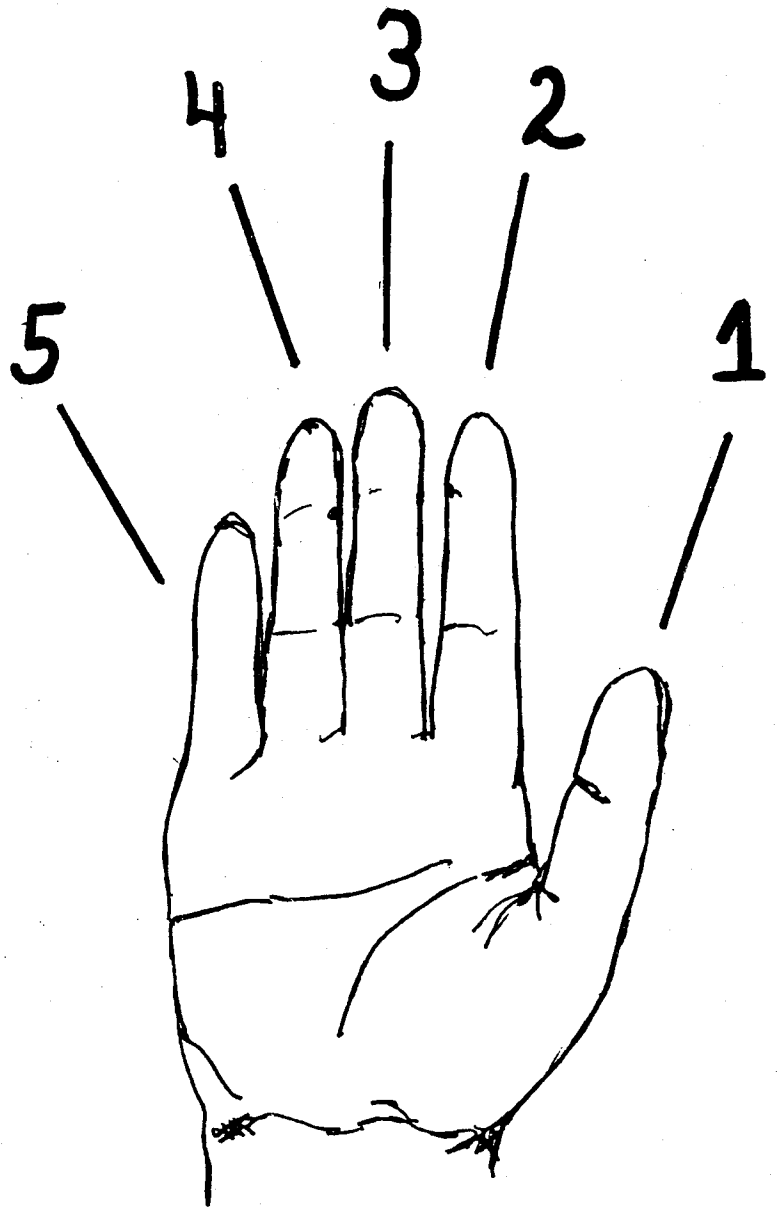
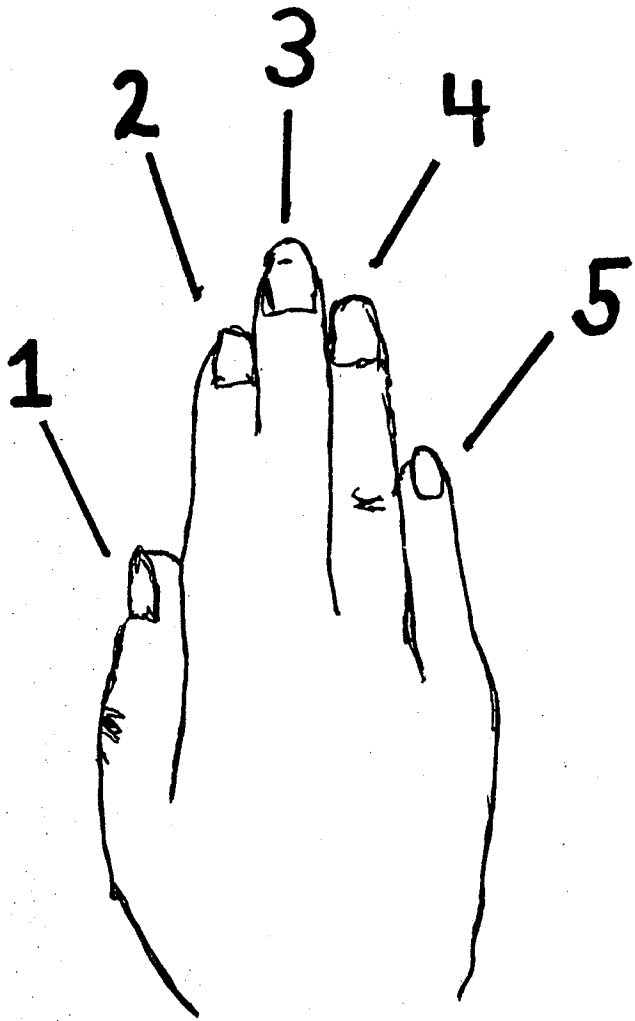



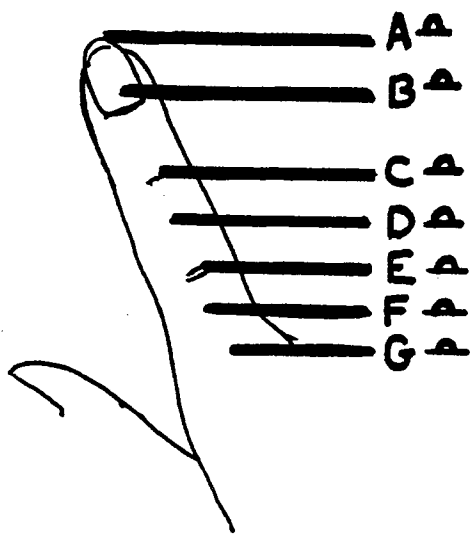

Over Part Of Finger

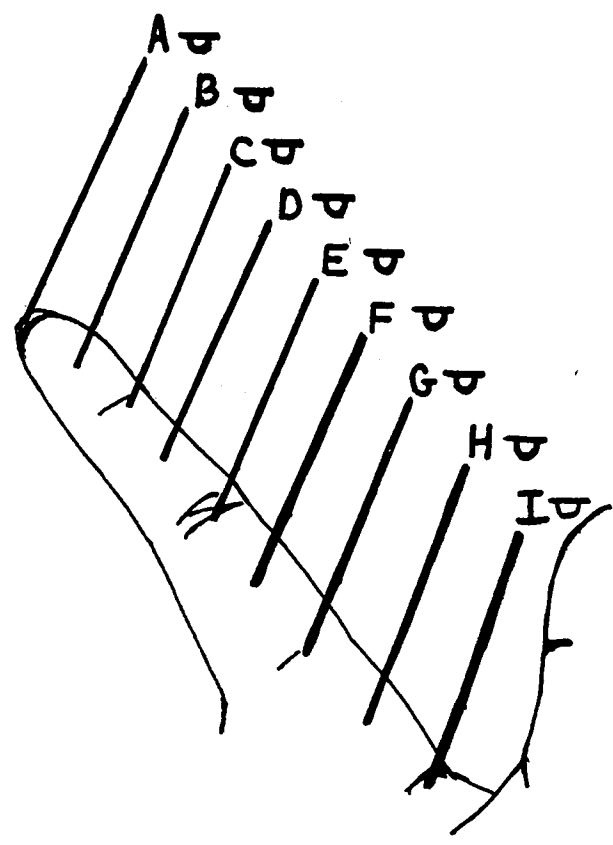

Under Part Of Finger

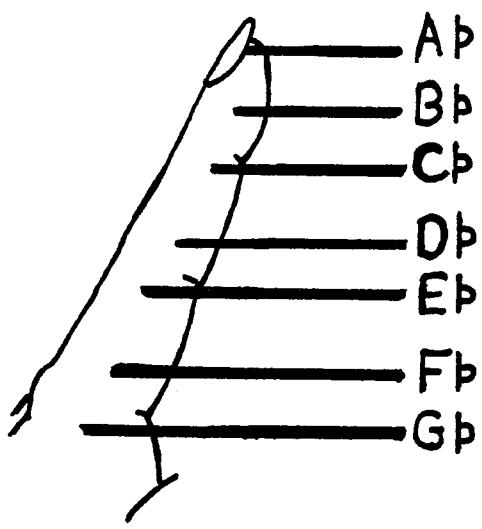

Inside Of Finger

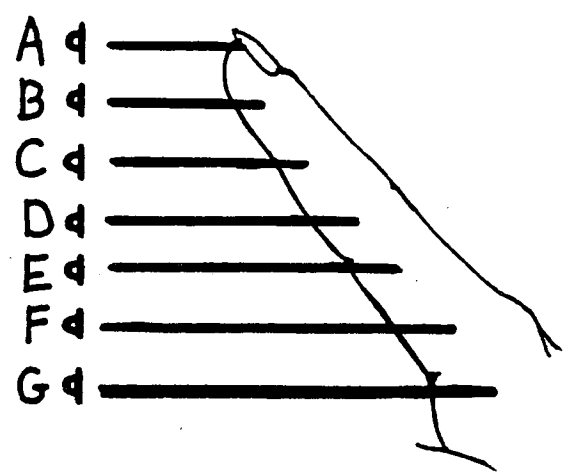

OVER

Over Part (Top) Of Hand

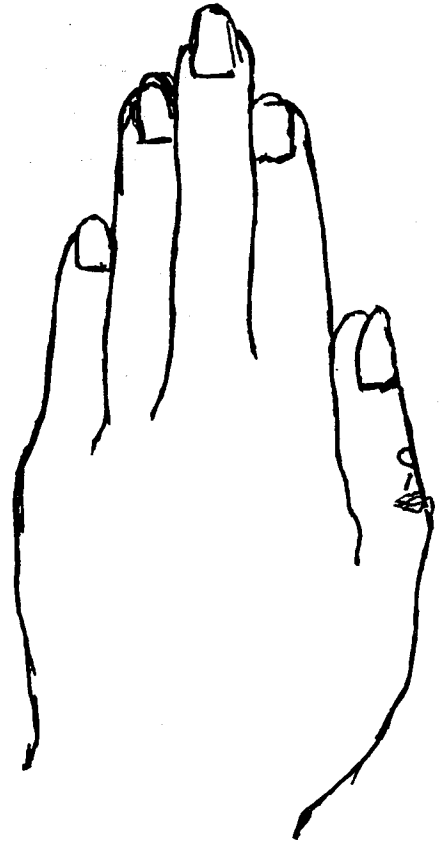
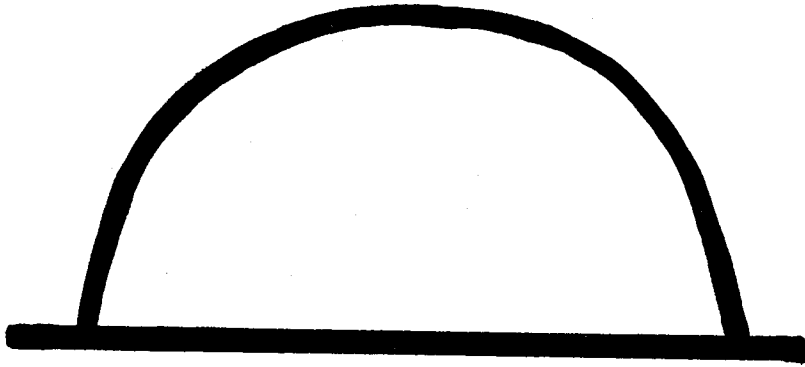

UNDER

Under Part (Palm) Of Hand

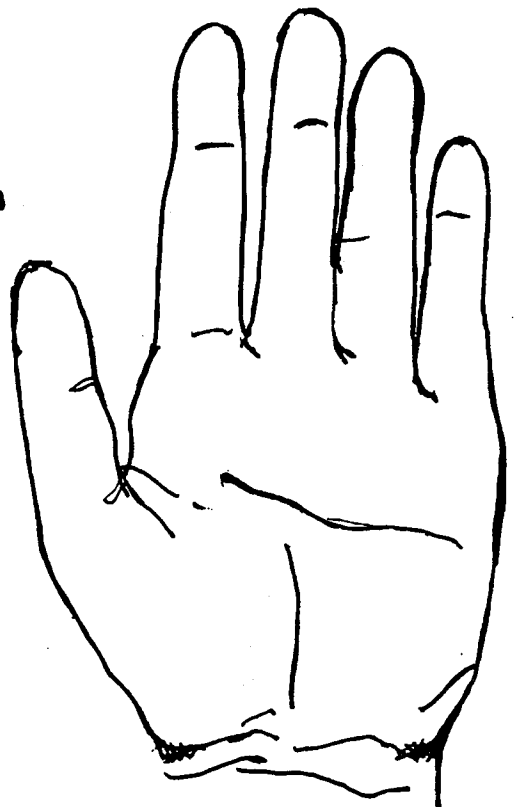
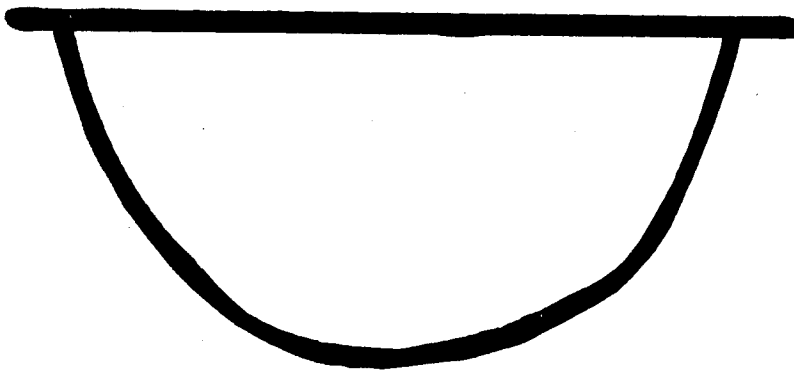

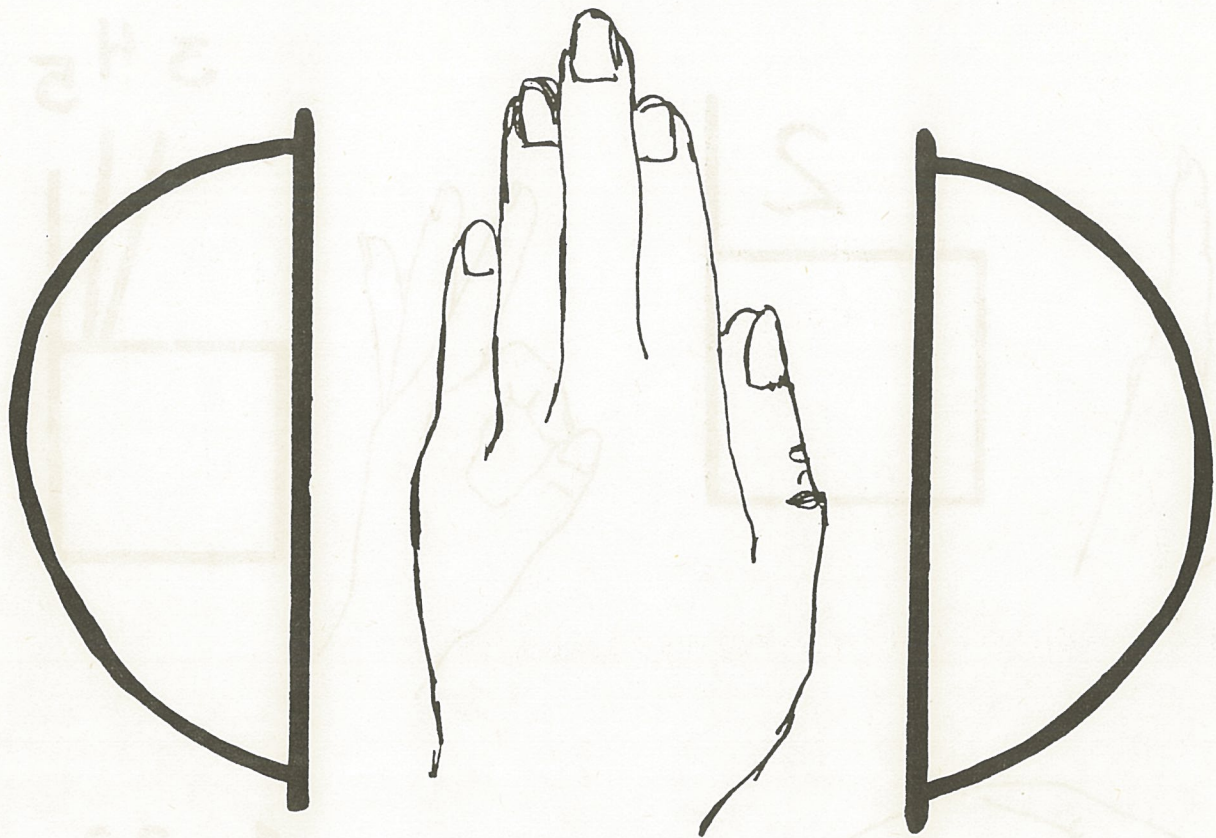

ON THE SIDE OF  
The Side Of The Hand

ON THE SIDE OF  
The Side Of The Hand

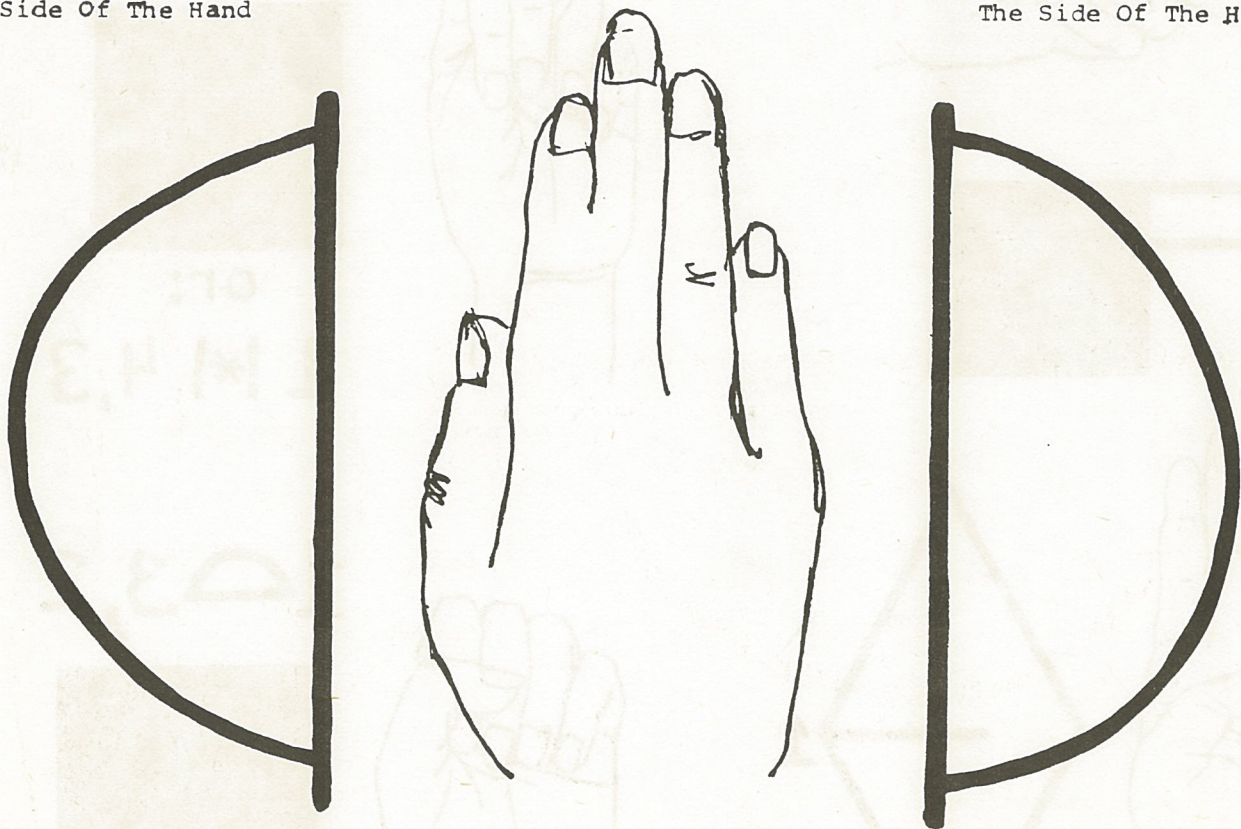

Copyright © 1979 By Valerie J. Sutton  
ALL RIGHTS RESERVED  
Pan American And Universal Copyrights Secured

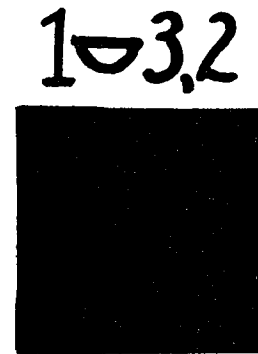
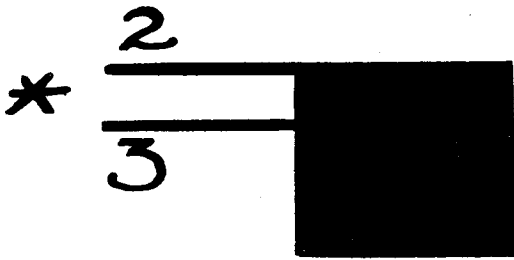
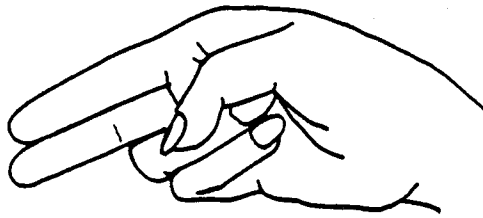
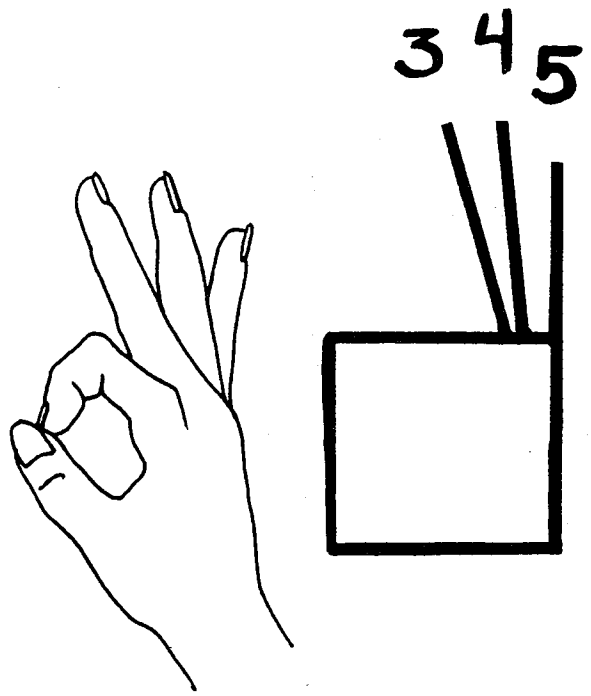
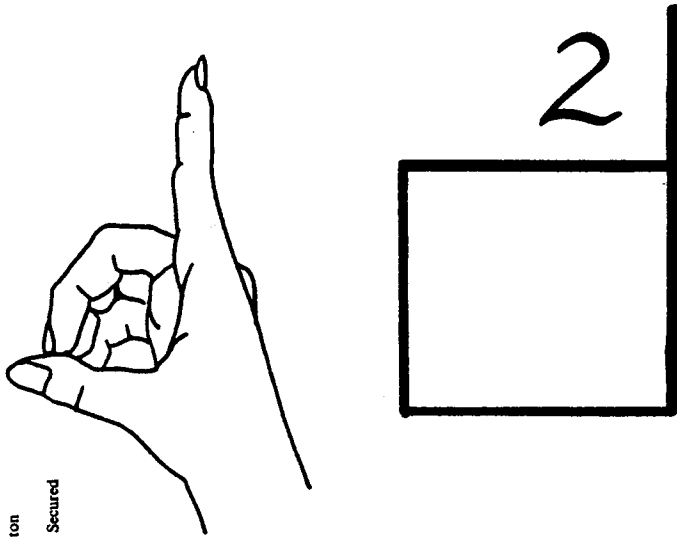

or:  
1 | \* | 4,3

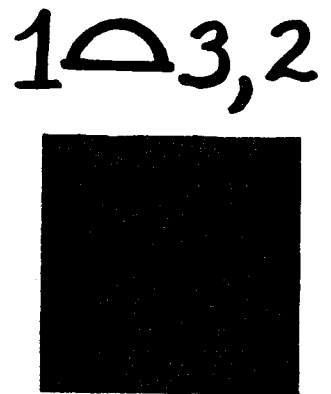
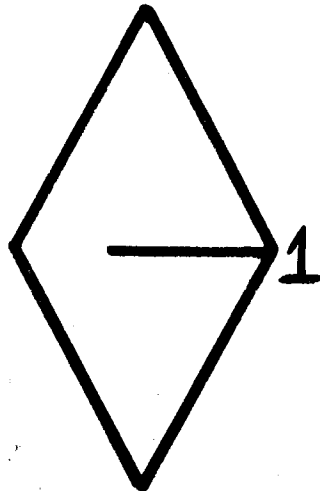
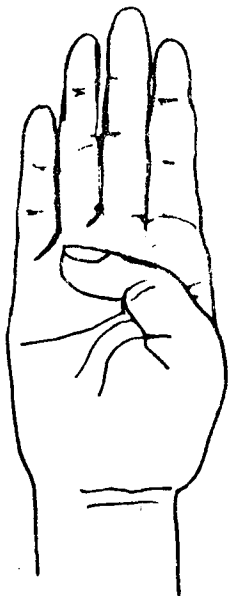



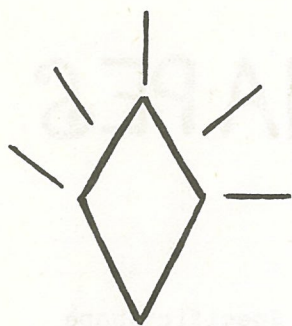

Spread  
Fingers

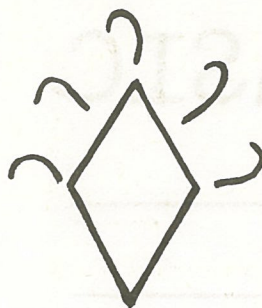

Fingers  
Curved Back

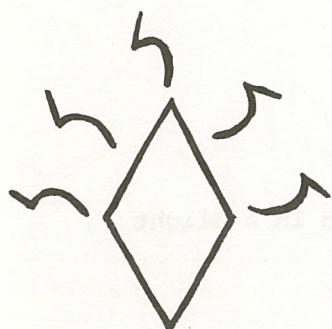

Curved Back  
Bent 1 Joint

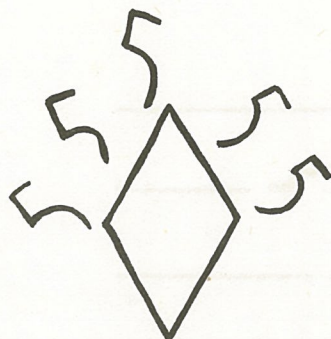

Curved Back  
Bent 2 Joints

## FINGERS IN LINE WITH OR BEHIND THE PALM

---



Fingers Slightly  
Curved Forward



Fingers More  
Curved Forward



Fingers Slightly  
Bent Forward



Fingers More  
Bent Forward

## FINGERS IN FRONT OF THE PALM

# FOUR BASIC FOOT SHAPES

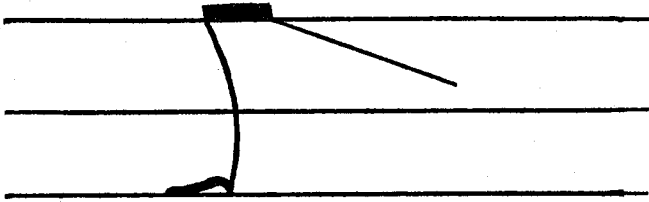

## THE NEUTRAL FOOT

Relaxed Foot With No Specific Shape  
Written By Placing Nothing At The End  
Of The Leg Line

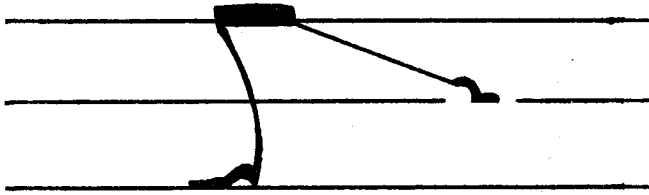

## SLIGHT HALF-TOE FOOT

Toes Slightly Raised In A Slight  
Half Toe Position

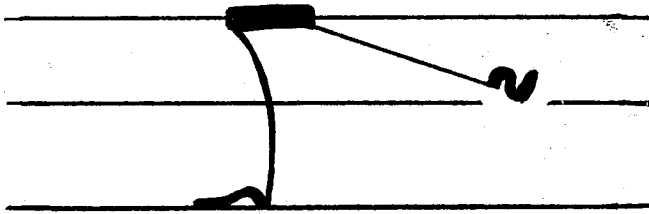

## FULL HALF-TOE FOOT

Toes Raised As Much As Possible  
Arch Stretched

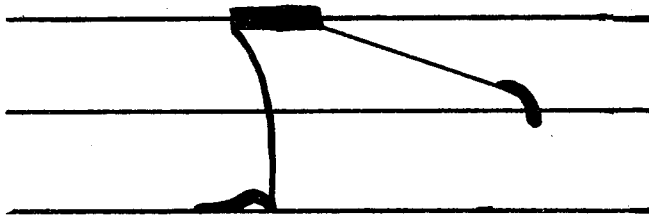

## POINTED FOOT

Foot Completely Stretched And Pointed

See pages 18, 25 and 30 - Feet Viewed On The Planes Of The Room.

The foot can only be shaped in the above four foot shapes. All other foot shapes are variations on these four. When standing, the Neutral Foot becomes the Flat Foot. The other three foot shapes are the same, whether standing or lifted off the ground.

Note: The wrapped foot, diagrammed on page 18, is a variation of the pointed foot, combined with special ankle positioning.



# FEET AND HANDS ON SYMBOLIZED LIMBS

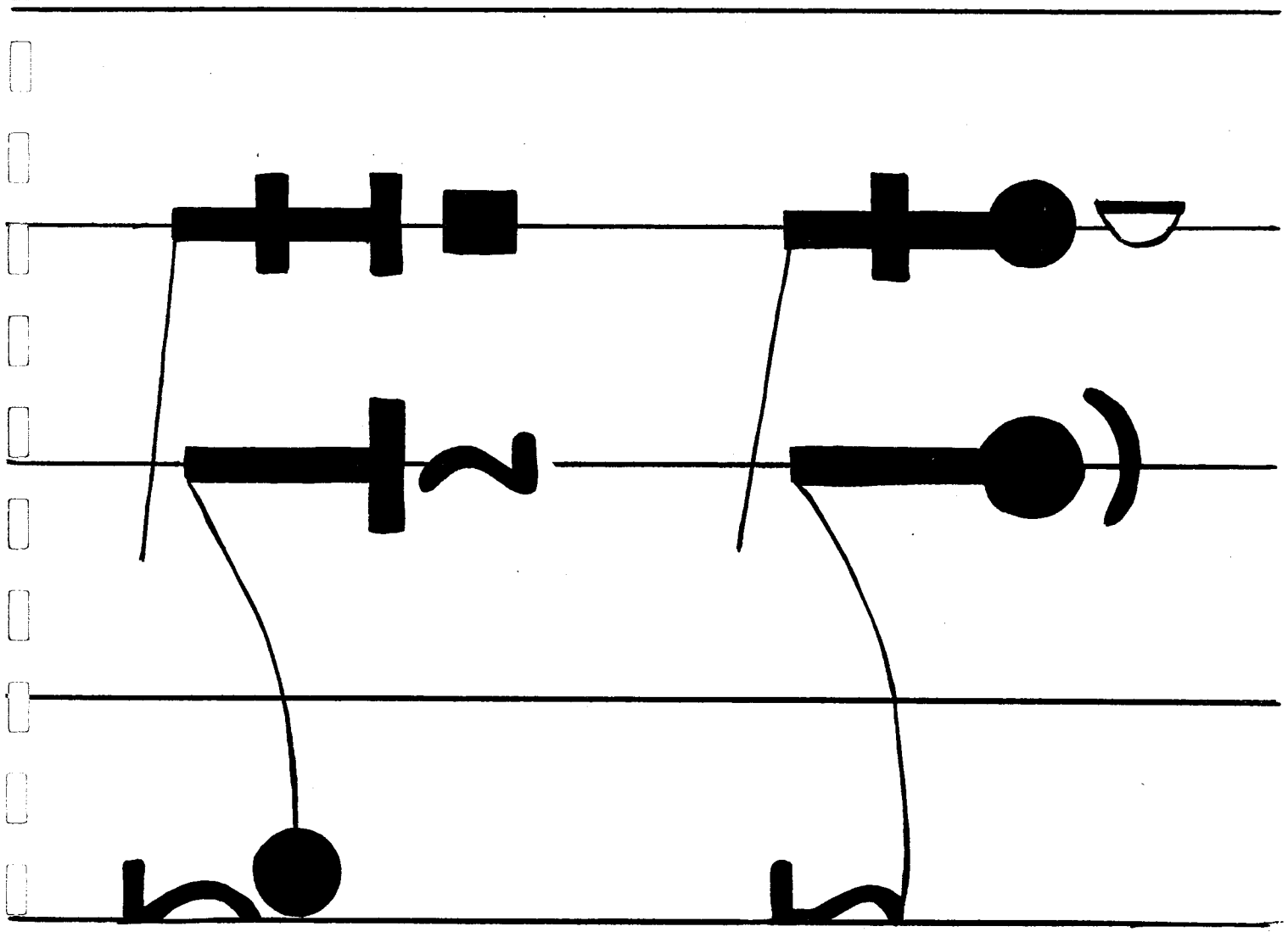

When nothing is written beside the symbolized leg or arm, the hand shape or foot shape is the Neutral Shape. The hand or foot is relaxed in no set shape.

# THE WRISTS

1. The directions of flexing down, up, to the reader, and away, on drawn arms are written as a part of the stick figure, following the drawing rules that govern the stick figure (see p. 42)
2. All directions of flexing on symbolized arms and the directions to the front and back corners on drawn arms, use arrows to notate direction of flexing (see p. 58).

## Wrists On Drawn Arms

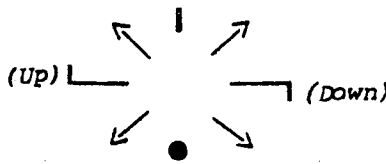

(See Chart p. 42 and 58)

## Wrists On Symbolized Arms

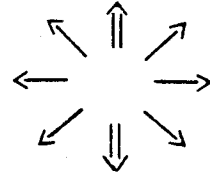

(See Chart p. 58)

### THE WRISTS

#### Wrists On Drawn Arms



Wrist Flexed  
Fingers Down

Wrist Flexed  
Fingers Up

Wrist Flexed  
Fingers To Audience

Wrist Flexed  
Fingers To Back Wall



Wrist Twisted  
Fingers To Front Corner

Wrist Twisted  
Fingers To Back Corner

#### Wrists On Symbolized Arms

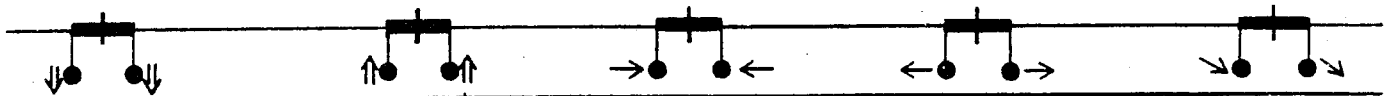

Wrist Flexed  
Fingers Down

Wrist Flexed  
Fingers Up

Wrist Flexed  
Fingers In

Wrist Flexed  
Fingers Out

Wrist Flexed  
Fingers To  
Front Corner



# THE WRISTS

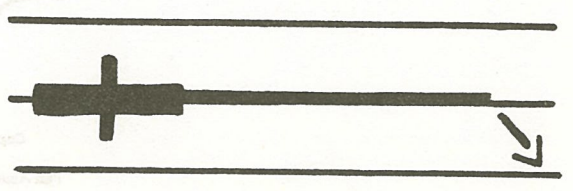
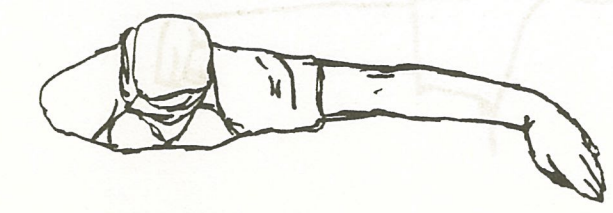
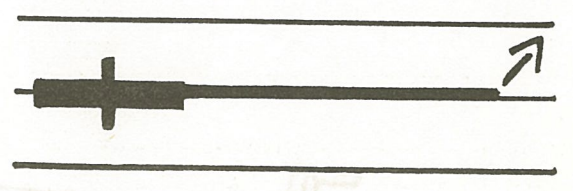
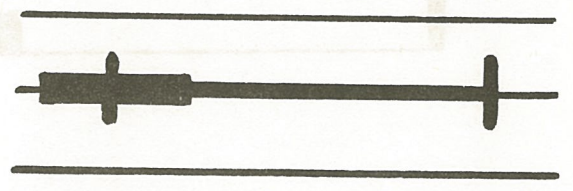
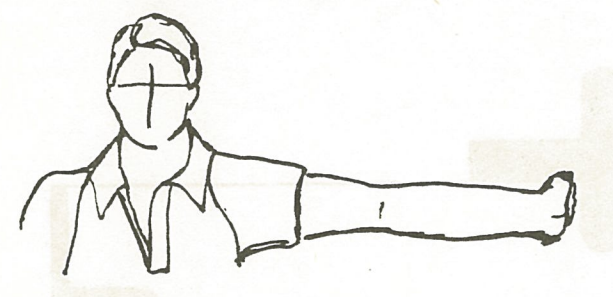
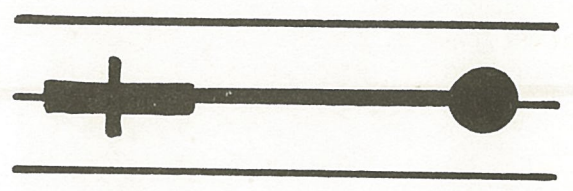
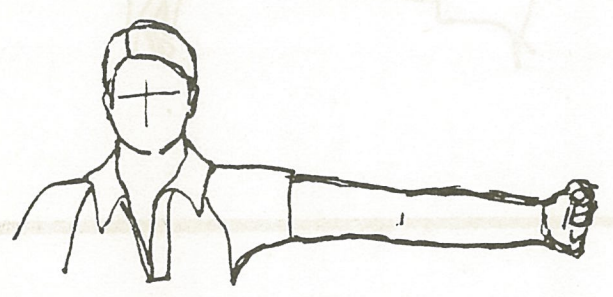
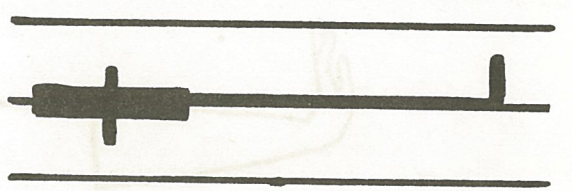
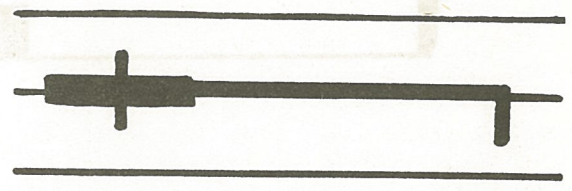
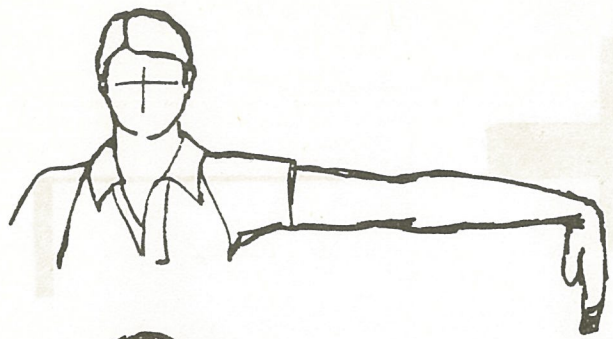

# THE WRISTS

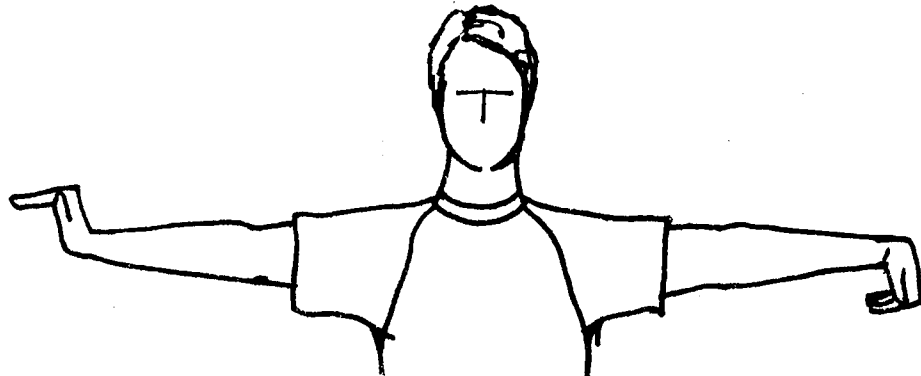
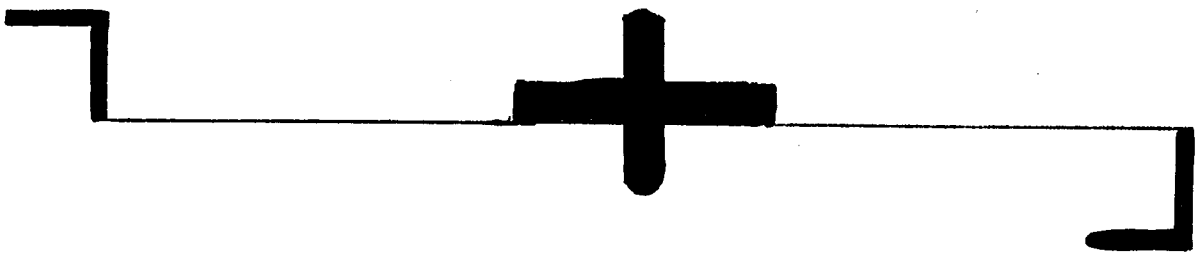
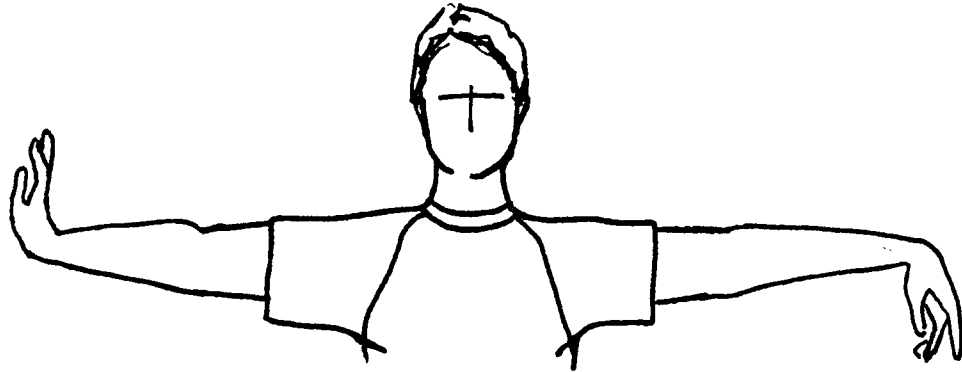
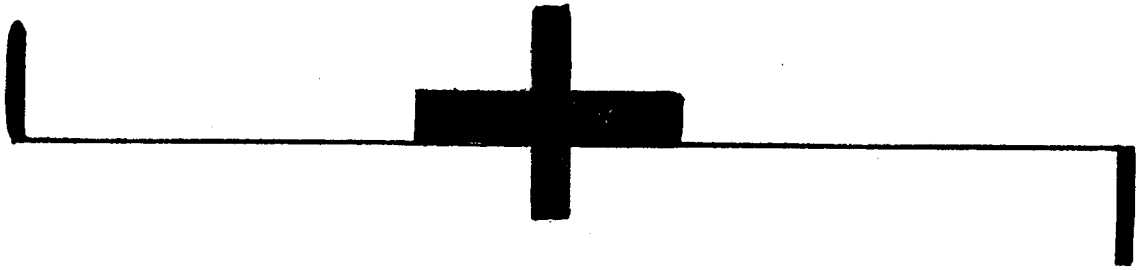

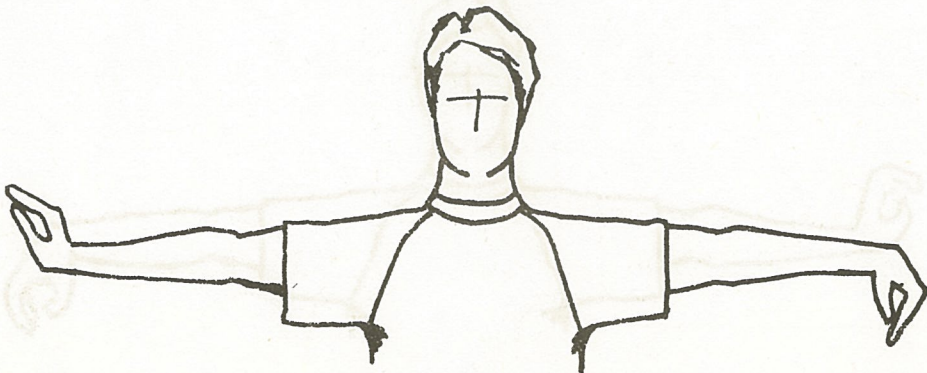
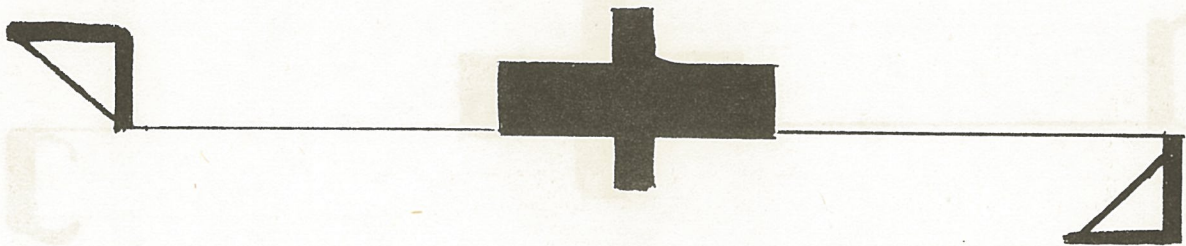
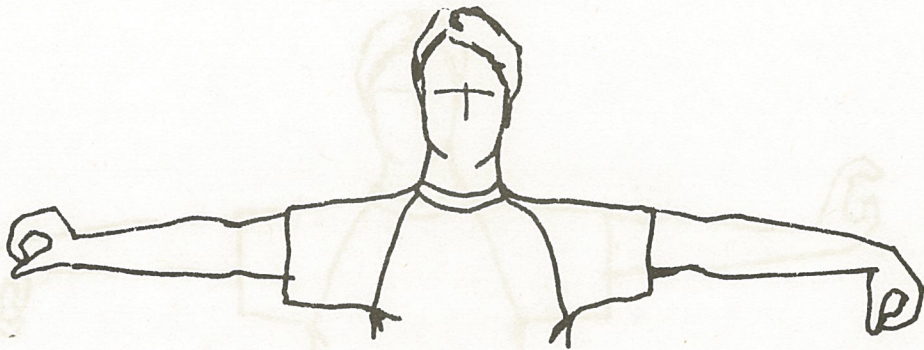
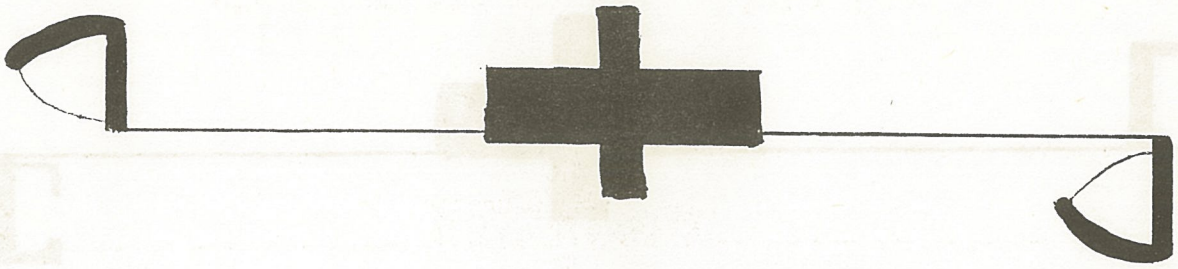

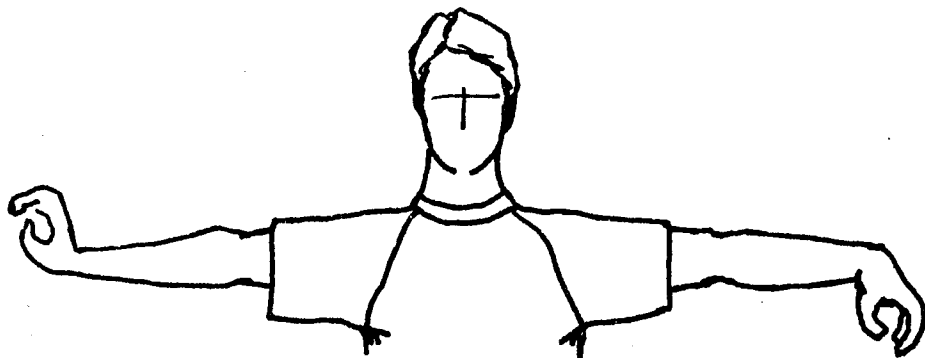
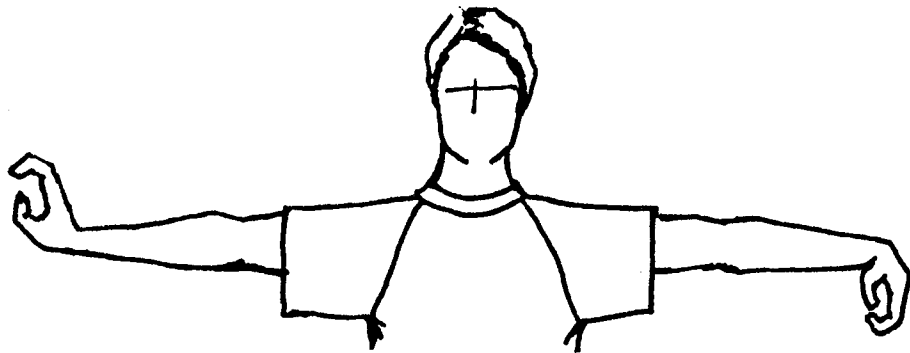



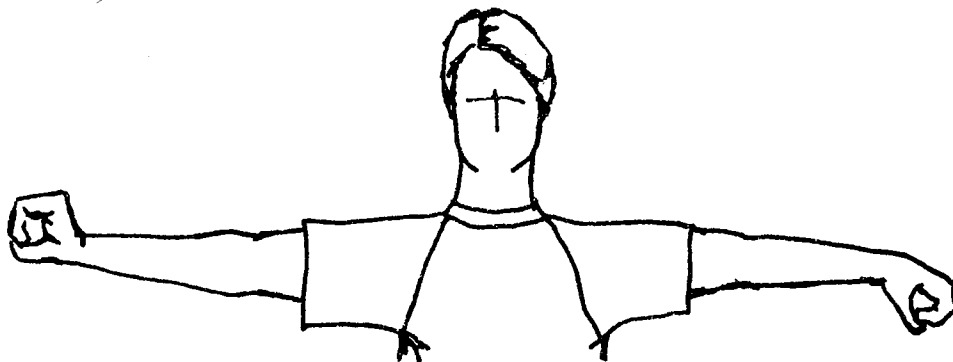
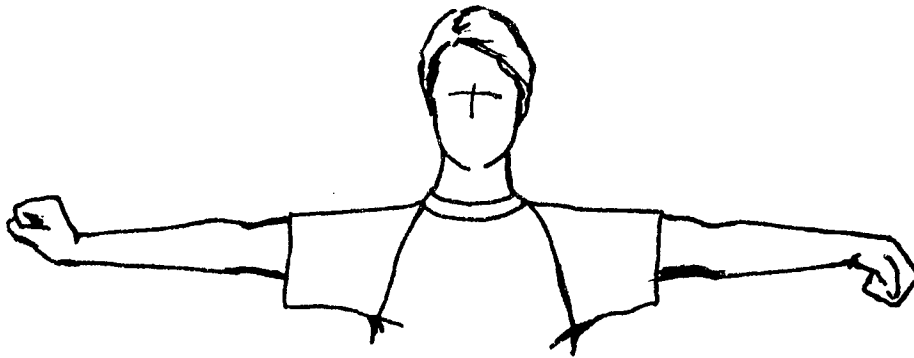
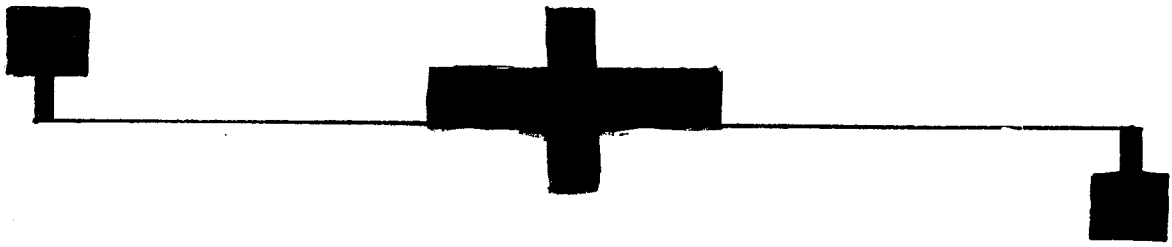

2  
\*  
1



1\*2

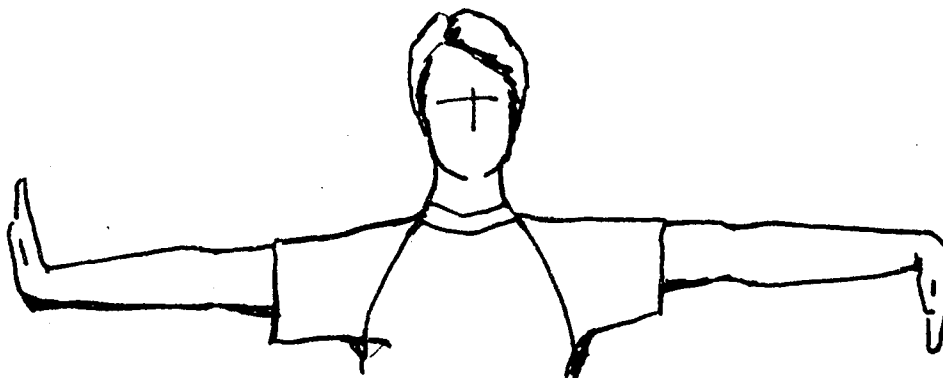
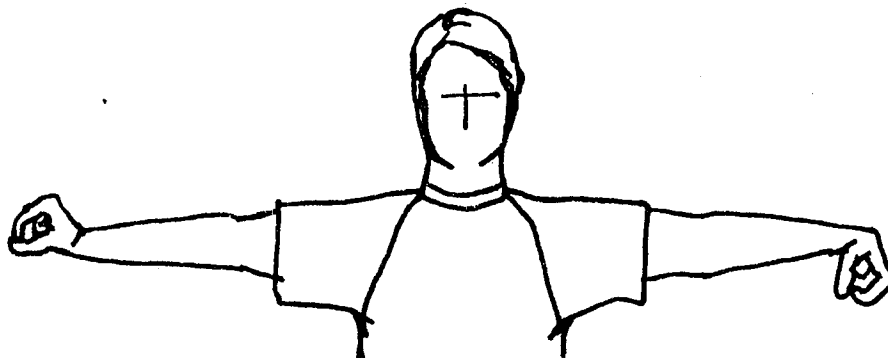

\*Note: The little triangular ("V" shape) symbol shown here represents "THE FLAT HAND" from the side view.

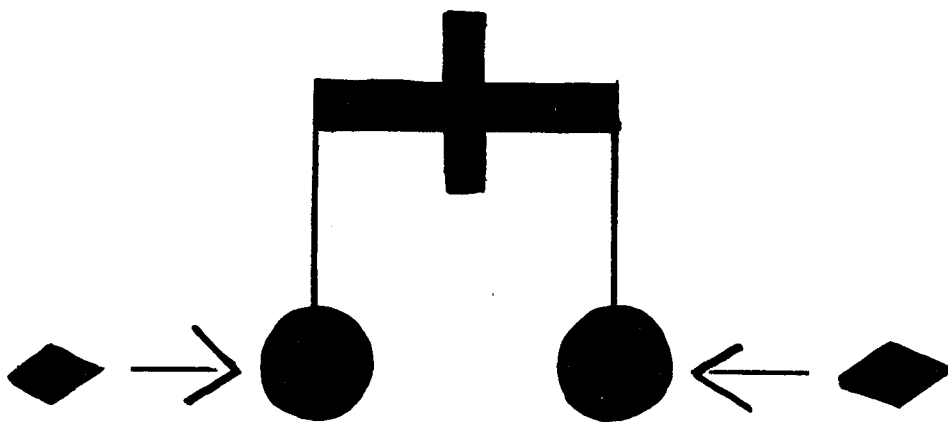
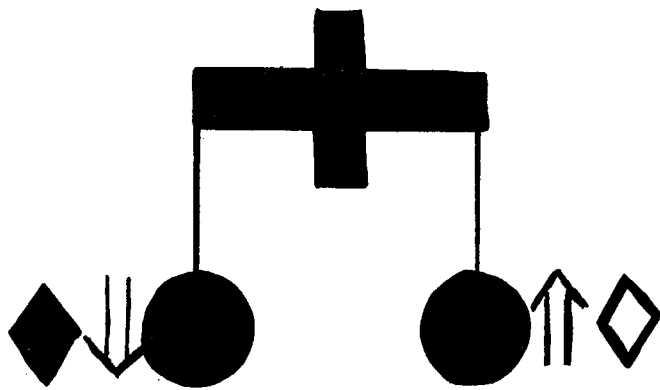

# THE ANKLES

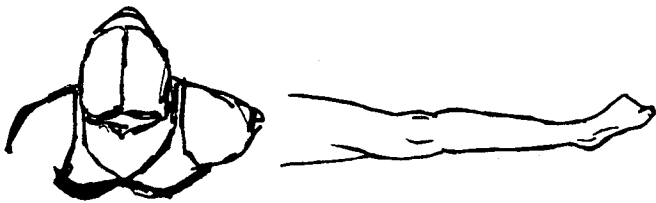
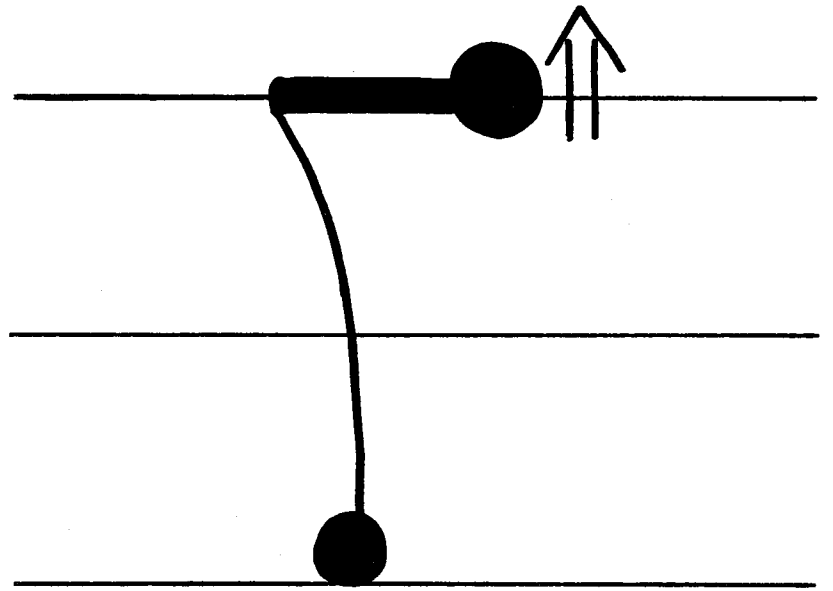
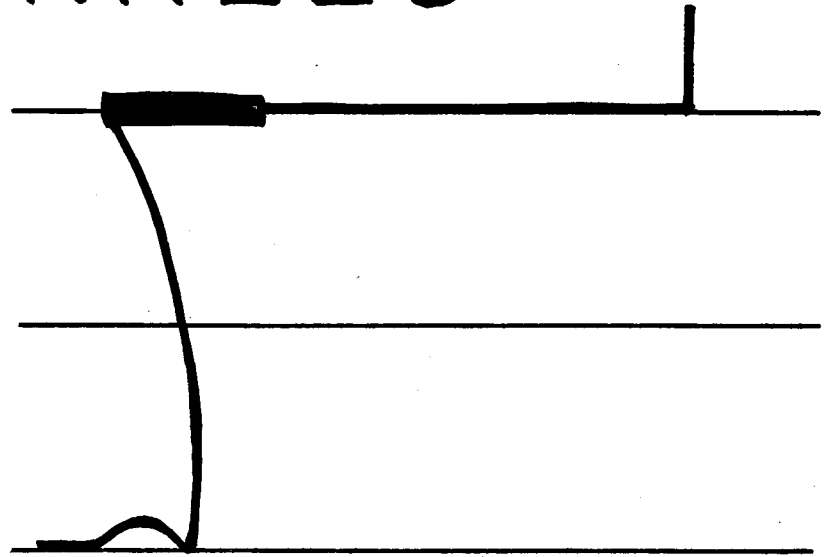
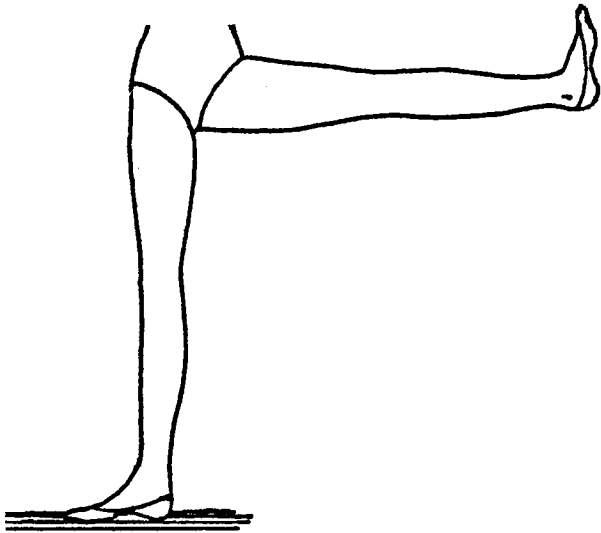

**DIAGONAL PLANE  
SEEN FROM OVERHEAD**

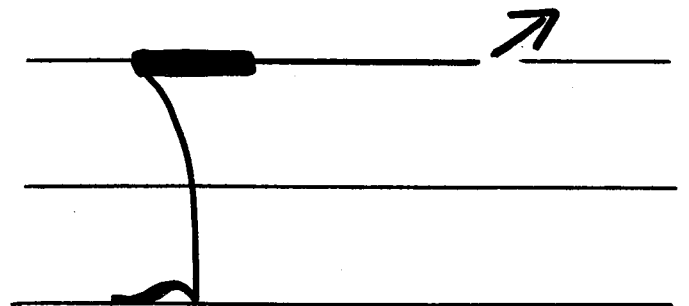



# THE ANKLES

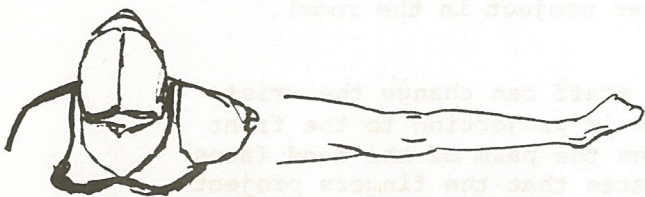
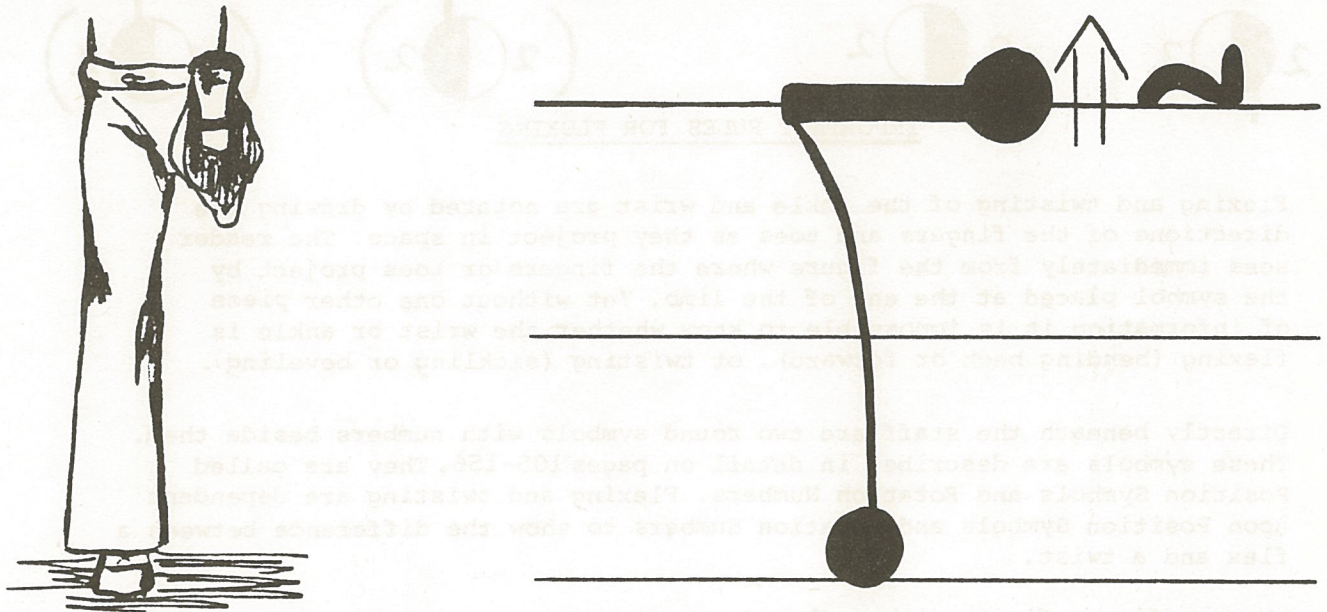
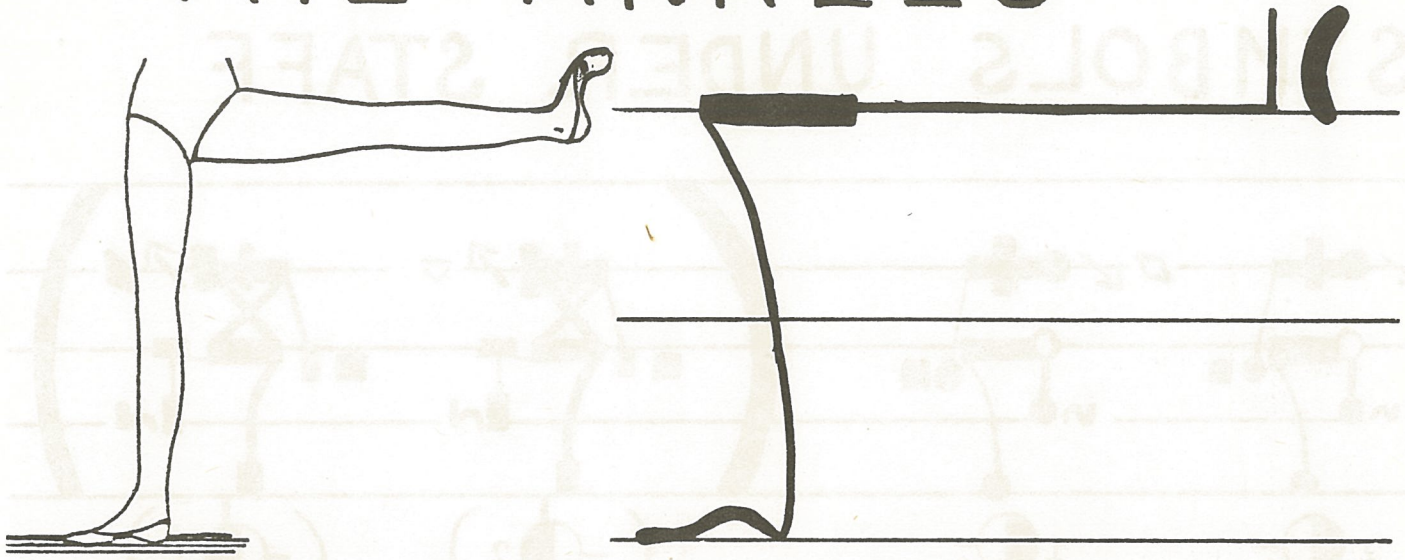

## DIAGONAL PLANE SEEN FROM OVERHEAD

# FLEXING DEPENDENT UPON SYMBOLS UNDER STAFF

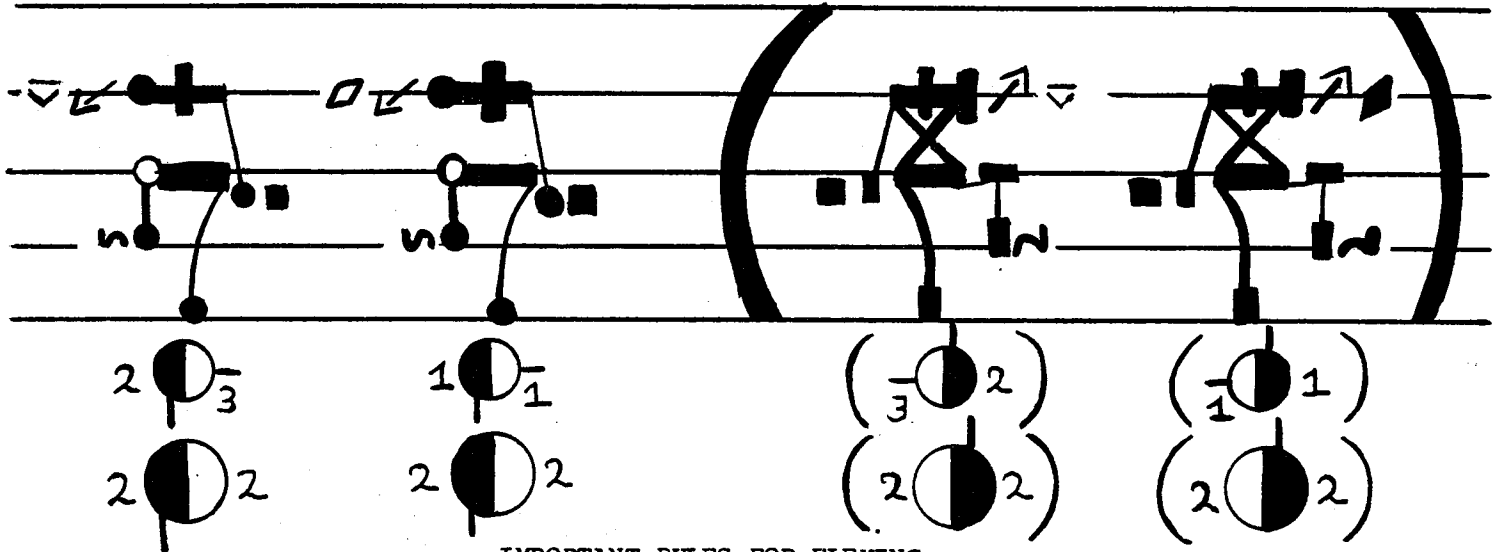

## IMPORTANT RULES FOR FLEXING

Flexing and twisting of the ankle and wrist are notated by drawing the directions of the fingers and toes as they project in space. The reader sees immediately from the figure where the fingers or toes project by the symbol placed at the end of the limb. Yet without one other piece of information it is impossible to know whether the wrist or ankle is flexing (bending back or forward), or twisting (sickling or beveling).

Directly beneath the staff are two round symbols with numbers beside them. These symbols are described in detail on pages 105-156. They are called Position Symbols and Rotation Numbers. Flexing and twisting are dependent upon Position Symbols and Rotation Numbers to show the difference between a flex and a twist.

When reading a figure with a flexed or twisted wrist or ankle, the reader must first glance below the figure to find the direction of the arm or leg from the Position Symbol, and the rotation of the limb from the Rotation Number. Then the reader looks to the figure for the direction of the flex or twist itself (the direction the fingers or toes project in the room).

The simple change of a Rotation Number under the staff can change the wrist or ankle from a flex to a twist. Example: The arm is projecting to the front wall of the room. A number 2 under the staff means the palm of the hand faces down. The notation at the end of the arm line states that the fingers project to the front corner of the room. When the palm is facing down, the wrist must twist to direct the fingers to the front corner of the room. Now the number under the staff changes from 2 to 1. A number 1 means that the baby finger of the hand is to the ground. When the baby finger is facing down, the wrist must flex (bend back) to direct the fingers to the front corner of the room.

# STANDING ON HEELS

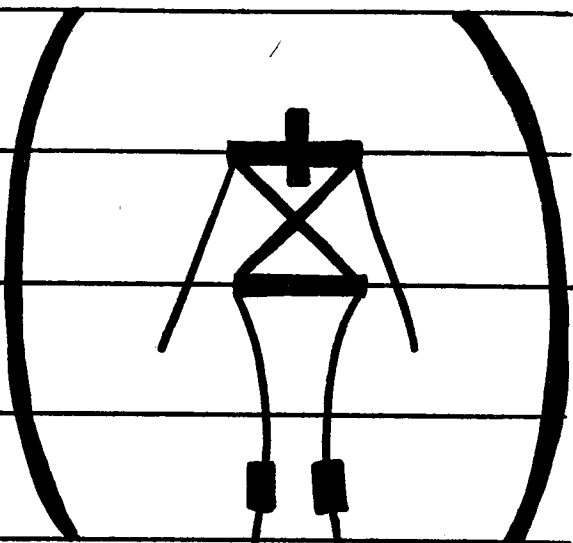
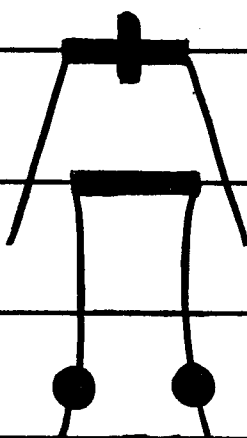
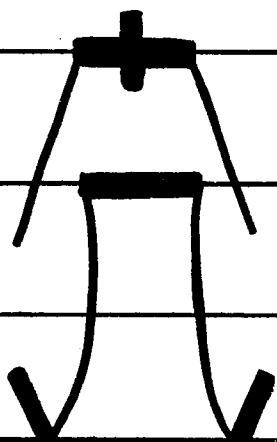

## DIRECTION COMBINATIONS

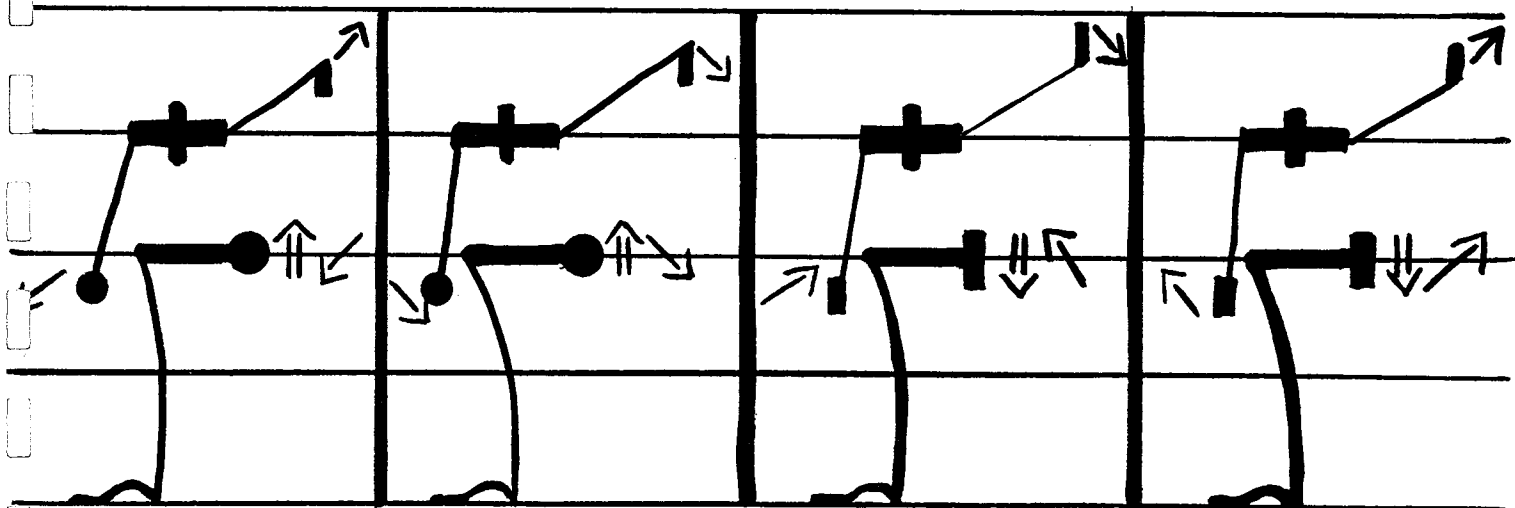

# THE LIMBS IN SUMMARY . . . .

## Following Same Logic

There is a central logic to the notation of the stick figure in Sutton Dance Writing which is also applied to the notation of Wrist and Ankle Variants. A quick explanation of this central logic will simplify learning these Variants.

1. When the whole leg or arm is extended straight in various directions:
  - a. the leg or arm is drawn when extended to the corners or side walls
  - b. the leg or arm is represented by a dark dot when extended to the front wall (the audience)
  - c. the leg or arm is represented by a straight vertical line when extended to the back wall

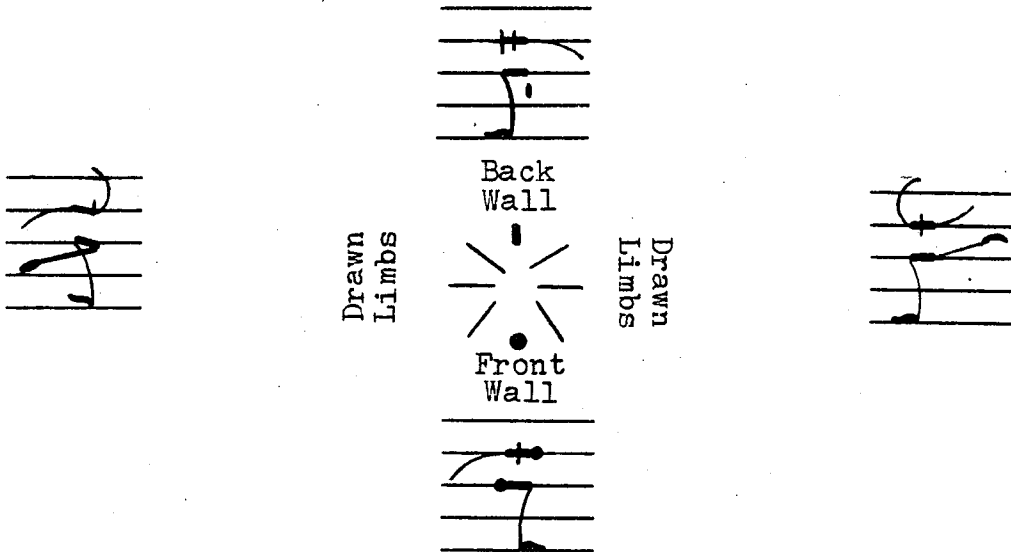

2. When the upper part of the leg or arm remains close to the body while the lower part of the leg or arm extends in various directions (bent legs or arms):
  - a. the lower part of the leg or arm is drawn when extended to the corners or side walls
  - b. the lower part of the leg or arm is represented by a dark dot when extended to the front wall (the audience)
  - c. the lower part of the leg or arm is represented by a straight vertical line when extended to the back wall

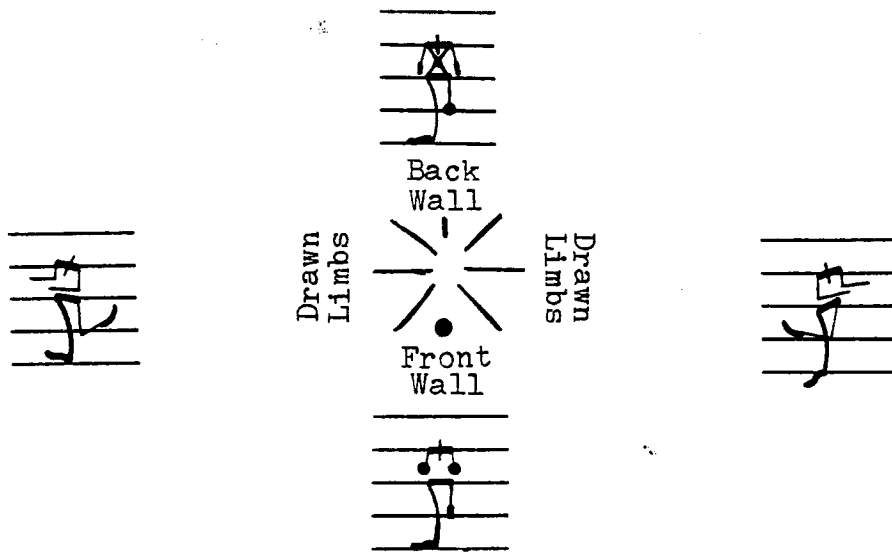

3. When only the hand or foot is directed in various directions:
- the hand or foot is drawn when directed to the corners or side walls
  - the hand or foot is represented by a dark dot when directed to the front wall (the audience)
  - the hand or foot is represented by a straight vertical line when directed to the back wall

This is the logic behind notation of Wrist and Ankle Variants.

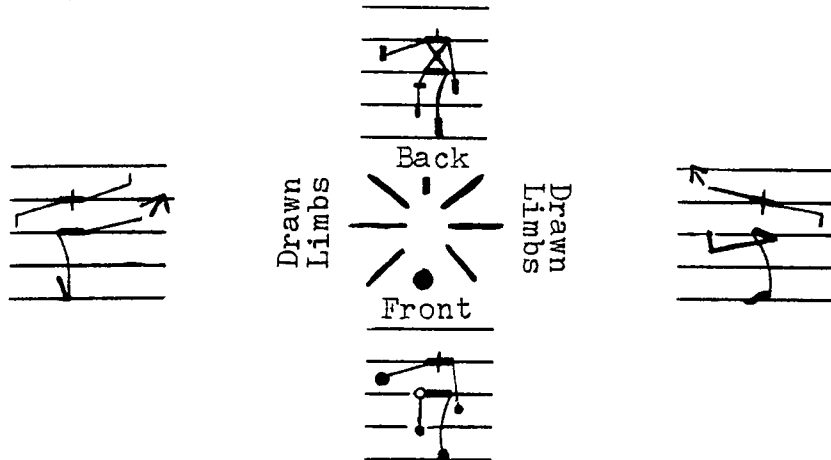

Drawn from the three previous examples, three simple rules summarize the central logic in the system:

- Rule 1: Whenever the fingers or toes are directed in any direction other than straight to the audience or straight to the back wall, the limb, or the part of the limb in line with the fingers or toes, is drawn.
- Rule 2: Whenever the fingers or toes are directed straight to the audience, the limb, or the part of the limb in line with the fingers or toes, is represented by a dark dot.
- Rule 3: Whenever the fingers or toes are directed straight to the back wall, the limb, or the part of the limb in line with the fingers or toes, is represented by a straight vertical line.

# THE TORSO

## BENDING FORWARD FACING FRONT

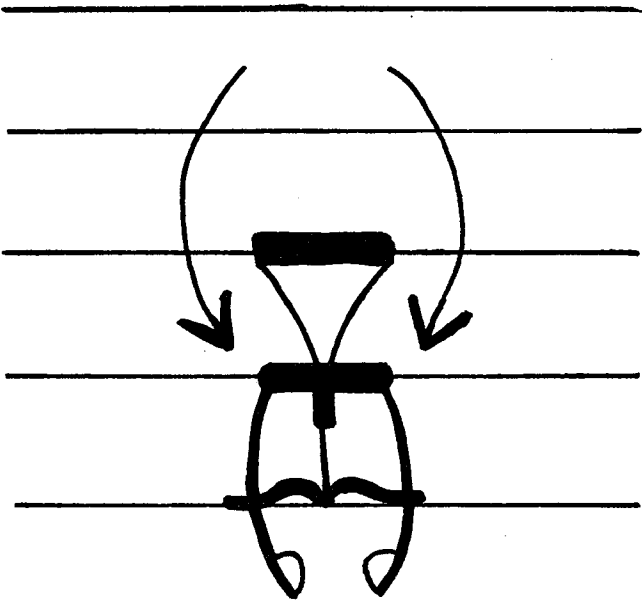

## BENDING BACK FACING FRONT

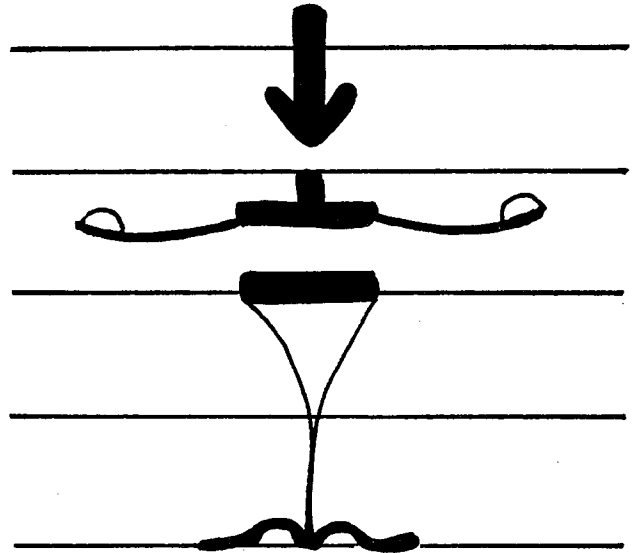

## BENDING SIDE FACING FRONT

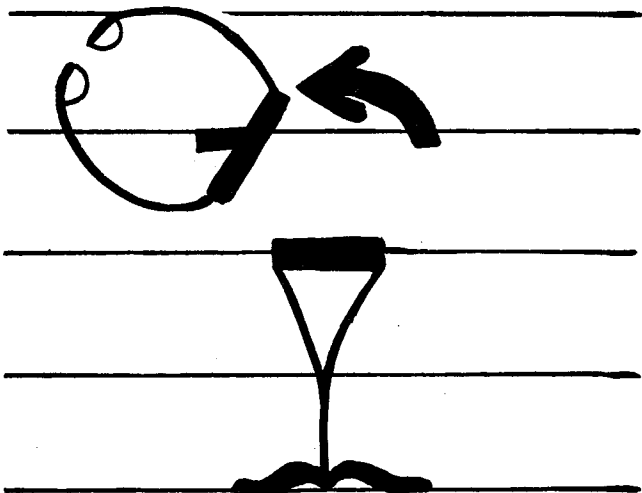

## TWISTING

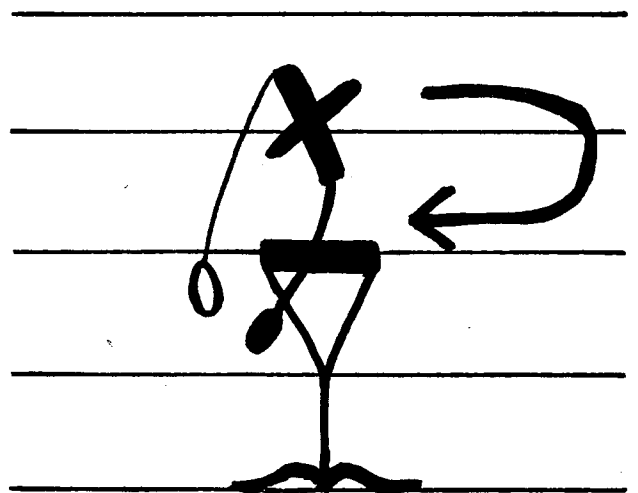



# BENDING FORWARD FACING CORNER

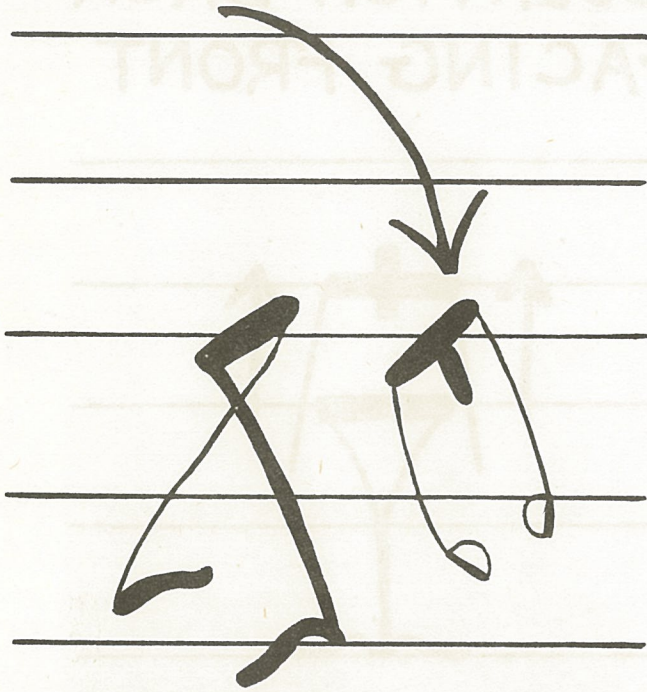

# BENDING BACK FACING CORNER

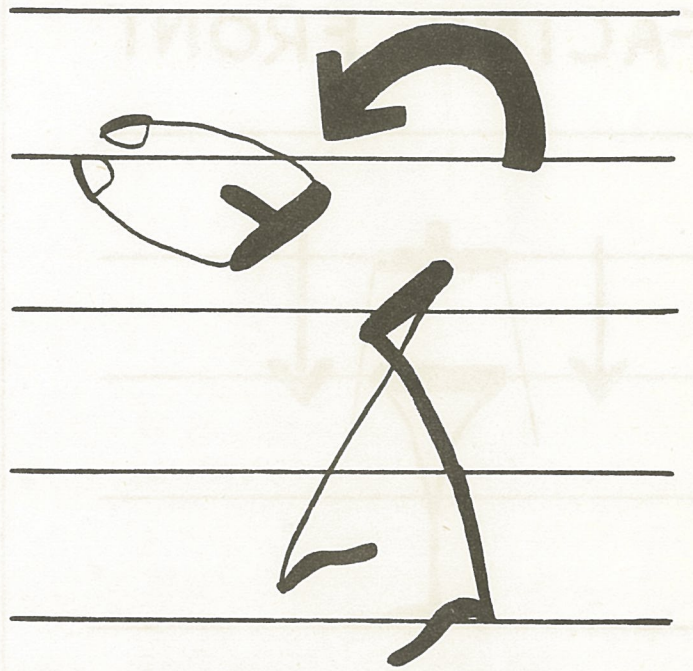

# BENDING SIDE FACING CORNER

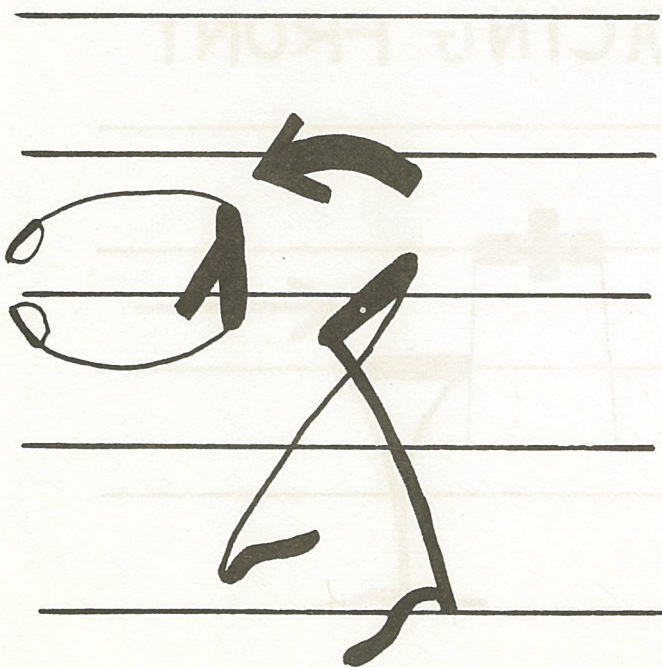

# TWISTING FACING CORNER

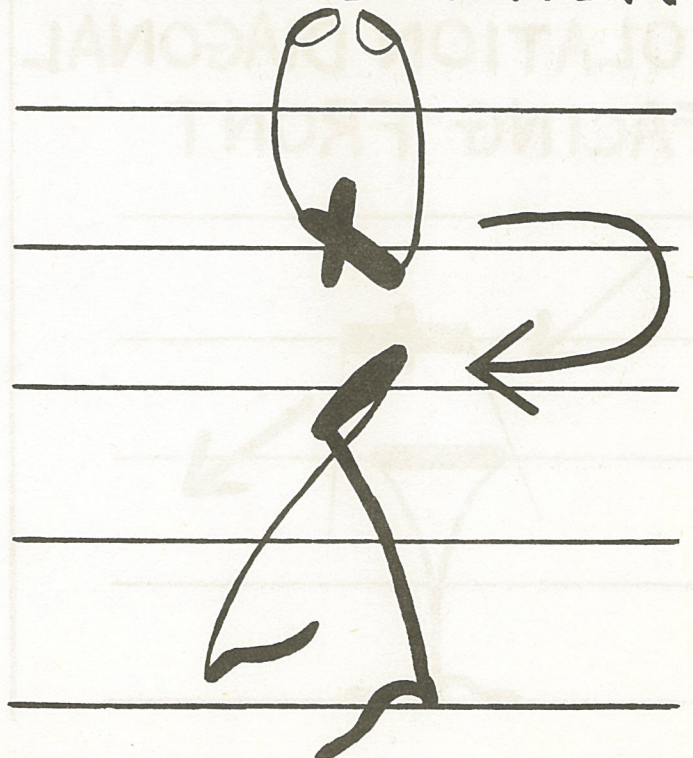

# THE TORSO

ISOLATION FRONT  
FACING FRONT

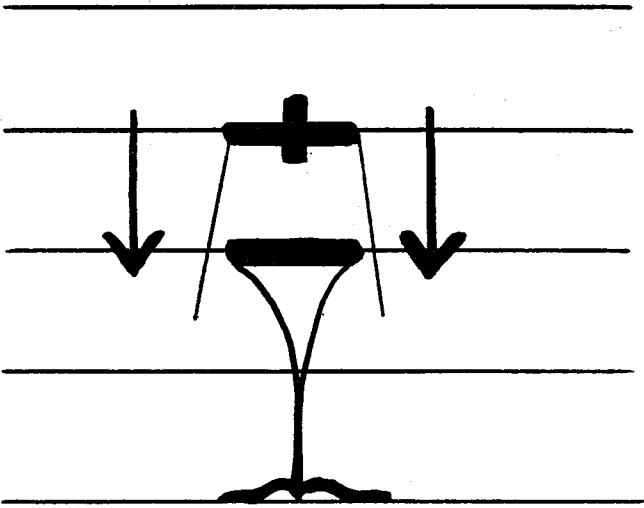

ISOLATION BACK  
FACING FRONT

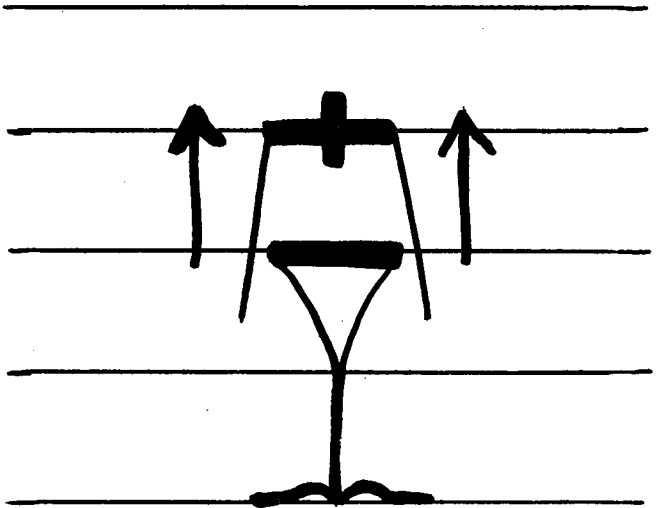

ISOLATION DIAGONAL  
FACING FRONT

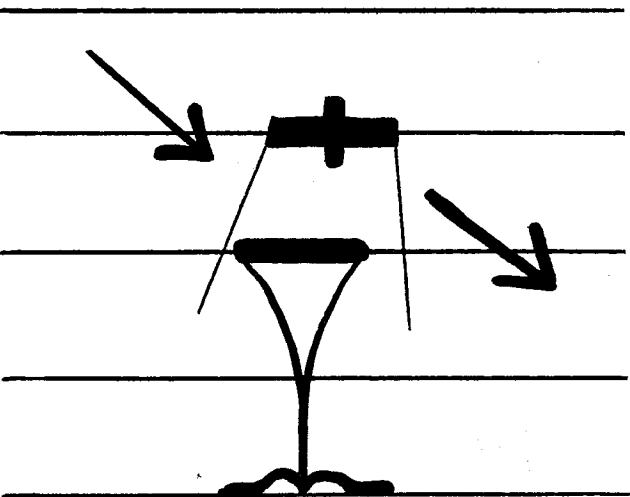

ISOLATION SIDE  
FACING FRONT

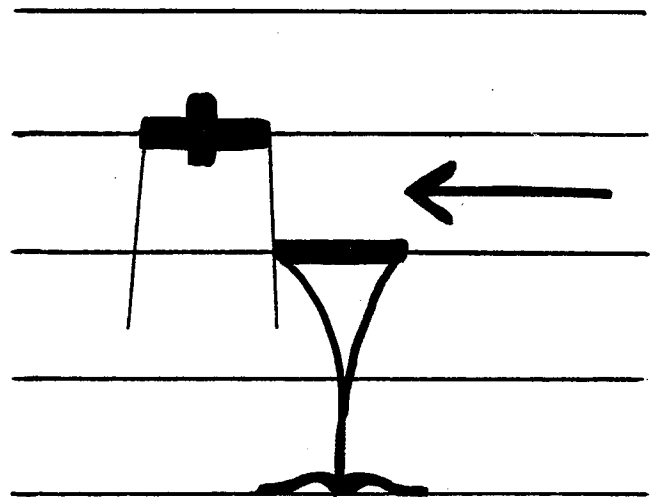



# THE TORSO

## ISOLATION FRONT FACING CORNER

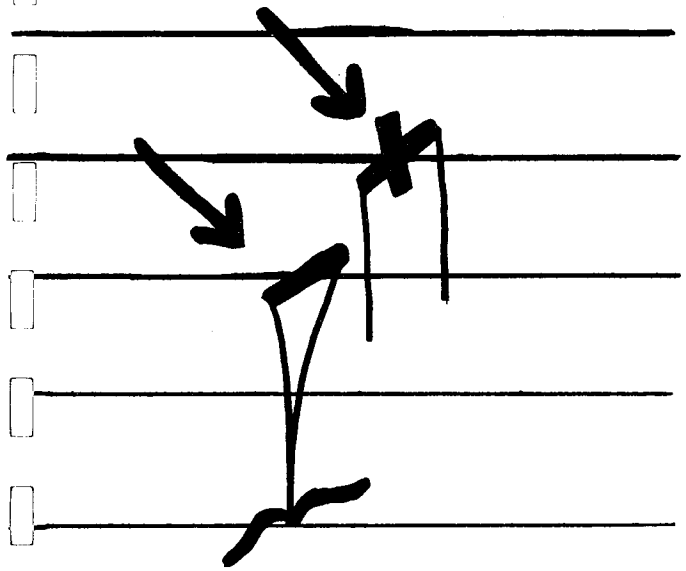

## ISOLATION BACK FACING CORNER

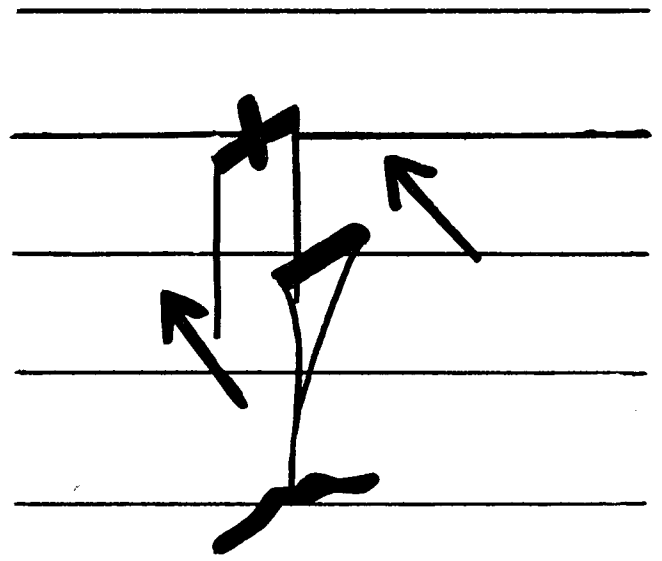

## ISOLATION DIAGONAL FACING CORNER

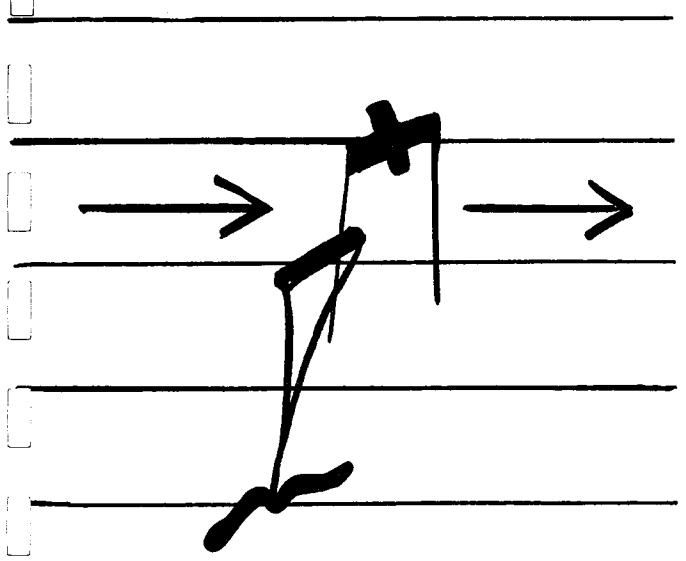

## ISOLATION SIDE FACING CORNER

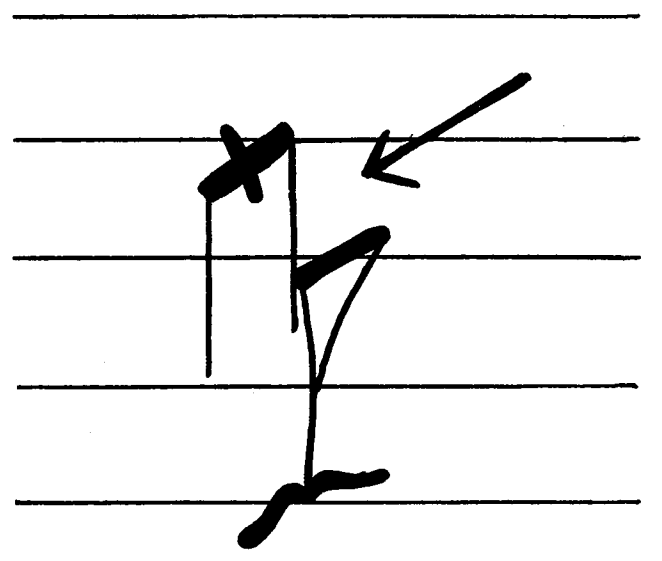

# THE TORSO

Bending  
Forward

Bending  
Side

Bending  
Back

Isolation  
Forward

Isolation  
Front Diagonal



Isolation  
Side

Isolation  
Back Diagonal

Isolation  
Back

Twisting

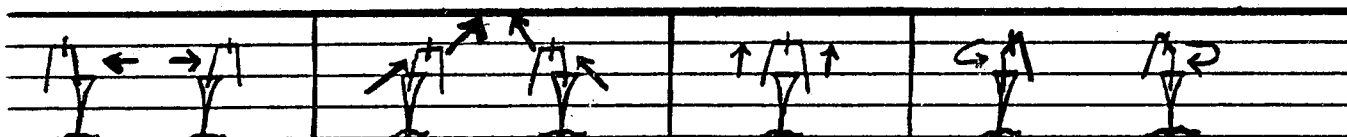

## THE TORSO ARROWS FACING ALL DIRECTIONS

Bending  
Forward  
Facing  
Front  
Wall

Bending  
Forward  
Facing  
Front  
Corner

Bending  
Forward  
Facing  
Side  
Wall

Bending  
Forward  
Facing  
Back  
Corner

Bending  
Forward  
Facing  
Back  
Wall

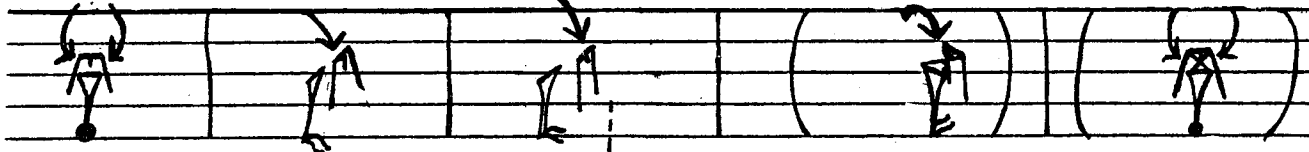

Bending  
Side  
Facing  
Front  
Wall

Bending  
Side  
Facing  
Front  
Wall

Bending  
Side  
Facing  
Front  
Corner

Bending  
Side  
Facing  
Side  
Wall

Bending  
Side  
Facing  
Back  
Corner

Bending  
Side  
Facing  
Back  
Wall



Bending Back Facing Front Wall    Bending Back Facing Front Corner    Bending Back Facing Side Wall    Bending Back Facing Back Corner    Bending Back Facing Back Wall

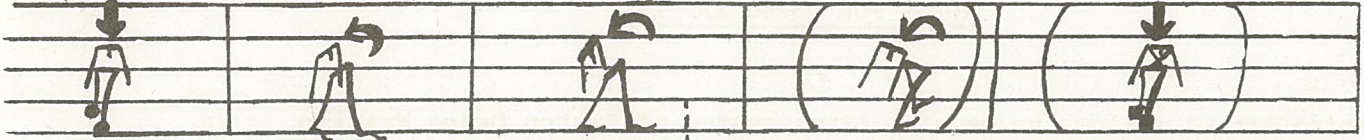

Isolation Forward Facing Front Wall    Isolation Forward Facing Front Corner    Isolation Forward Facing Side Wall    Isolation Forward Facing Back Corner    Isolation Forward Facing Back Wall



Isolation Diagonal Facing Front Corner    Isolation Diagonal Facing Side Corner    Isolation Diagonal Facing Back Corner    Isolation Diagonal Facing Corner    Isolation Diagonal Facing Side Corner    Isolation Diagonal Facing Corner

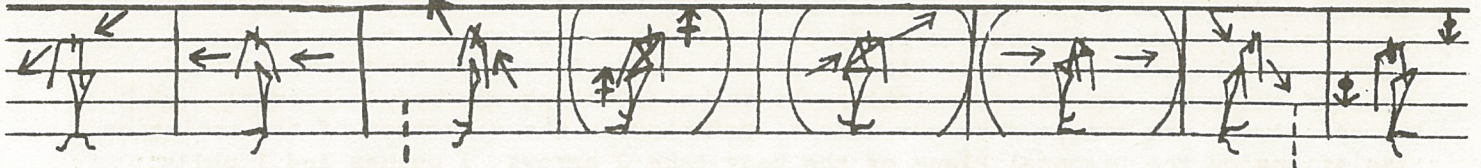

Isolation Side Facing Front    Isolation Side Facing Corner    Isolation Side Facing Side    Isolation Side Facing Corner    Isolation Side Facing Back

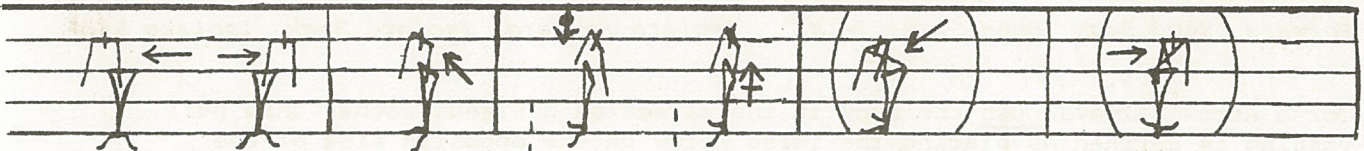

Isolation Back Facing Front    Isolation Back Facing Corner    Isolation Back Facing Side    Isolation Back Facing Corner    Isolation Back Facing Back

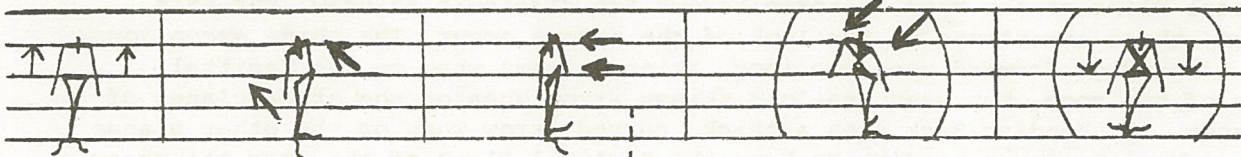

Twisting Facing Front    Twisting Facing Corner    Twisting Facing Side    Twisting Facing Back Corner    Twisting Facing Back Wall





RULES FOR TORSO ARROWS

1. Torso Arrows follow the general arrow system of Sutton Dance Writing, diagrammed in a chart on page 58 . The Torso Arrows do have curves at times, (not shown on the chart on page 58) and they are thin or thick depending upon the direction of the bend or twist.
2. Torso Arrows also differ from the arrow chart on page 58, in that the Torso Arrows relate to the planes of the body, rather than the planes of the room. If the body bends forward on the Sagittal Plane of the body, the Torso Arrow will always look long and skinny, no matter where the person is facing. Torso Arrows are written in relationship to the body, not to the room.
3. Each arrow has a special look to it. Bending forward, along the Sagittal Plane of the body, always uses long skinny arrows. Bending back, along the Sagittal Plane of the body, always uses a strong thick arrow. Bending side, along the Frontal Plane of the body, always uses a short, fat arrow. Twisting uses a curved, skinny arrow. Isolating the torso forward along the body's Sagittal Plane always uses two straight arrows, one on one side of the body and one on the other side, pointing toward the front of the body. Isolating the torso to the back along the body's Sagittal Plane uses two arrows also, pointing toward the back of the body. And torso isolations to the side, along the body's Frontal Plane, always use single straight arrows, pointing in the direction of the isolation. Isolations on the Diagonal Plane of the body take 2 arrows, 1 pushes and 1 pulls.

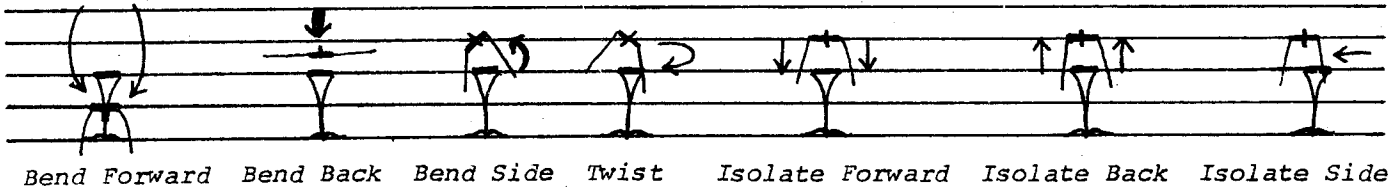

4. Torso Arrows always push the body in the direction desired, rather than pull. Pushing is defined as placing the Torso Arrow on the opposite side of the body to the direction desired. For example, the body bends to the right side. The Bending-Side Arrow will therefore be placed on the figure's left side, pushing the body over to the right.
5. If bending or isolating the torso happens to project the torso along the Sagittal Plane of the room, certain arrows are difficult to draw. For this reason, three exceptions to the look of the arrows occur. The three exceptions are: 1. Bending Forward uses two long, skinny arrows when on the Sagittal Plane of the room, but uses one long skinny arrow when on the other planes of the room. 2. Bending Back uses a thick, curved arrow when on the other planes of the room, but when bending back on the Sagittal Plane of the room the arrow cannot be written in a curve. The curve writes on top of itself and becomes a straight, thick arrow that pushes the shoulders back. 3. Bending and isolating the torso to the side, along the body's Frontal Plane, can be written easily when facing all directions except facing the side wall. When the figure faces the side wall, bending or isolating to the side places the arrows on the Sagittal Plane of the room. There are two ways to write this. First, the figure can be opened up so that the figure and the arrow can be seen clearly. Or second, a dark dot, or a horizontal line can be written on the stem of the arrow. The dark

RULES FOR TORSO ARROWS CONTINUED

dot represents the direction "toward the front wall." The horizontal line represents the direction "toward the back wall."

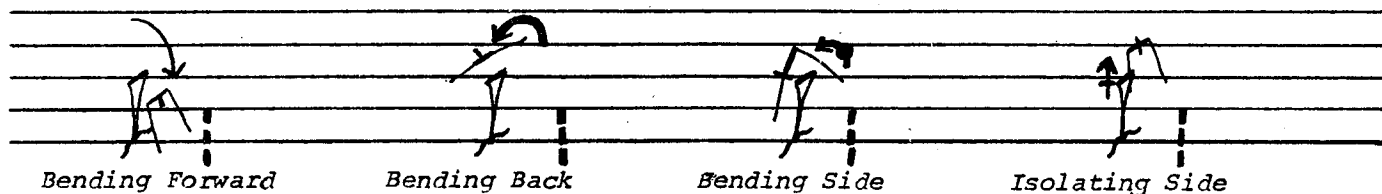

6. Occasionally bending, twisting or isolating arrows push the upper body along the In-Between Planes of the body. In these rare cases, the dotted lines used to notate the In-Between Planes (see pages 45-52) are placed around the arrowhead of the arrow. The figure accompanying the arrow will also be facing the In-Between Direction in most cases:

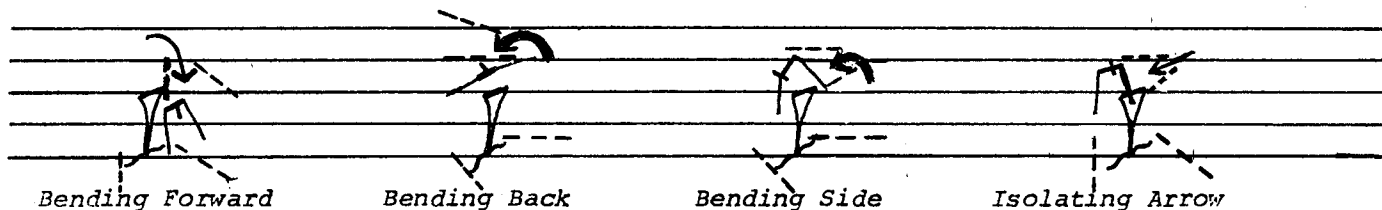

7. Torso Arrows always show the position of the twist, bend or isolation. The arrows are always placed directly beside a figure, and the figure and the arrow together create the position. Torso Arrows are never used as movement symbols, between positions, showing the movement of twisting, bending, etc. They write positions only.

8. Bending is defined as enough tilt in the shoulders to create a stretching feeling in the torso area. Bending always uses bending arrows. It is possible to tilt the shoulders without bending enough to stretch the torso area. In these cases, no Torso Arrow is used. The tilt in the shoulders is drawn visually on the figure without any arrow. The reader knows that there is no stretching of the torso:

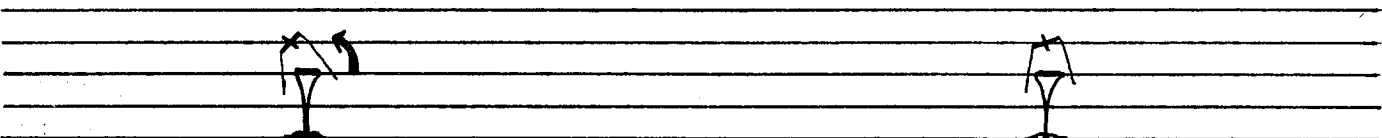

*Bending With Stretch In Torso*

*Small Tilt With No Stretch In Torso*

\*Note: Small tilts are different than large tilts, described on pages 164-168. Small tilts are done without moving the body from its center. Large tilts move the whole body in a unit, in one line, on a tilt. The center of the body is moved from one place to another in a large tilt. Large tilts use special tilting symbols. Small tilts use no symbols at all.



# THE SPINE

## STRETCH UP OF SPINE

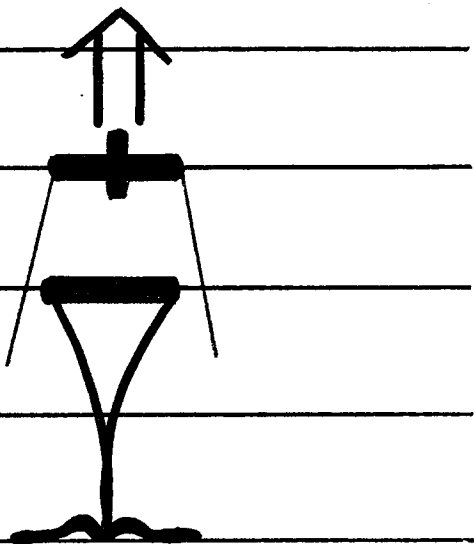

## SINKING DOWN OF SPINE

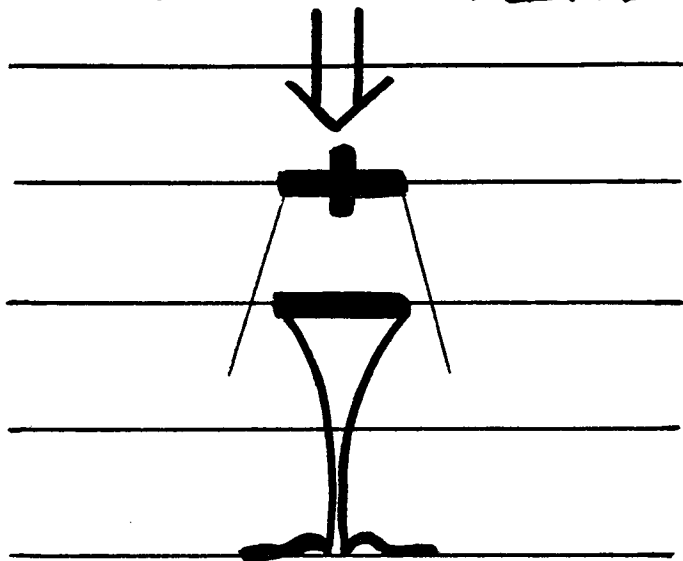

## STRAIGHT SPINE (ASSUMED)

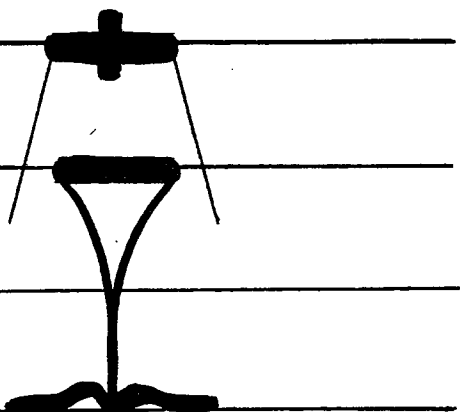

## ROUNDED SPINE

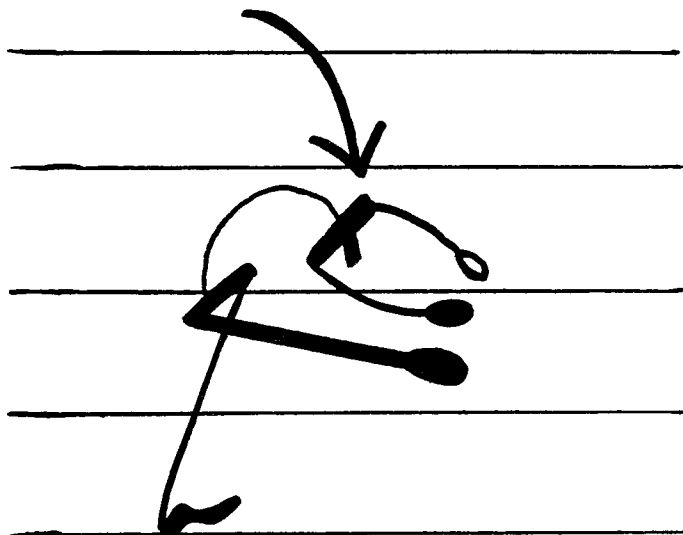

# THE HEAD

Since the head follows the movements of the neck, the majority of head movements are written with the Neck Line only (see page 55). In rare cases, however, the head moves alone, isolating from the neck to create small subtle movements. Notice below that the neck does not move, as the head does:

Head  
Inclined  
Forward

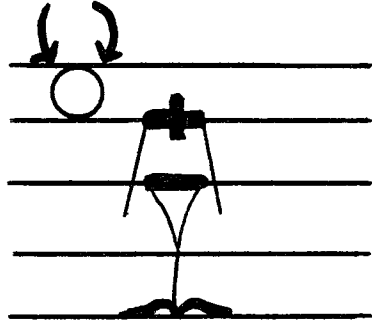

Head  
Inclined  
Forward

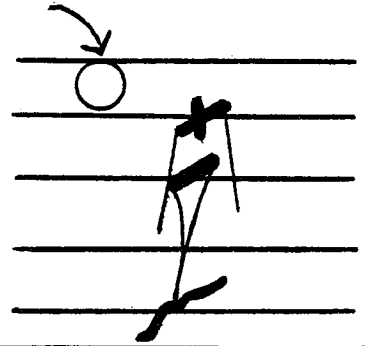

Head  
Inclined  
Side

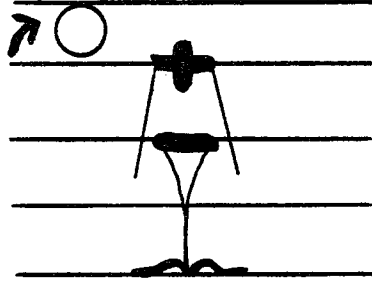

Head  
Inclined  
Side

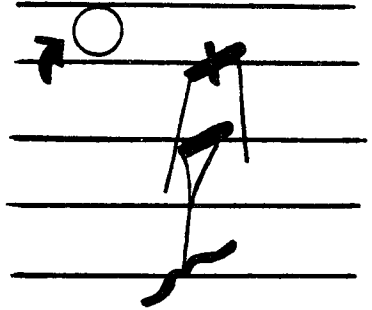

Head  
Inclined  
Back

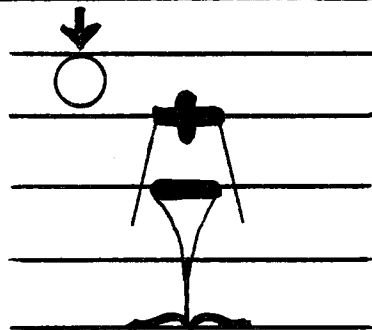

Head  
Inclined  
Back

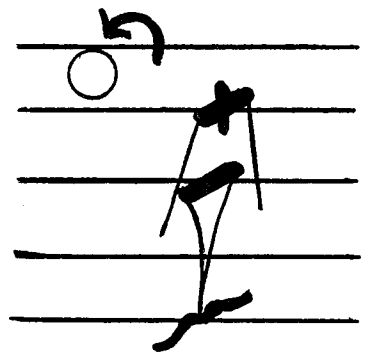

Head  
Rotated

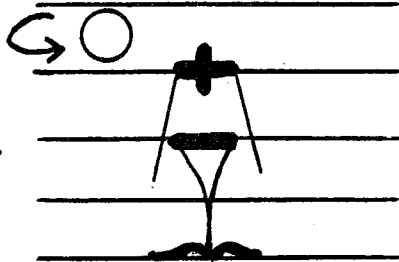

Head  
Rotated

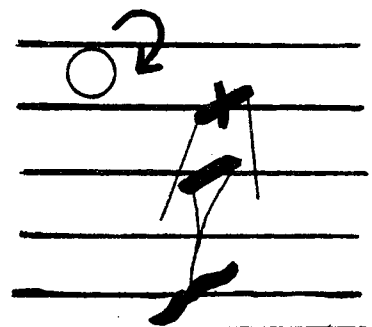



# THE HEAD

Rule One: All subtle movements of the head use arrows. These arrows follow all of the same rules applied to Torso Arrows. They look exactly like Torso Arrows.  
 Rule Two: The head circle is always placed to the reader's left of the figure.  
 Rule Three: The head is always placed in the space above the shoulders of the stick figure. If the figure is standing straight, the head is placed in the highest most space of the staff. If the figure is sitting on the ground, with the shoulders at the Knee Line of the staff, then the head circle is placed in the space between the Knee Line and the Hip Line of the staff.

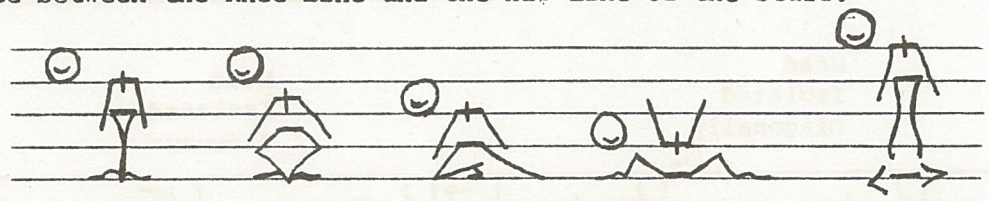

Head  
 Isolation  
 Forward

Head  
 Isolation  
 Forward

Head  
 Isolation  
 Side

Head  
 Isolation  
 Side

Head  
 Isolation  
 Back

Head  
 Isolation  
 Back

Head  
 Isolation  
 Diagonal

Head  
 Isolation  
 Diagonal

# THE HEAD

Head & Neck  
Straight

Head  
Inclined  
Forward

Head  
Inclined  
Sideways

Head  
Inclined  
Backward



Head  
Isolated  
Forward

Head  
Isolated  
Diagonally

Head  
Isolated  
Sideways

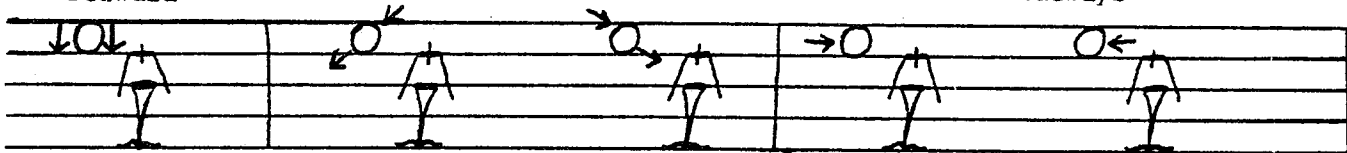

Head  
Isolated  
Diagonally

Head  
Isolated  
Backward

Head  
Rotation



## SUBTLE HEAD MOVEMENTS FACING ALL DIRECTIONS

Head Inclined Forward

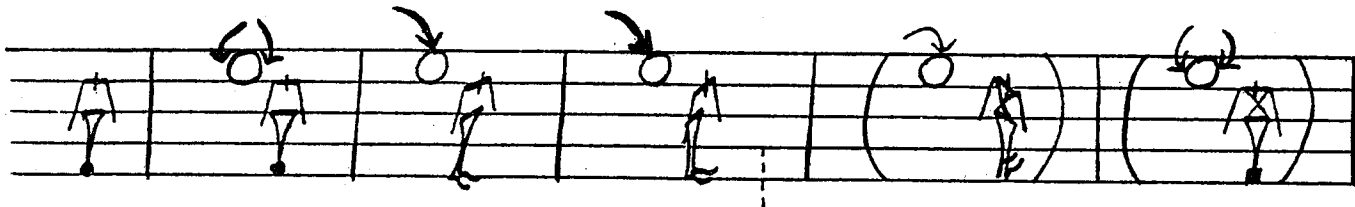

Head Inclined Sideways



Head Inclined Backwards

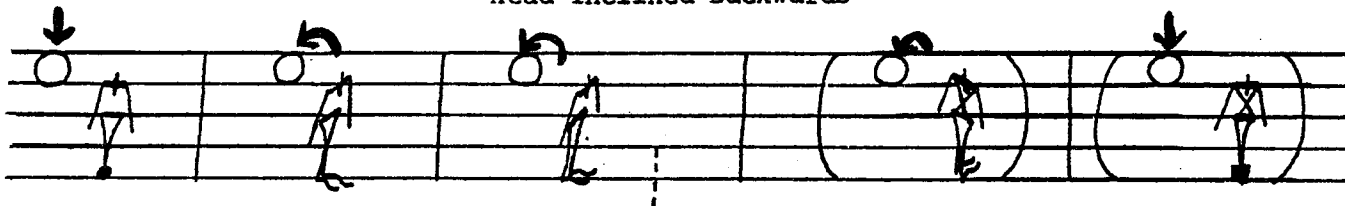

Head Isolated Forward

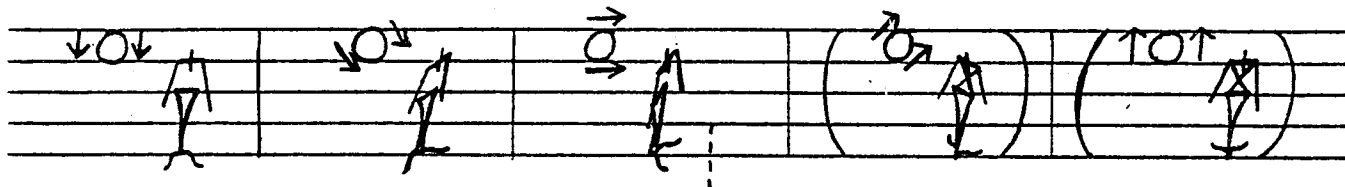

Head Isolated Diagonally

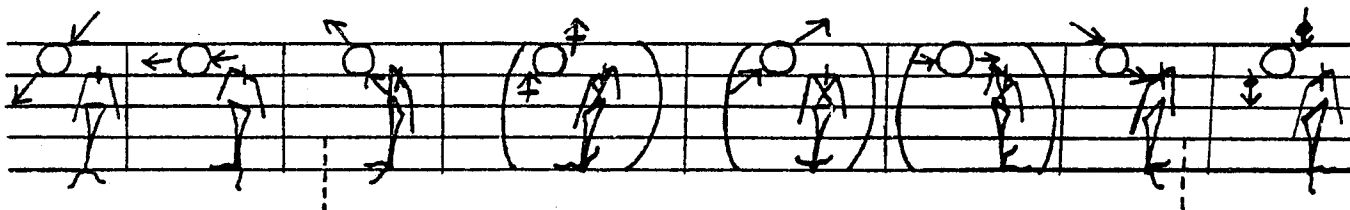

Head Isolated Sideways

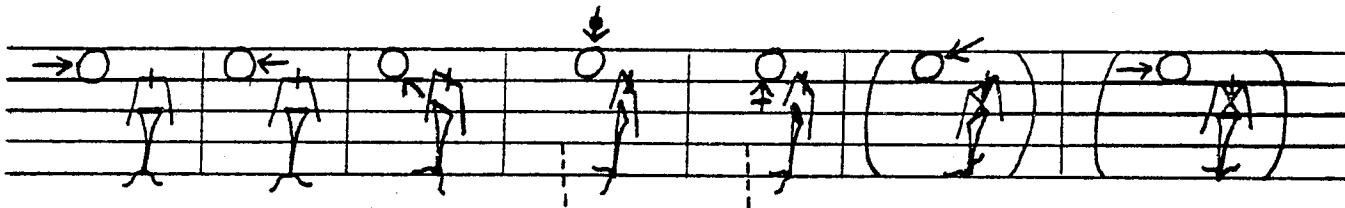

Head Isolated Backwards



Head Rotations

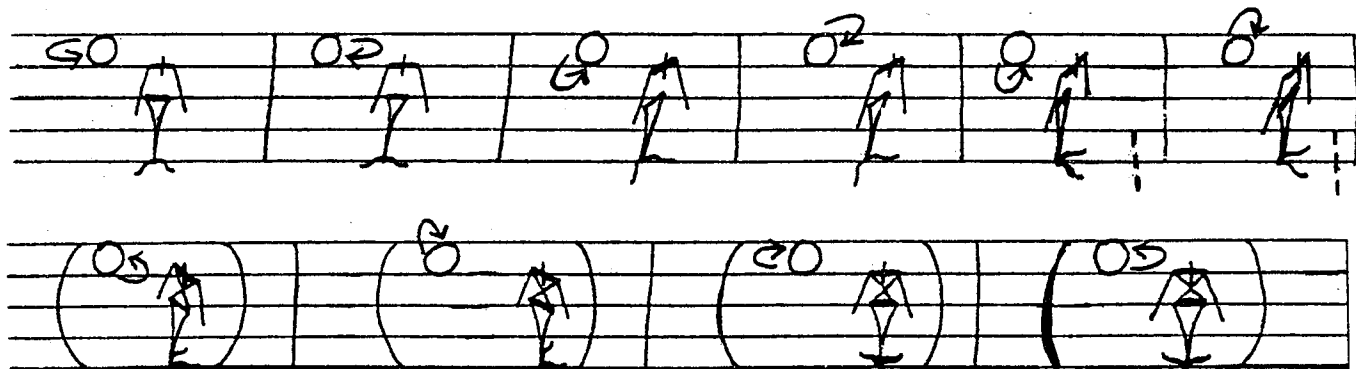

Copyright © 1979 By Valerie J. Sutton  
ALL RIGHTS RESERVED  
Pan American And Universal Copyrights Secured

# POSITION SYMBOLS

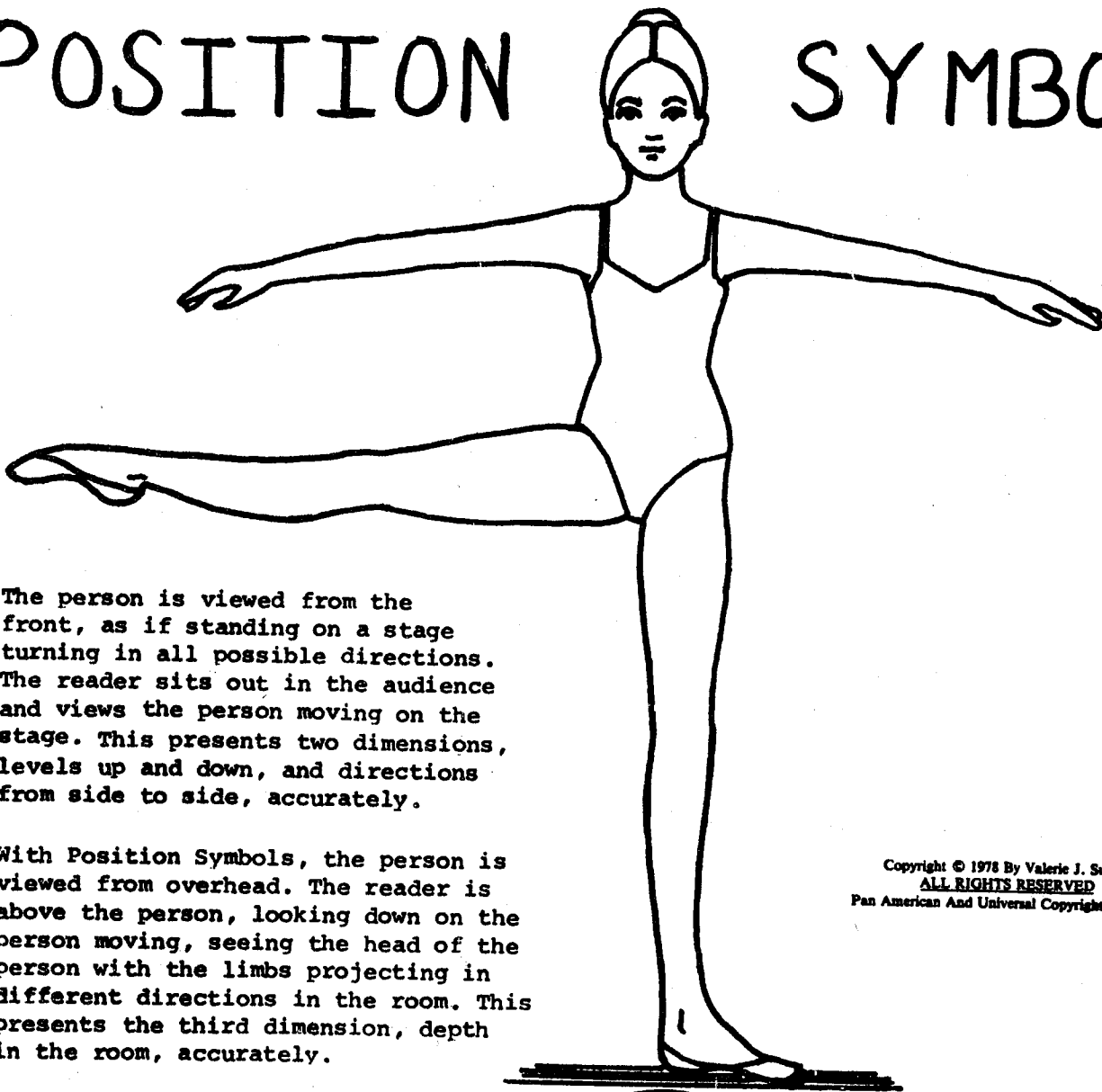

The person is viewed from the front, as if standing on a stage turning in all possible directions. The reader sits out in the audience and views the person moving on the stage. This presents two dimensions, levels up and down, and directions from side to side, accurately.

With Position Symbols, the person is viewed from overhead. The reader is above the person, looking down on the person moving, seeing the head of the person with the limbs projecting in different directions in the room. This presents the third dimension, depth in the room, accurately.

Copyright © 1978 By Valerie J. Sutton  
**ALL RIGHTS RESERVED**  
 Pan American And Universal Copyrights Secured

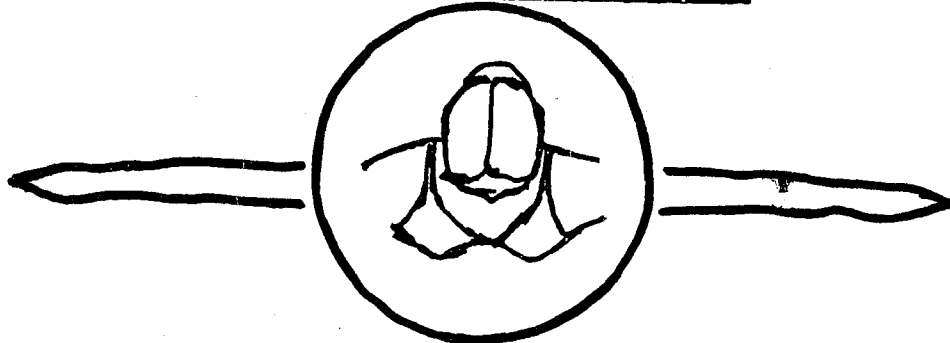

POSITION

SYMBOLS

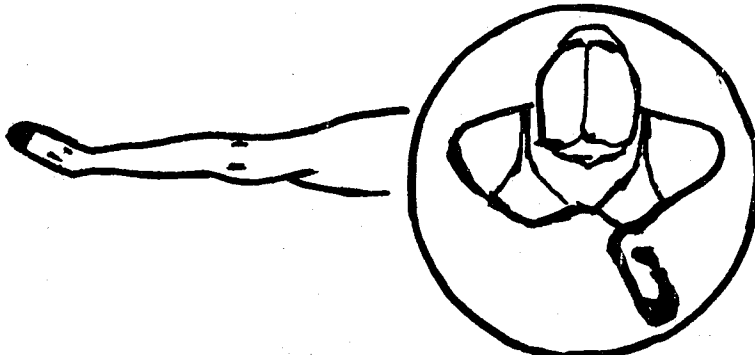

# POSITION

# SYMBOLS

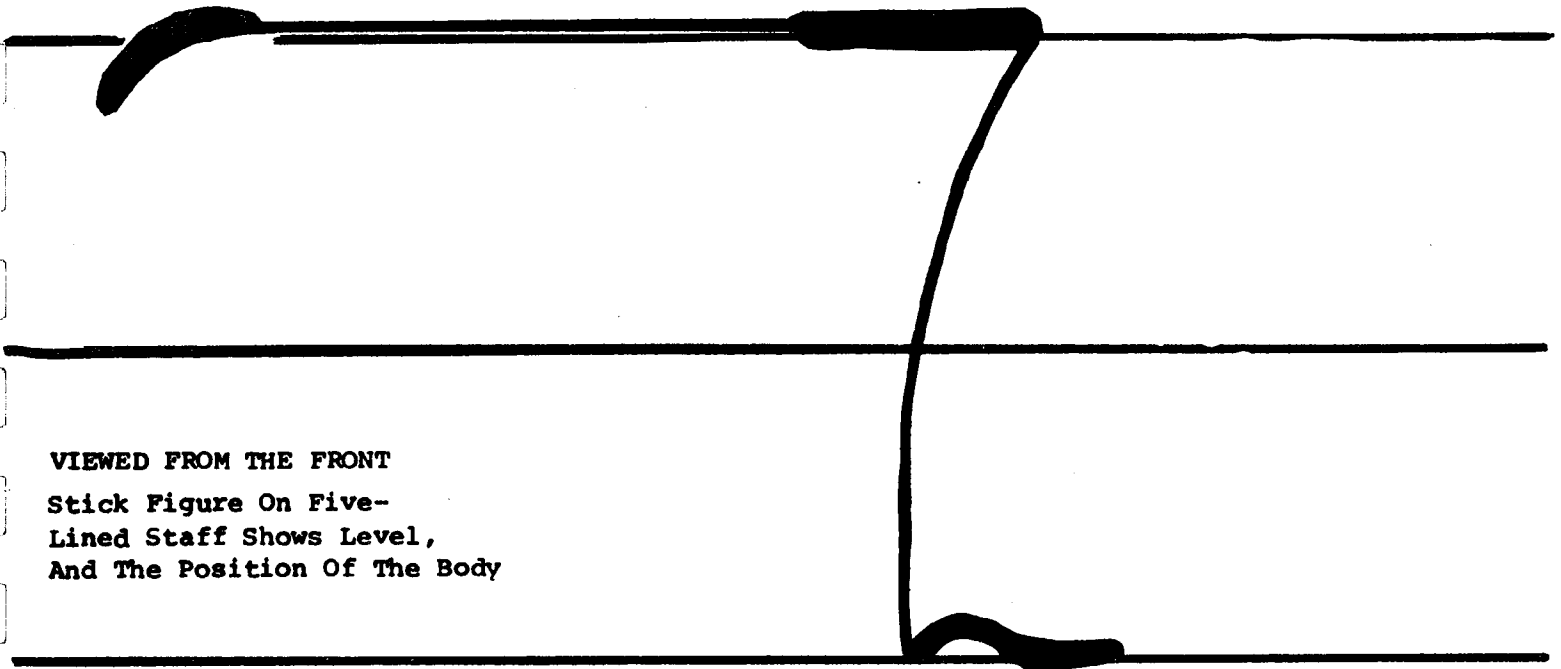

**VIEWED FROM THE FRONT**  
**Stick Figure On Five-**  
**Lined Staff Shows Level,**  
**And The Position Of The Body**

**POSITION SYMBOL**  
**FOR UPPER BODY**  
**Overhead View,**  
**Upper Body, Arms**

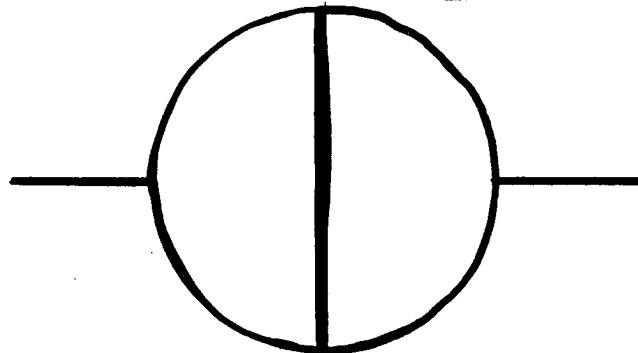

**POSITION SYMBOL**  
**FOR LOWER BODY**  
**Overhead View,**  
**Lower Body, Legs**

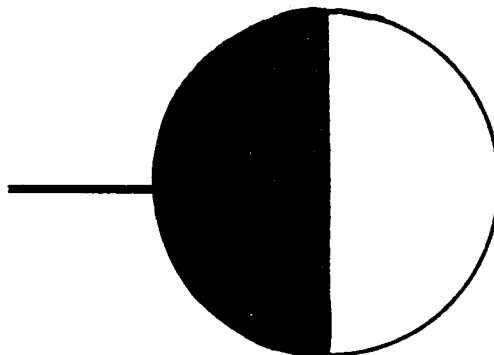

# VIEWPOINTS ON FIGURE

Position Symbols use spotlights to write the depth in and out and up and down. The spotlight from overhead encircles the body in a vertical cylinder of light. The two spotlights from the side wings of the stage create two horizontal cylinders of light that encircle the extremities of the body, the wrists and ankles.

Position Symbols Show The Overhead View, As If Sitting High Above The Figure And Looking Down At The Figure On The Stage.

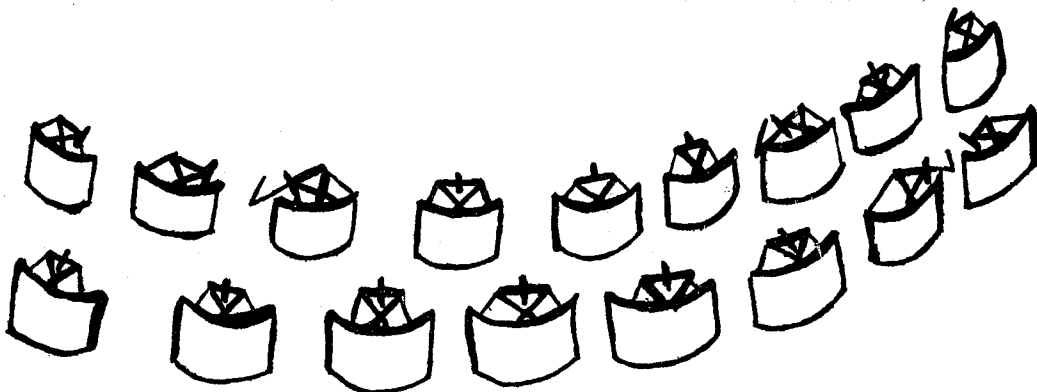
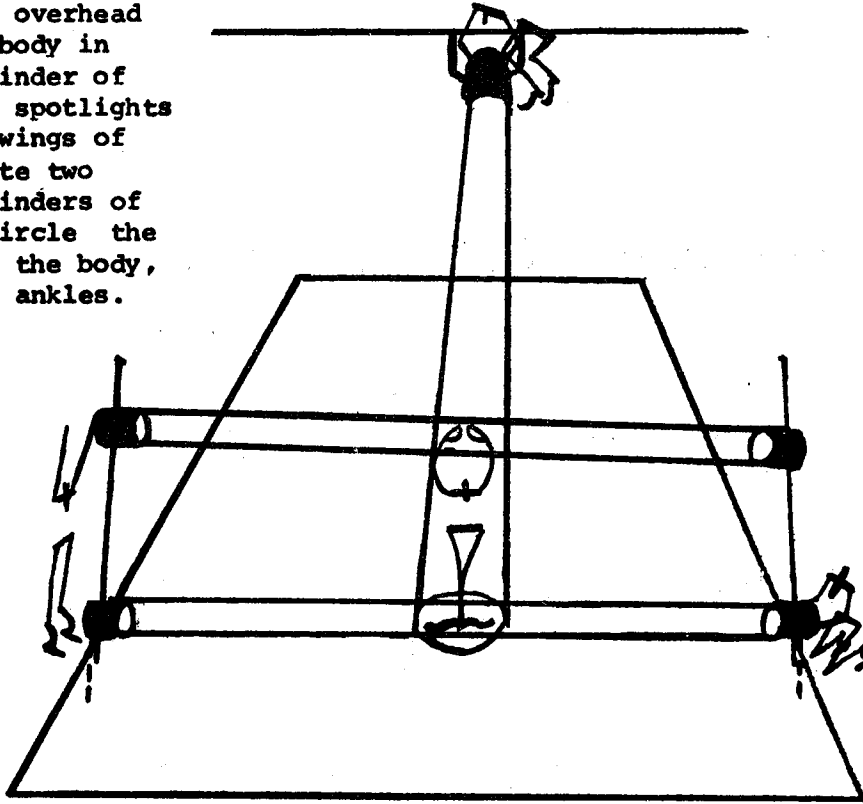

The Reader Views The Figure From The Front, As If Sitting In The Audience, Watching The Figure Move On Stage.



# THE PLANES OF THE BODY

## THE FRONTAL PLANE

1. The Frontal Plane cuts the body from side to side, reaching from the top of the head to the bottom of the feet. It cuts the body into a front and back portion.
2. The Frontal Plane cutting the body moves with the body as the body changes facing in the room. This is different than the planes cutting the room, which never move or change.
3. When the spokes of the Position Symbol project to the side of the symbol, the limbs are projecting along the body's Frontal Plane.

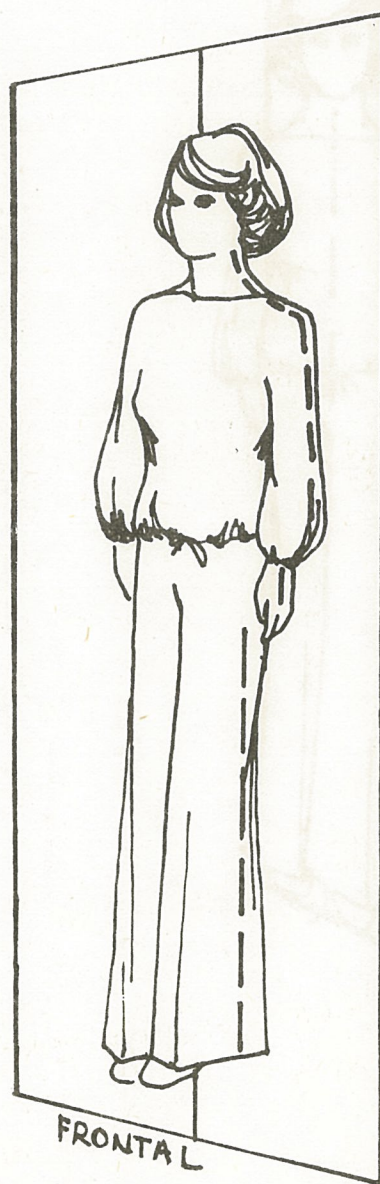
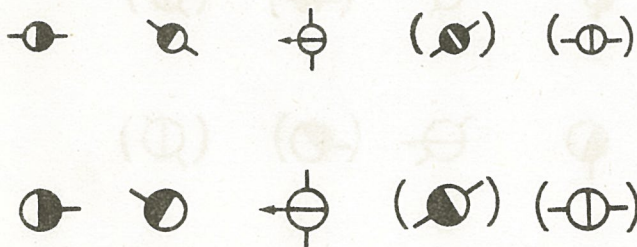

# THE DIAGONAL PLANE

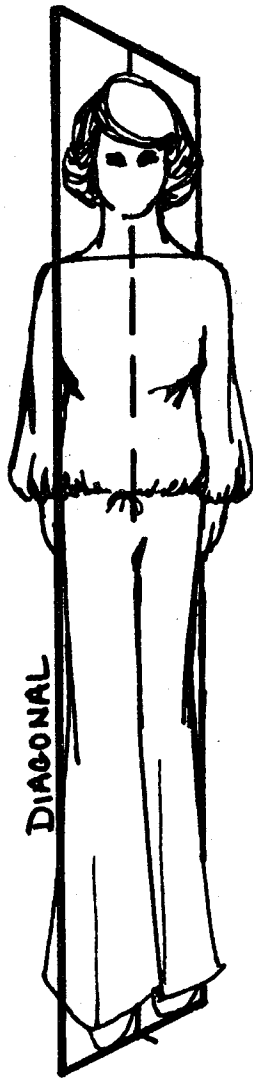

1. The Diagonal Plane cuts the body from the front corner of the body to the opposite back corner of the body, reaching from the top of the head to the bottom of the feet.

2. The Diagonal Plane cutting the body moves with the body as the body changes facing in the room. This is different than the planes cutting the room, which never move or change.

3. When the spokes of the Position Symbol project to the diagonal of the symbol, the limbs are projecting along the body's Diagonal Plane.

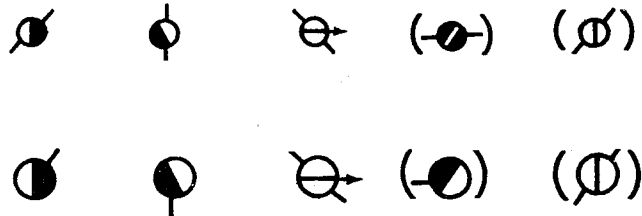



# THE DIAGONAL PLANE

1. The Diagonal Plane cuts the body from the front corner of the body to the opposite back corner of the body, reaching from the top of the head to the bottom of the feet.
2. The Diagonal Plane cutting the body moves with the body as the body changes facing in the room. This is different than the planes cutting the room, which never move or change.
3. When the spokes of the Position Symbol project to the diagonal of the symbol, the limbs are projecting along the body's Diagonal Plane.

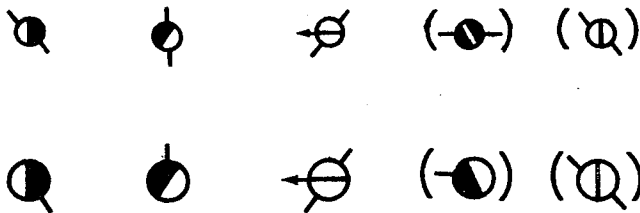
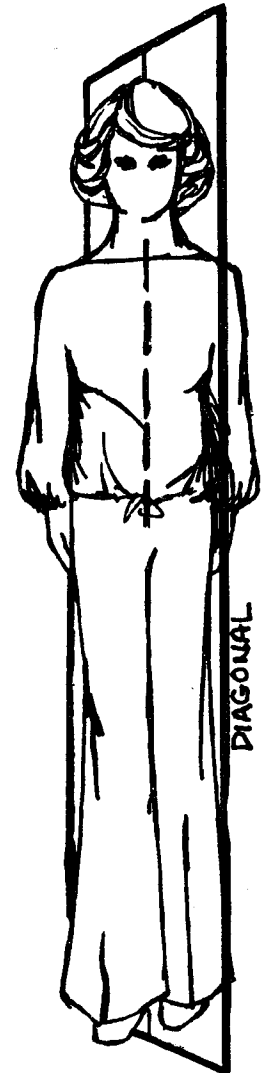

# THE SAGITTAL PLANE

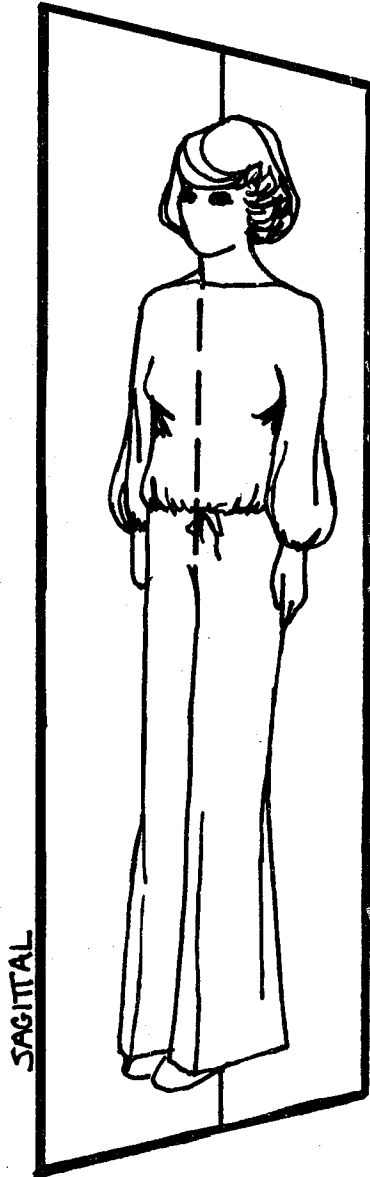

1. The Sagittal Plane cuts the body from front to back, reaching from the top of the head to the bottom of the feet. It cuts the body into a right and left portion.
2. The Sagittal Plane cutting the body moves with the body as the body changes facing in the room. This is different than the planes cutting the room, which never move or change.
3. The center line written down the middle of the Position Symbol corresponds to the Sagittal Plane of the body at all times.
4. When the spokes of the Position Symbol project at the bottom of the symbol, or at the top of the symbol, parallel with the symbol's center line, the limbs are projecting along the body's Sagittal Plane.

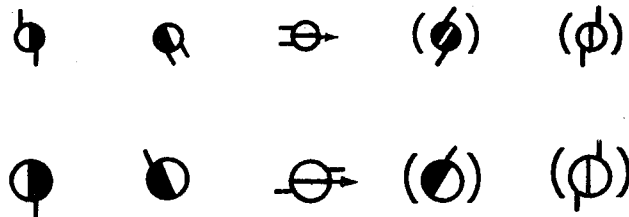

# THE TRANSVERSE PLANE

1. The Transverse Plane cuts the body through the middle. The Transverse Plane is parallel with the floor and cuts the body from all sides. The Transverse Plane dissects the body into a lower and upper portion.
2. The best view of the Transverse Plane cutting the body is from overhead. The overhead view gives the complete picture of the Transverse Plane extending in all directions.
3. All Position Symbols are seen from the overhead view. All Position Symbols, then, are viewed along the Transverse Plane. The Frontal, Diagonal, and Sagittal Planes that also dissect the body are all seen in conjunction with the Transverse Plane in Position Symbols.

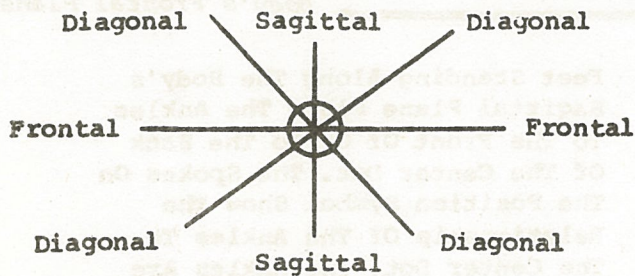
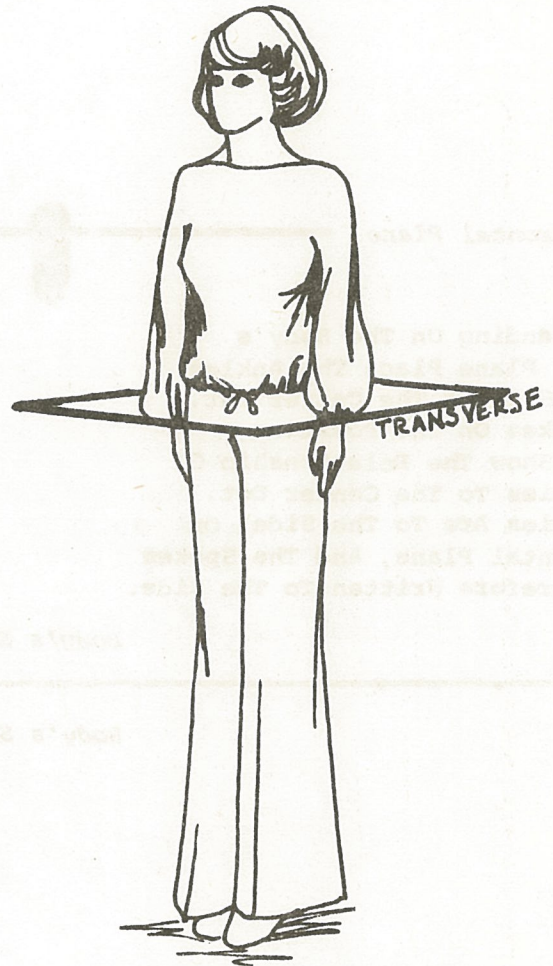

All Seen From The Transverse Plane

# THE CENTER DOT THE ANKLES

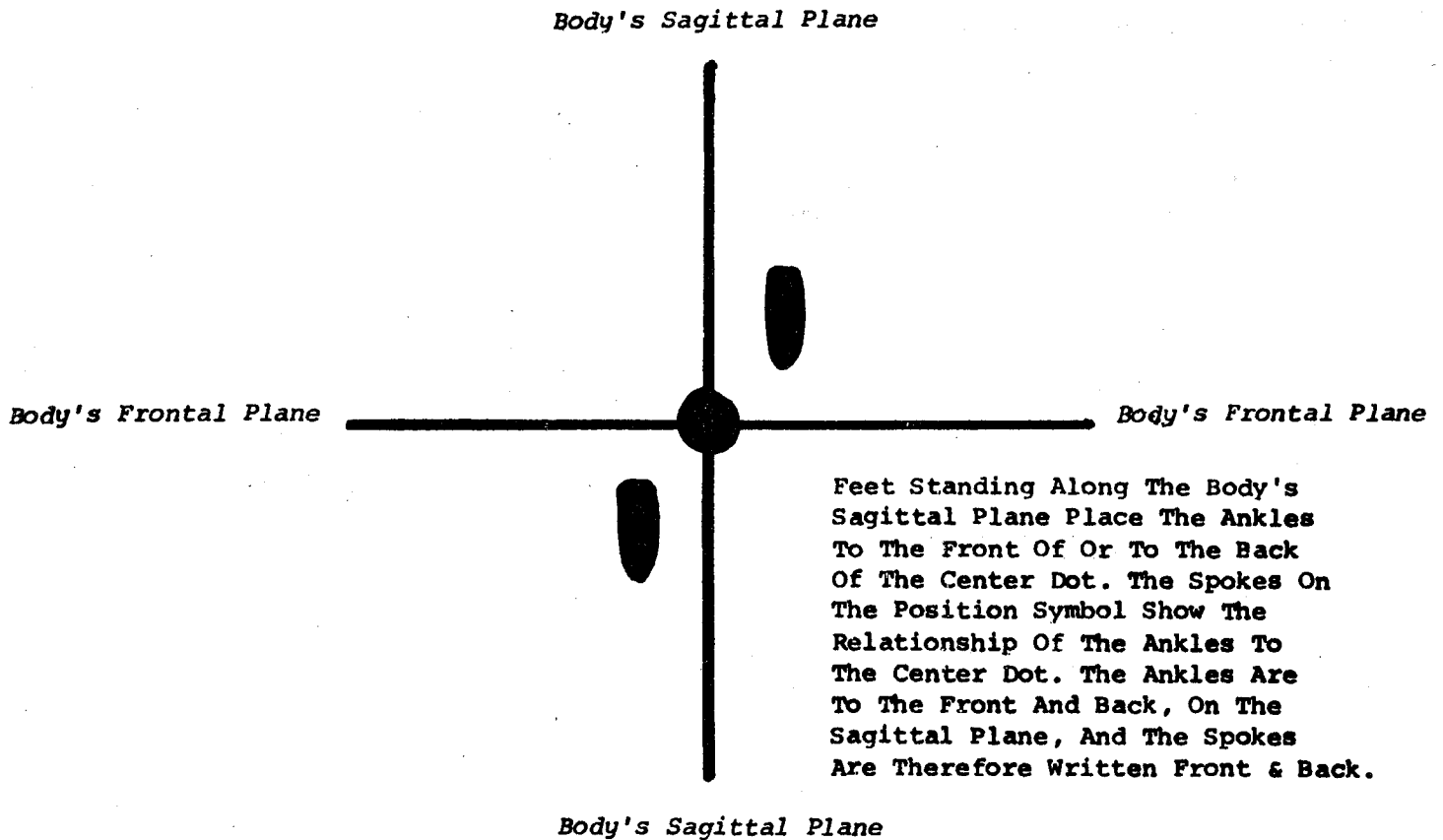
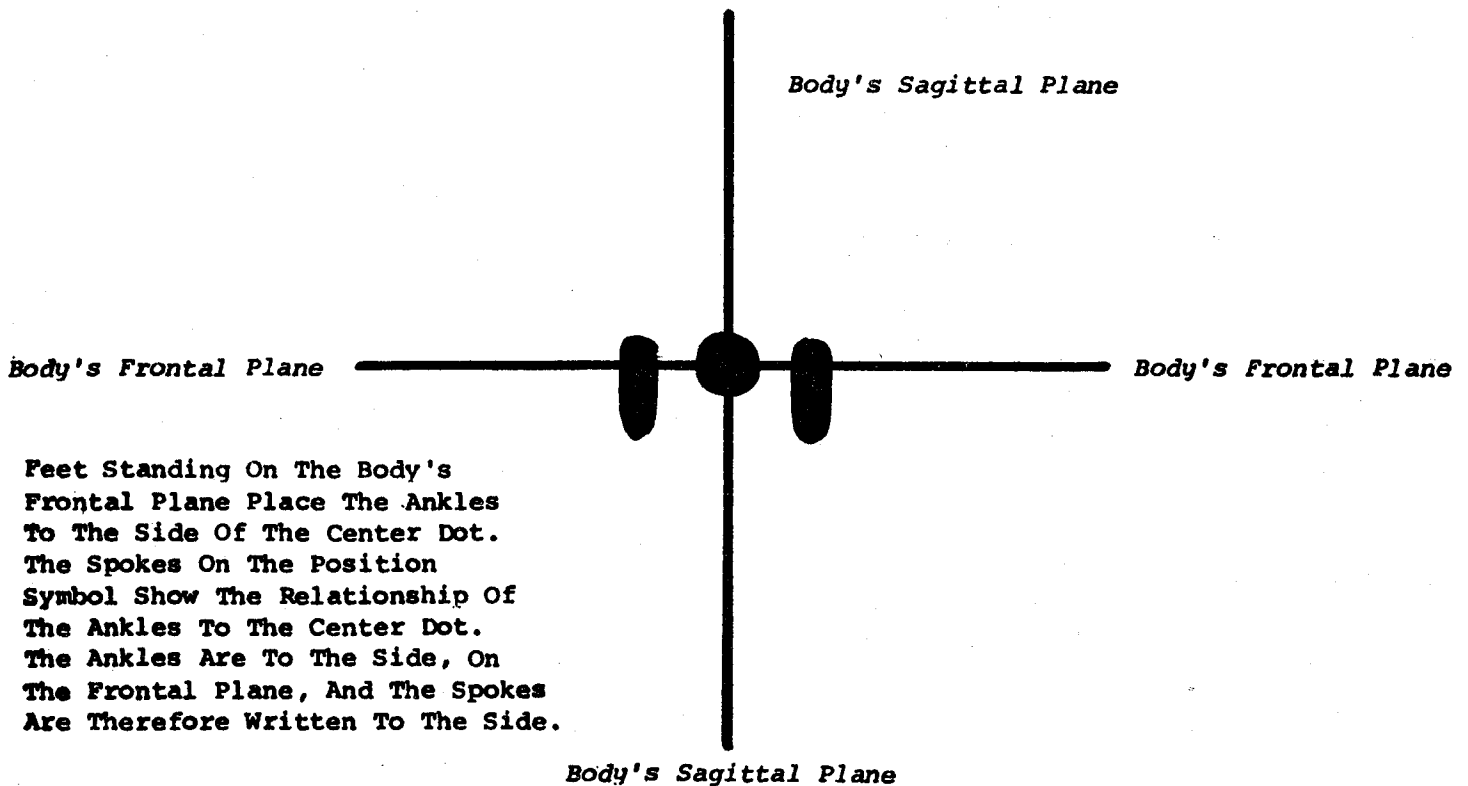

# ANKLES, SPOKES AND CENTER DOT

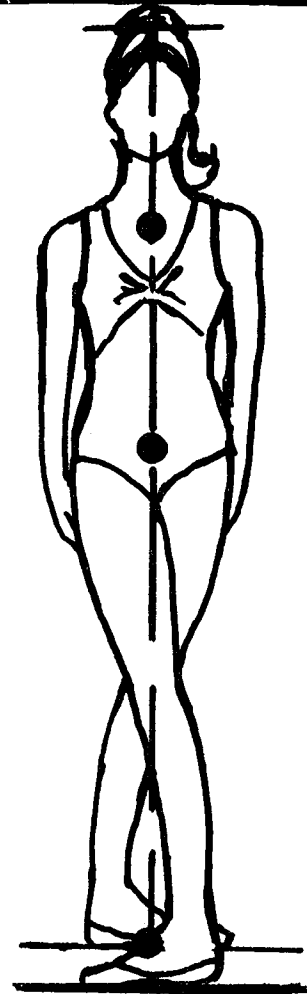
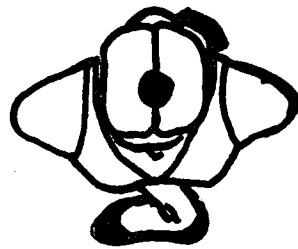
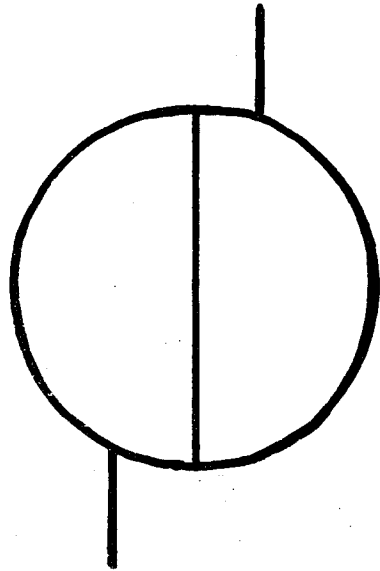
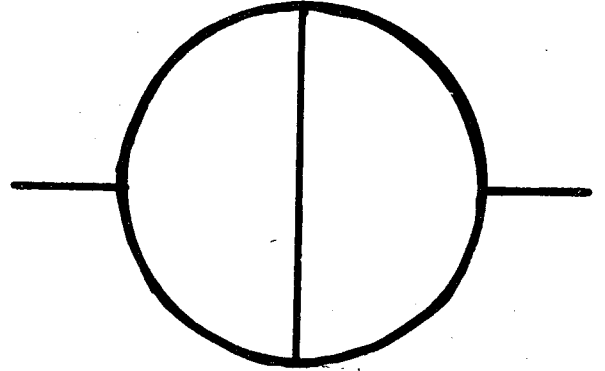
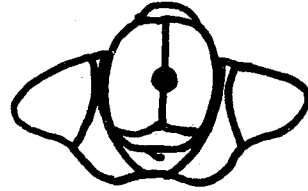
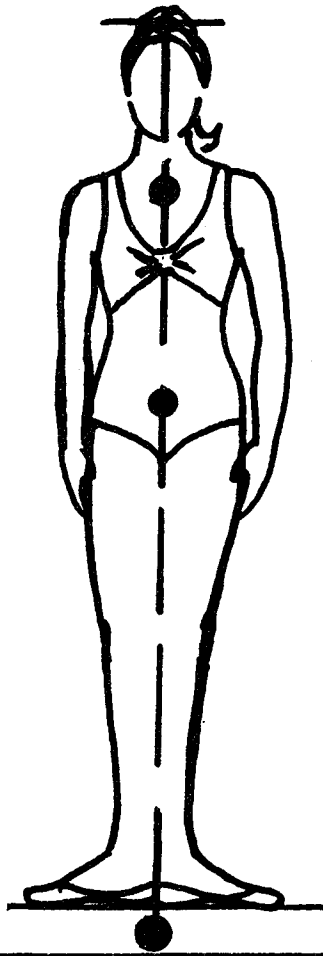

# THE CENTER DOT THE WRISTS

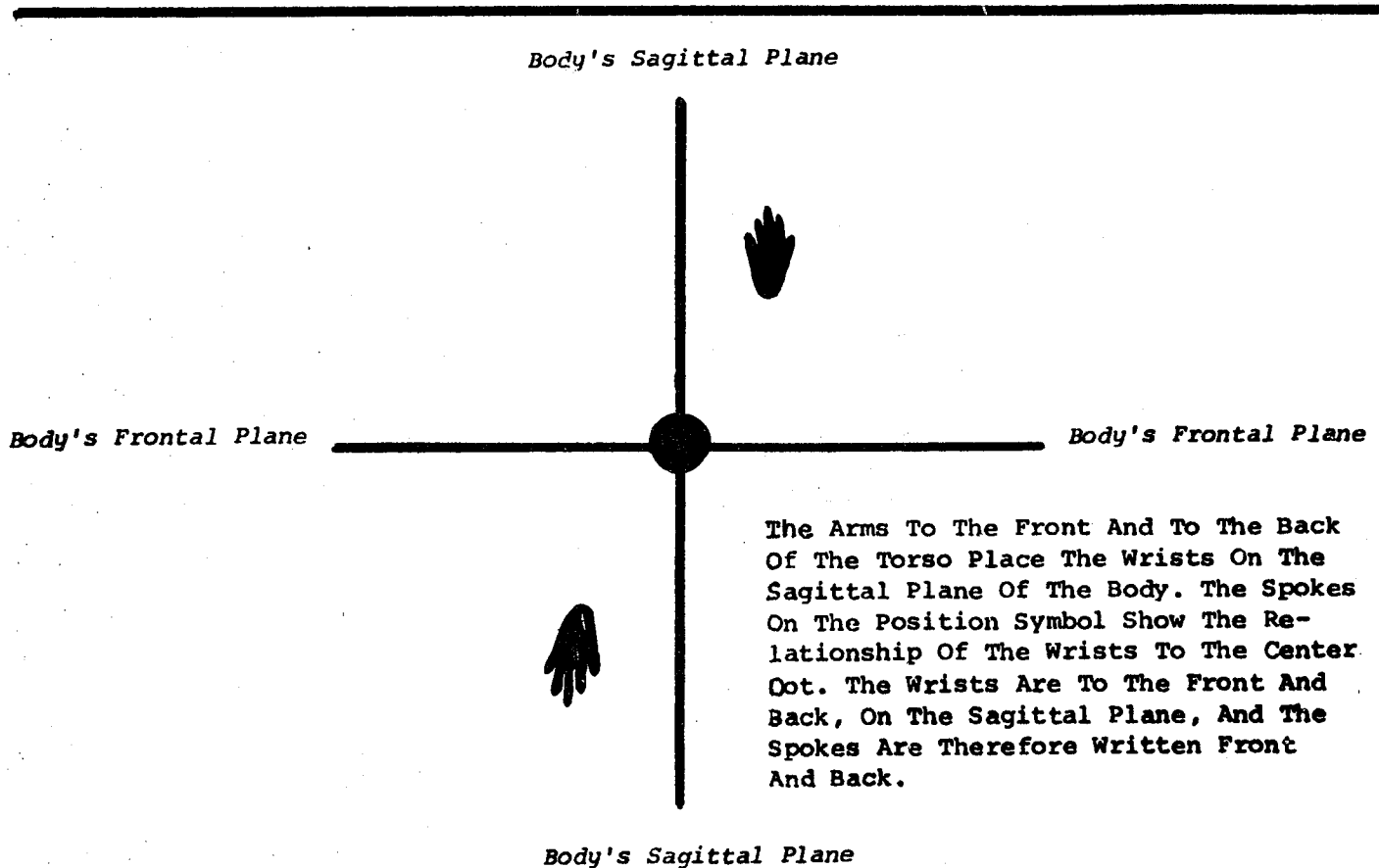
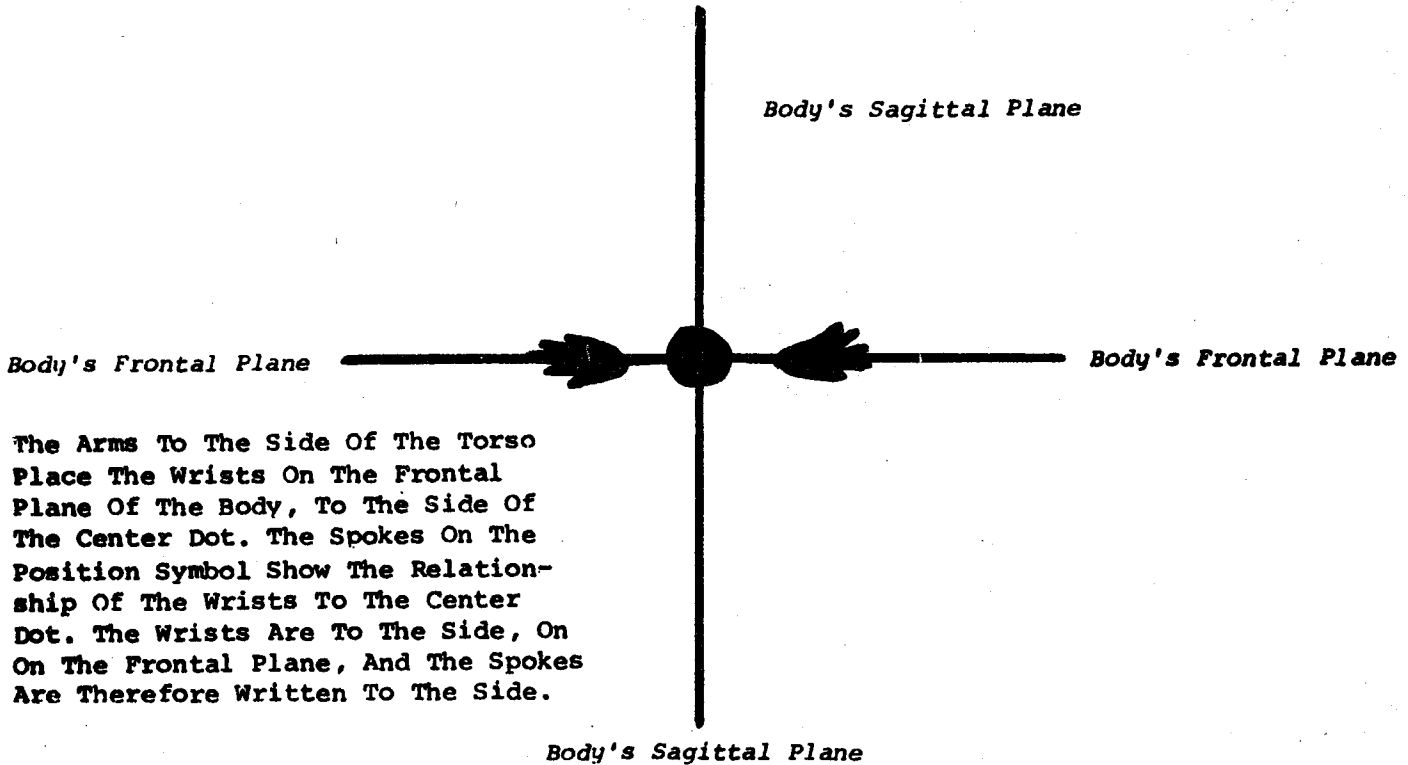



# WRISTS, SPOKES AND CENTER DOT

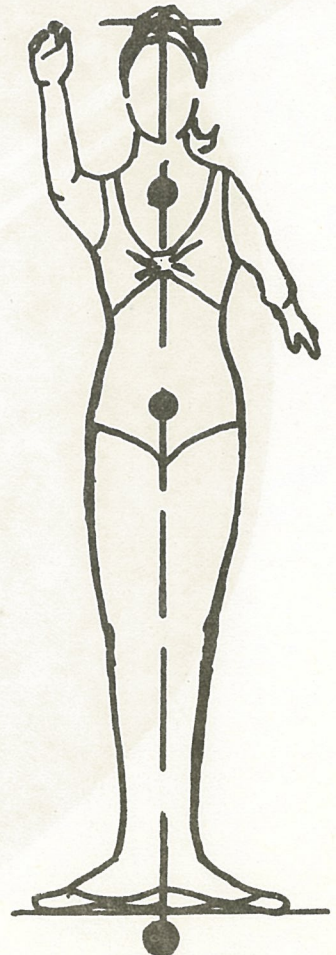
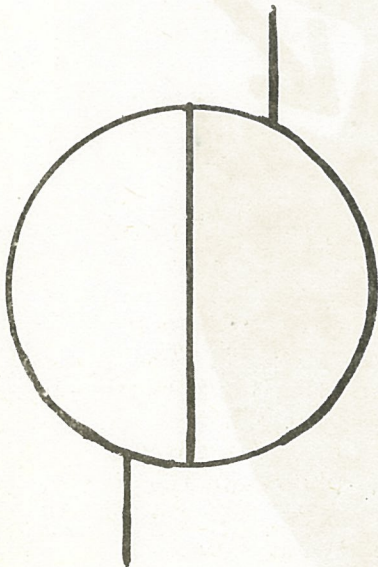
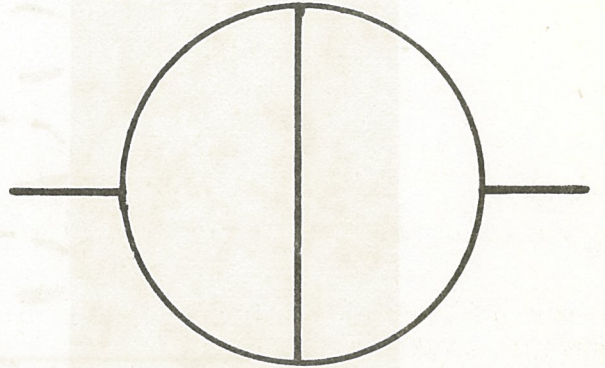
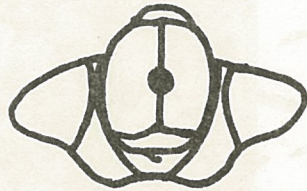
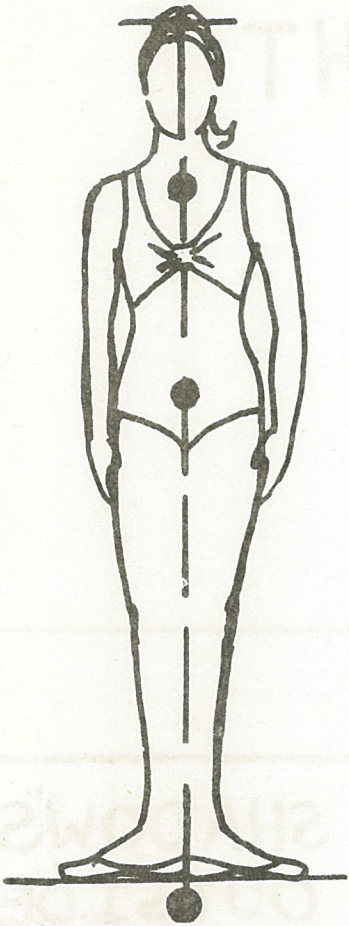



# CYLINDER OF LIGHT

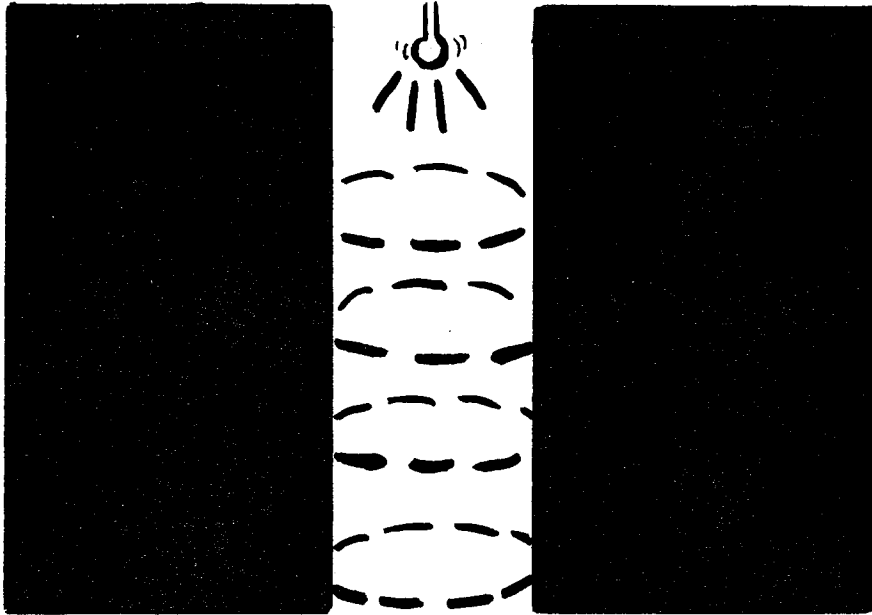

CYLINDER  
OF LIGHT

SHADOWS  
OUTSIDE  
CYLINDER

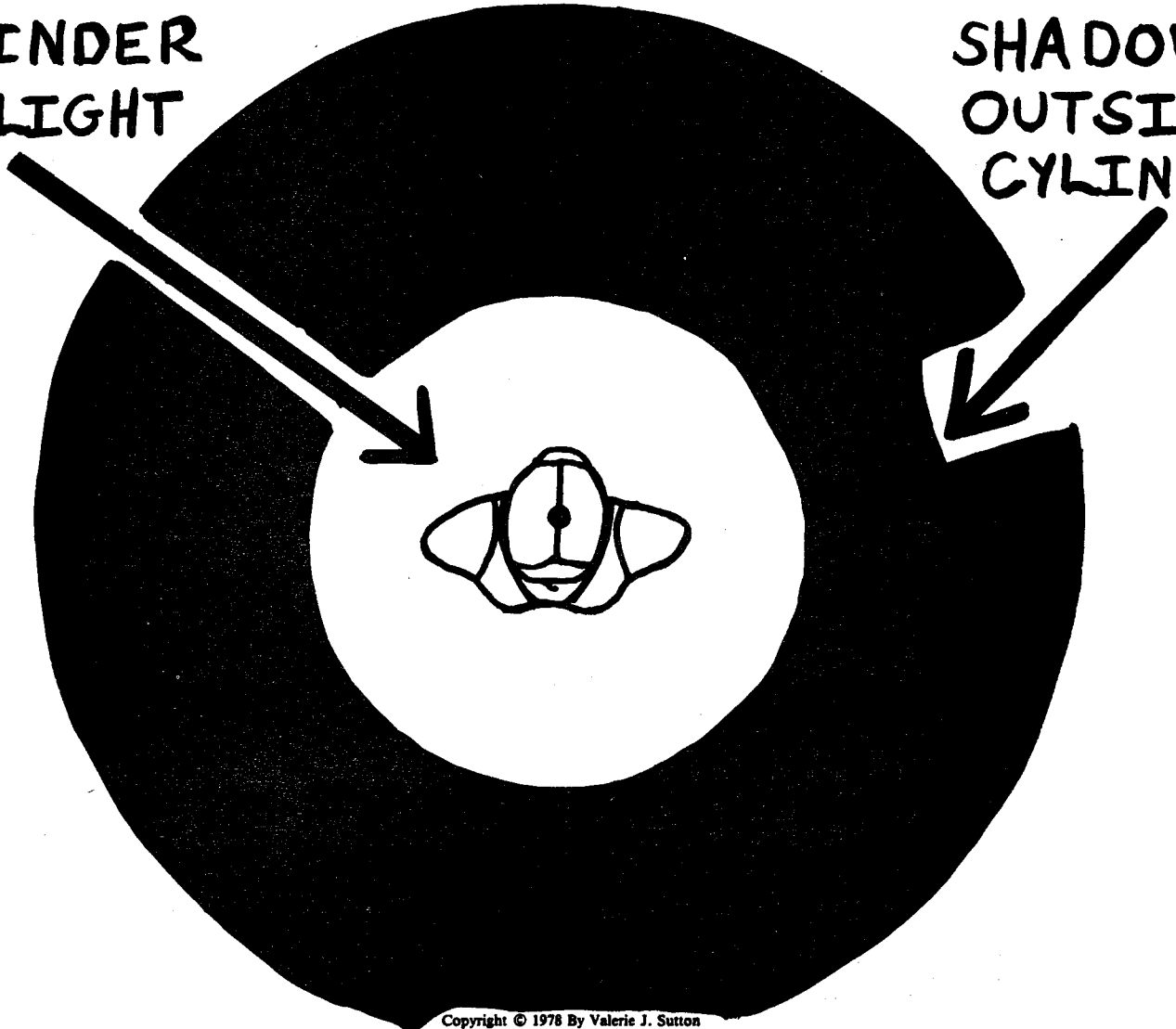

# CYLINDER AROUND CENTER

## VERTICAL CYLINDER ENCIRCLES VERTICAL CENTER LINE

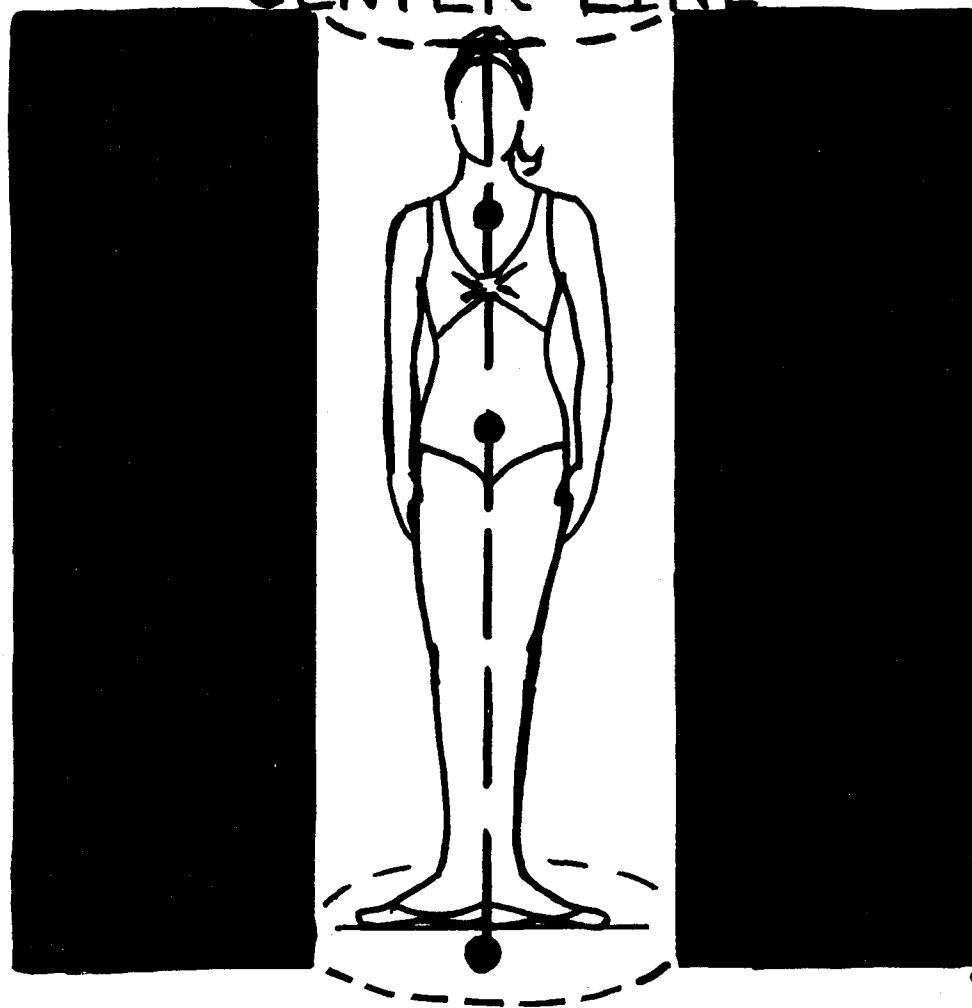

Copyright © 1978 By Valerie J. Sutton  
 ALL RIGHTS RESERVED  
 Pan American And Universal Copyrights Secured

## VERTICAL CYLINDER CREATES IN-OUT DEPTH

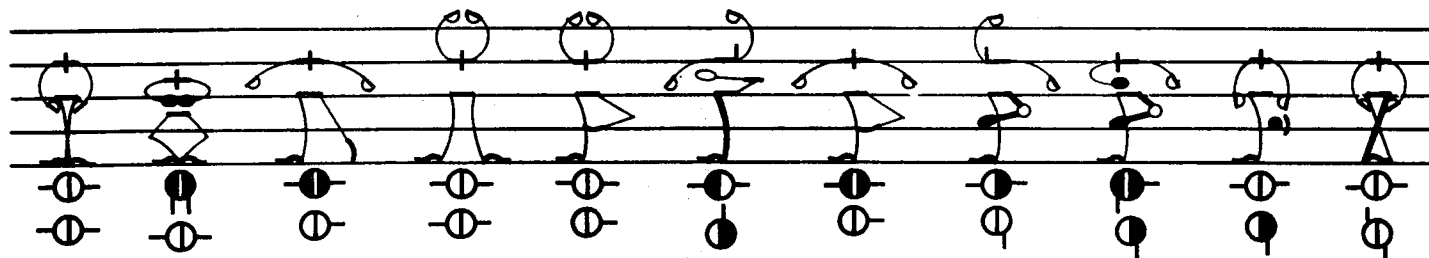

Small Position Symbols under the staff write In-Out Depth. They describe a limb close to the center of the body (inside light cylinder) or far from the center of the body (out in the shadows). They are used for legs or arms, and are placed in either row of Position Symbols under the staff.

# IN-OUT POSITION SYMBOLS

ARMS CLOSE (IN)

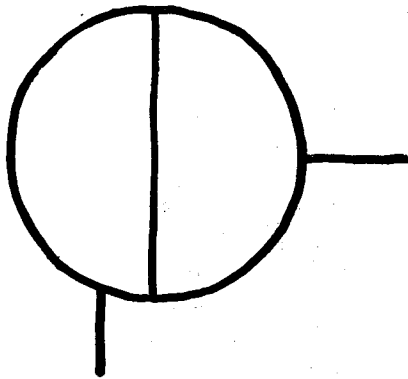

ARMS FAR (OUT)

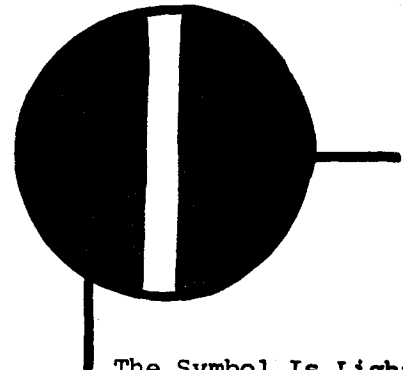

The Light Cylinder Ends At Elbow Or Knee Range (When The Arm Or Leg Is At Shoulder Or Hip Height) It Is As Wide As The Length Of The Upper Arm Or Upper Leg.

The Symbol Is Light If The Wrist Or Ankle Is Inside The Light Cylinder. The Symbol Is Dark If The Wrist Or Ankle Is Outside, In The Shadows

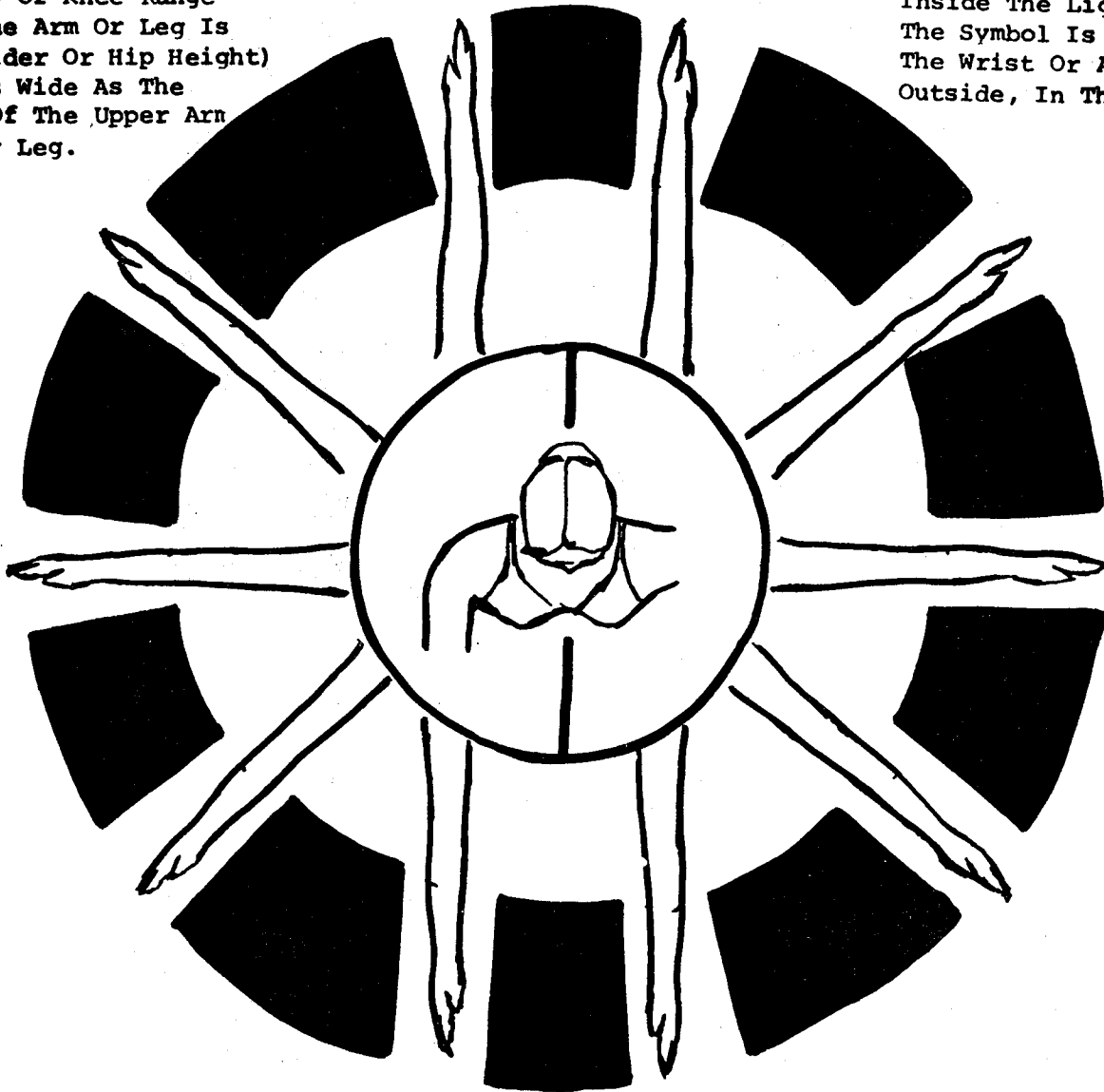

# IN-OUT POSITION SYMBOLS

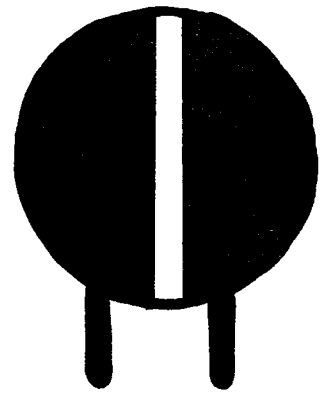
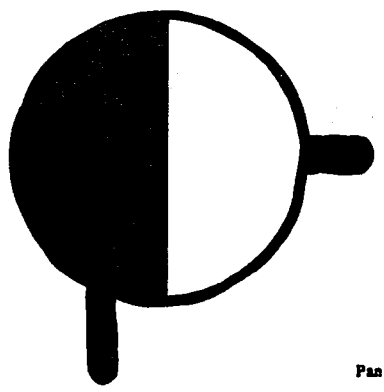
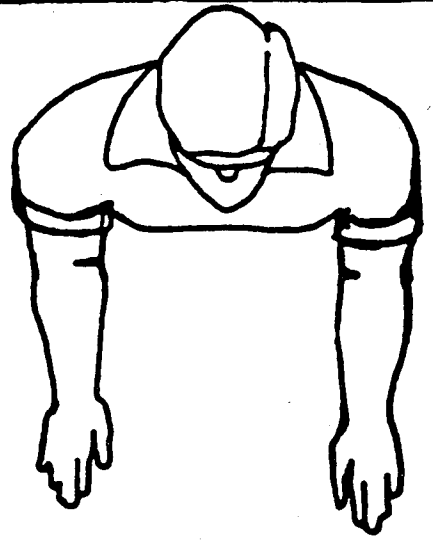
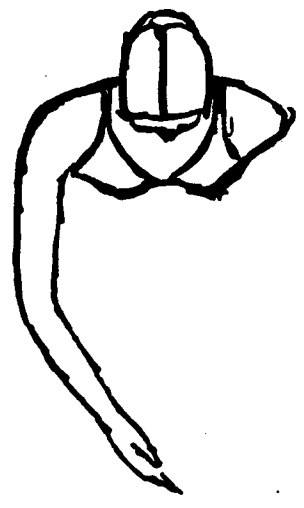
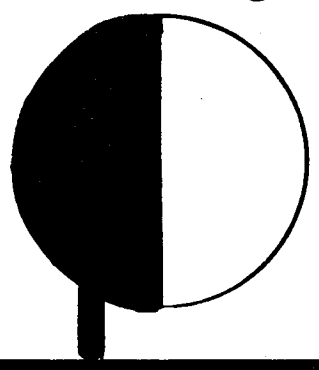
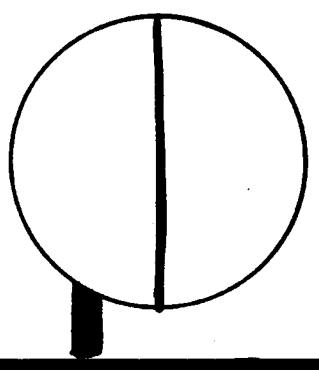
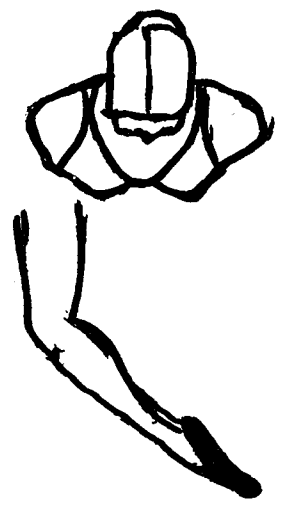
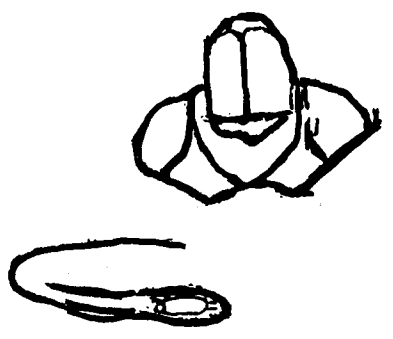

# CYLINDER OF LIGHT

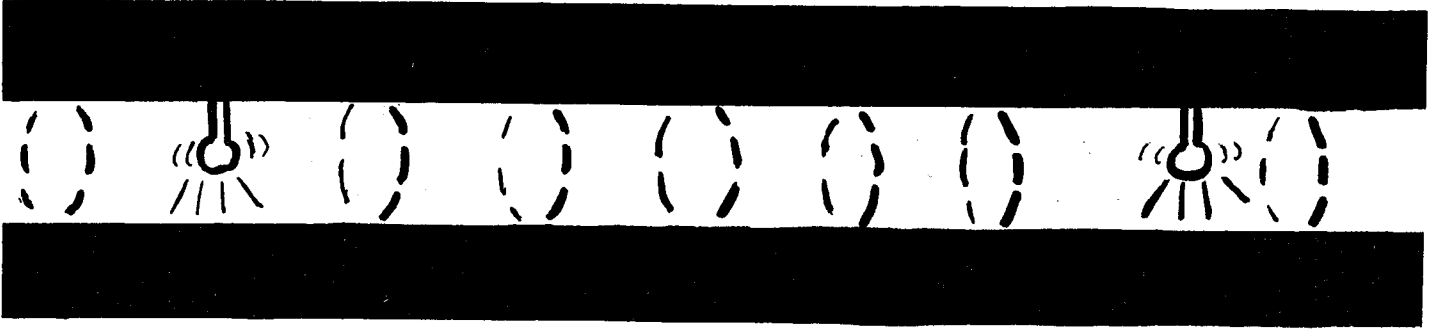

CYLINDER  
OF LIGHT

SHADOWS  
ABOVE & BELOW  
CYLINDER

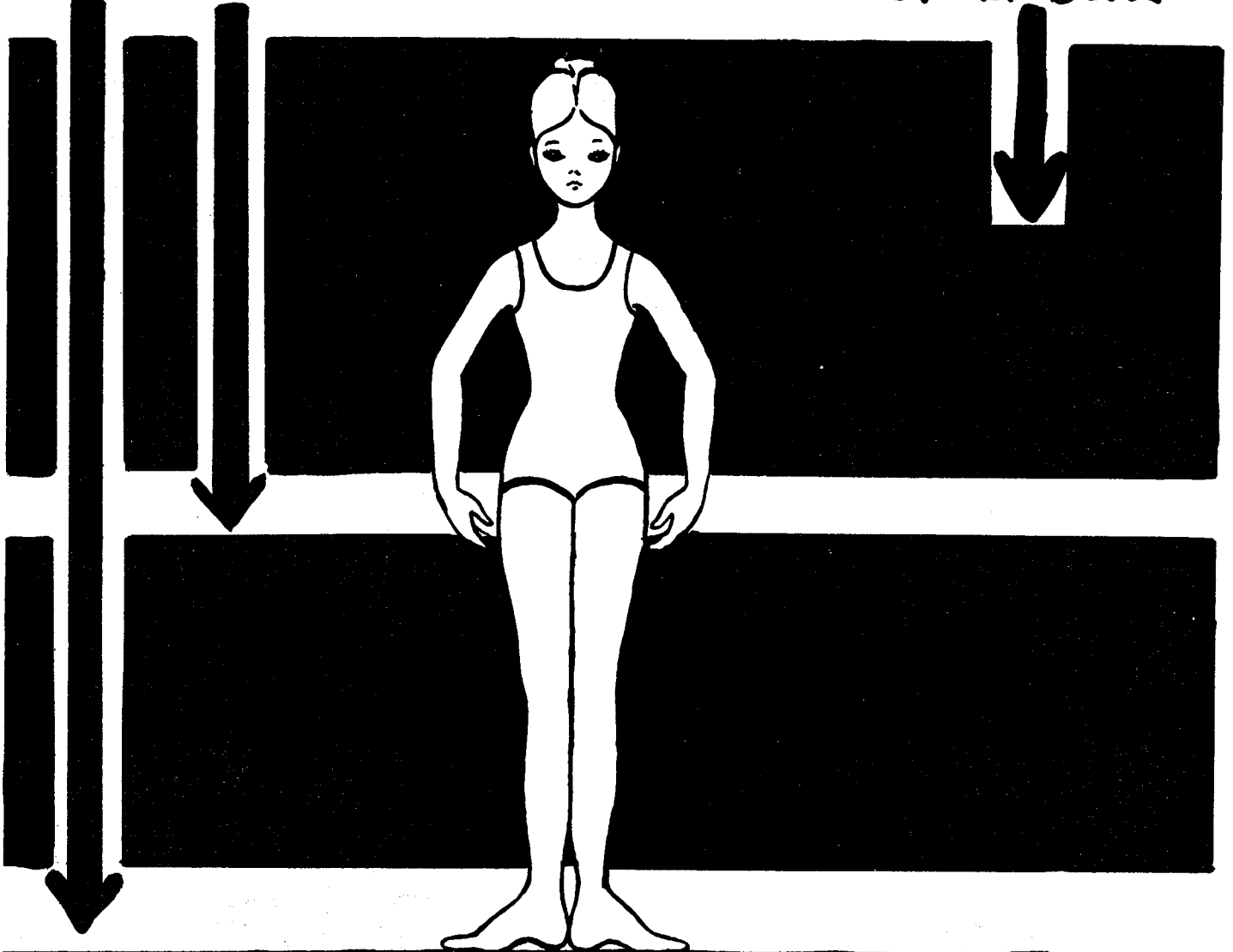

# CYLINDER AROUND EXTREMITIES

HORIZONTAL CYLINDERS ENCIRCLE  
LOWEST WRIST AND ANKLE

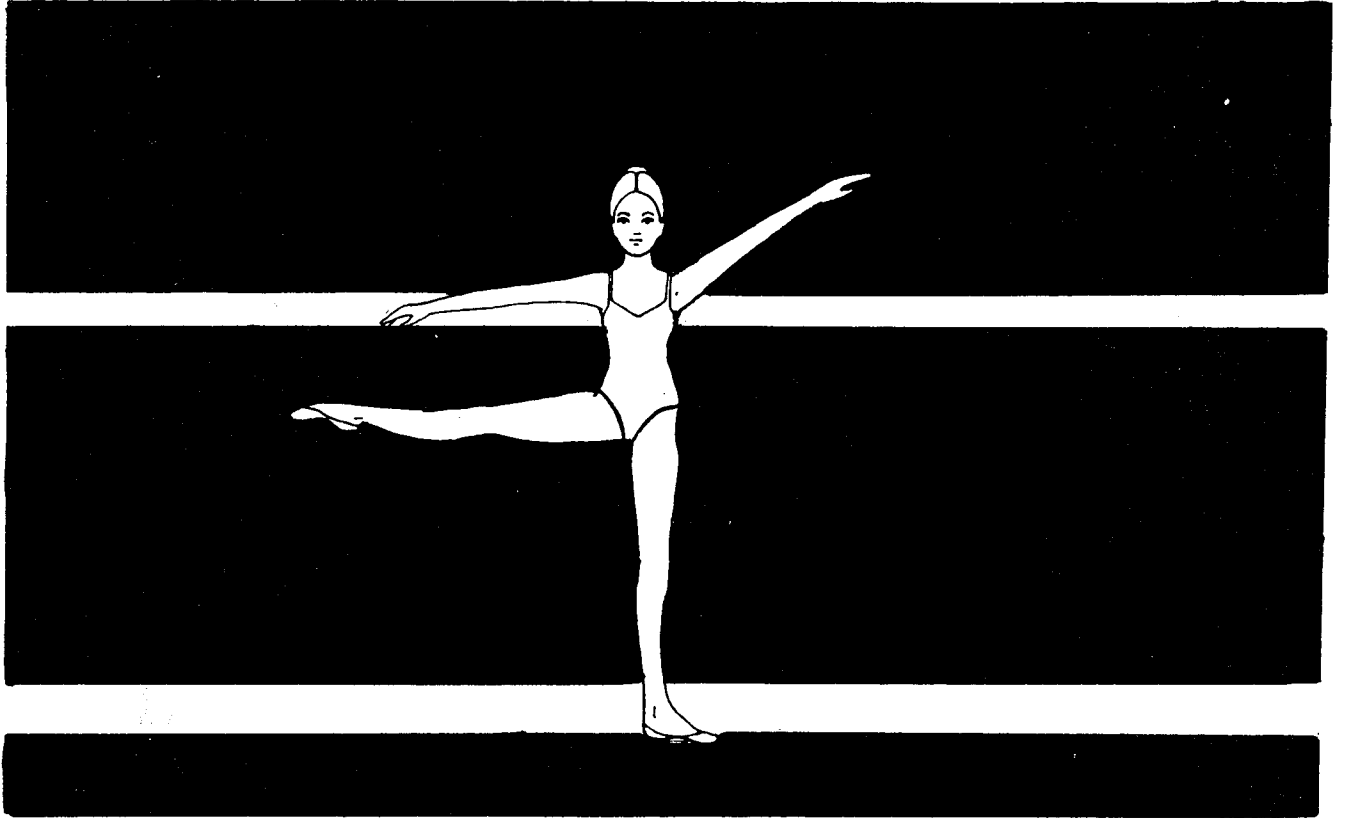

HORIZONTAL CYLINDERS  
CREATE UP-DOWN DEPTH

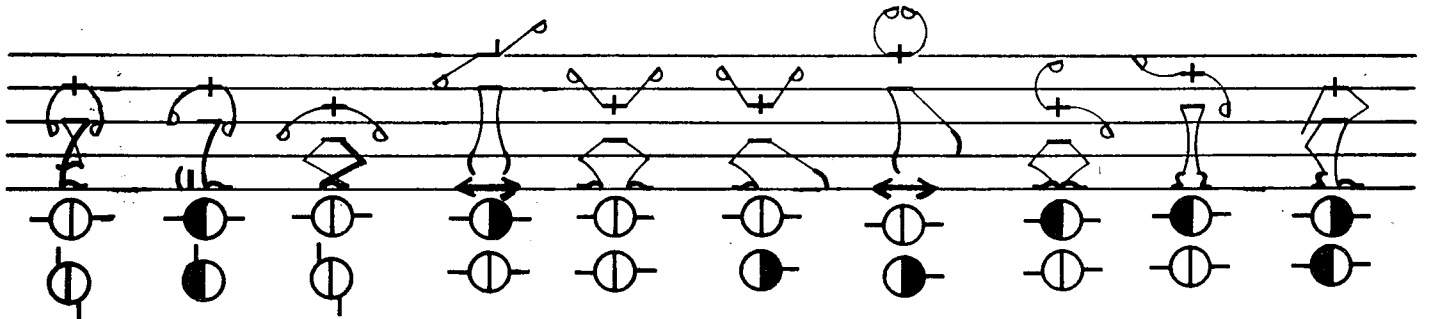

Large Position Symbols under the staff write Up-Down Depth. They describe a limb higher than the other limb (up in the shadows) or lower than the other limb (down in the light cylinder). When both limbs are at an equal level then both limbs are in the light cylinder. They are used for legs or arms, and are placed in either row of Position Symbols under the staff.

# UP-DOWN POSITION SYMBOLS

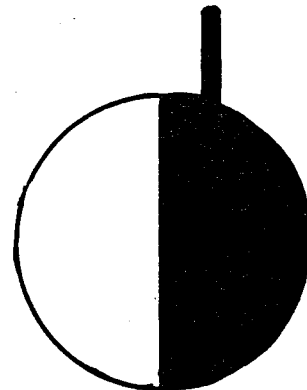
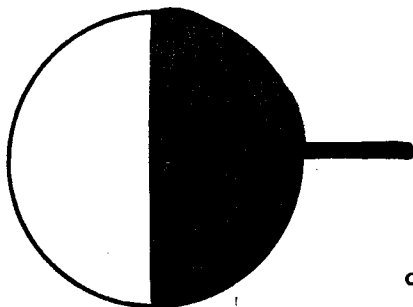
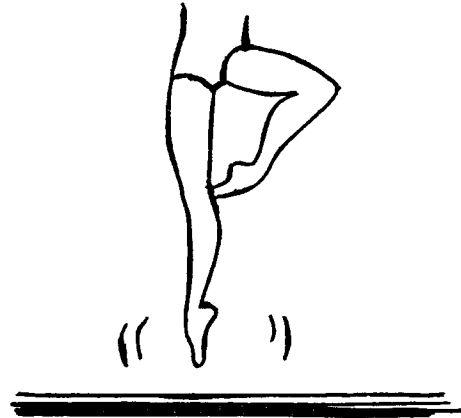
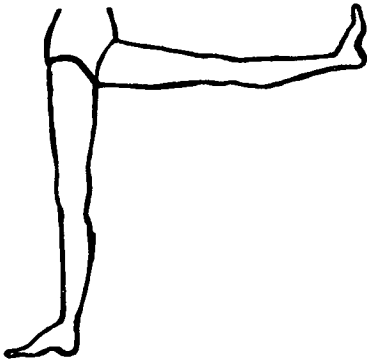
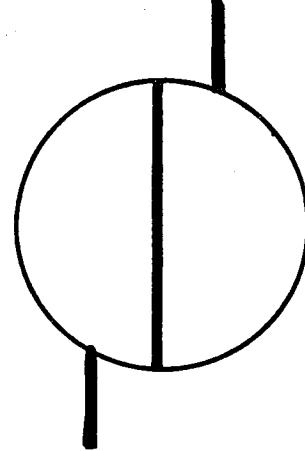
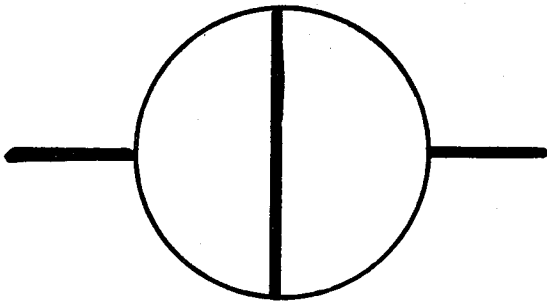
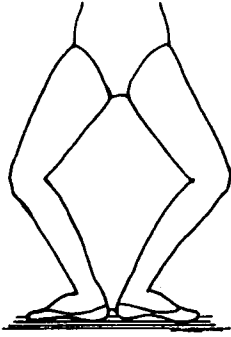



# UP-DOWN POSITION SYMBOLS

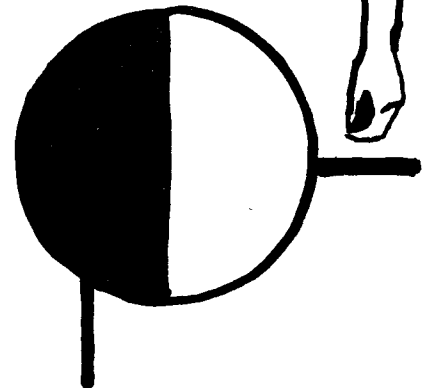
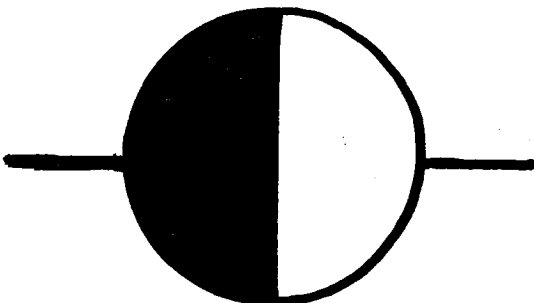
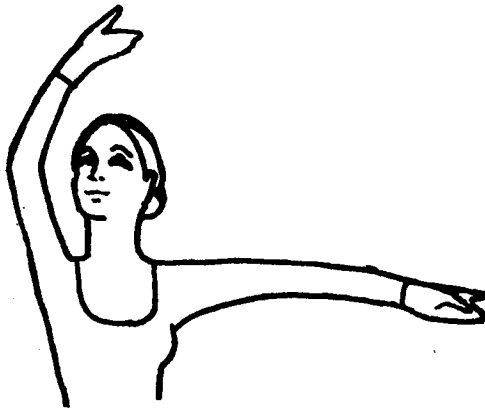
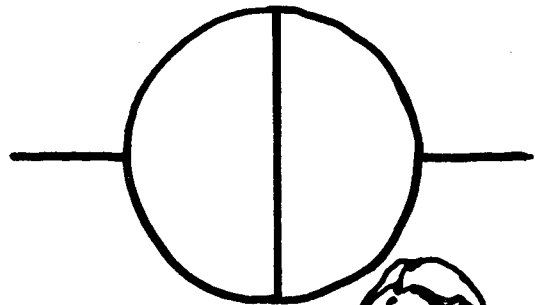
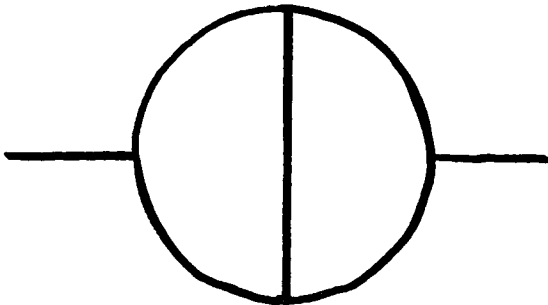
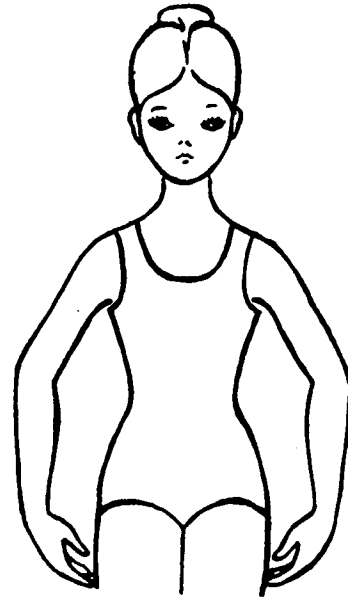
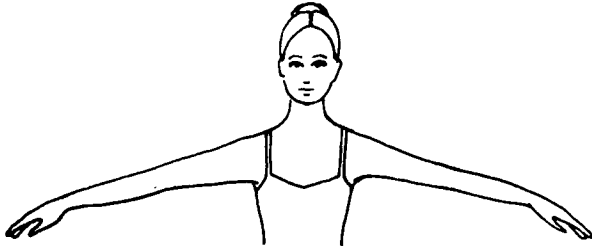

# THE SAGITTAL CENTER

FACING  
FRONT WALL

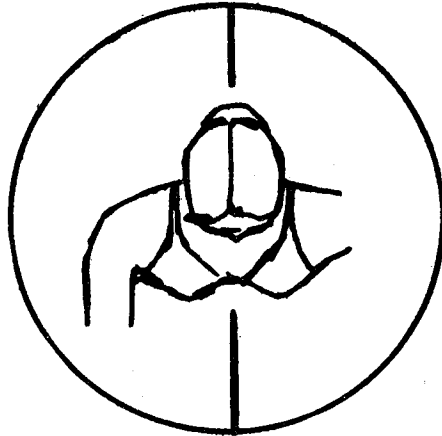

FACING  
READER

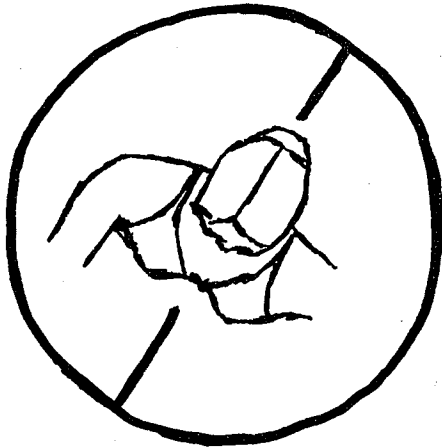

FACING  
FRONT  
CORNERS

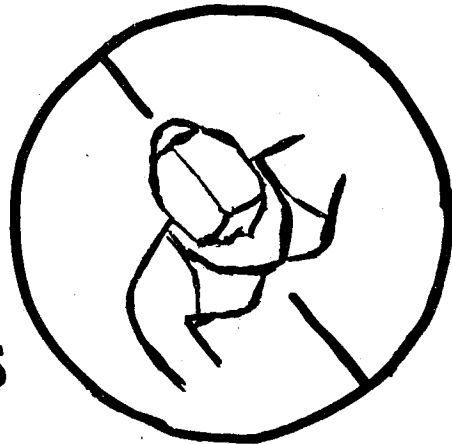

FACING SIDE WALLS

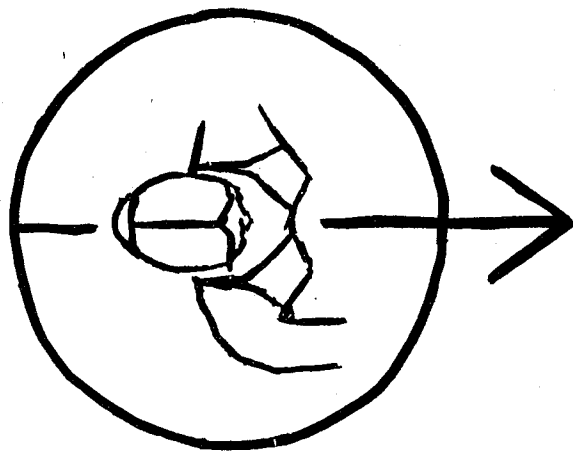
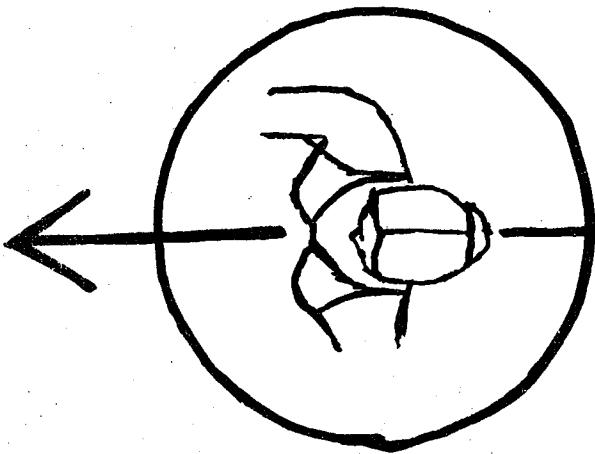

# THE SAGITTAL CENTER

## FACING BACK CORNERS

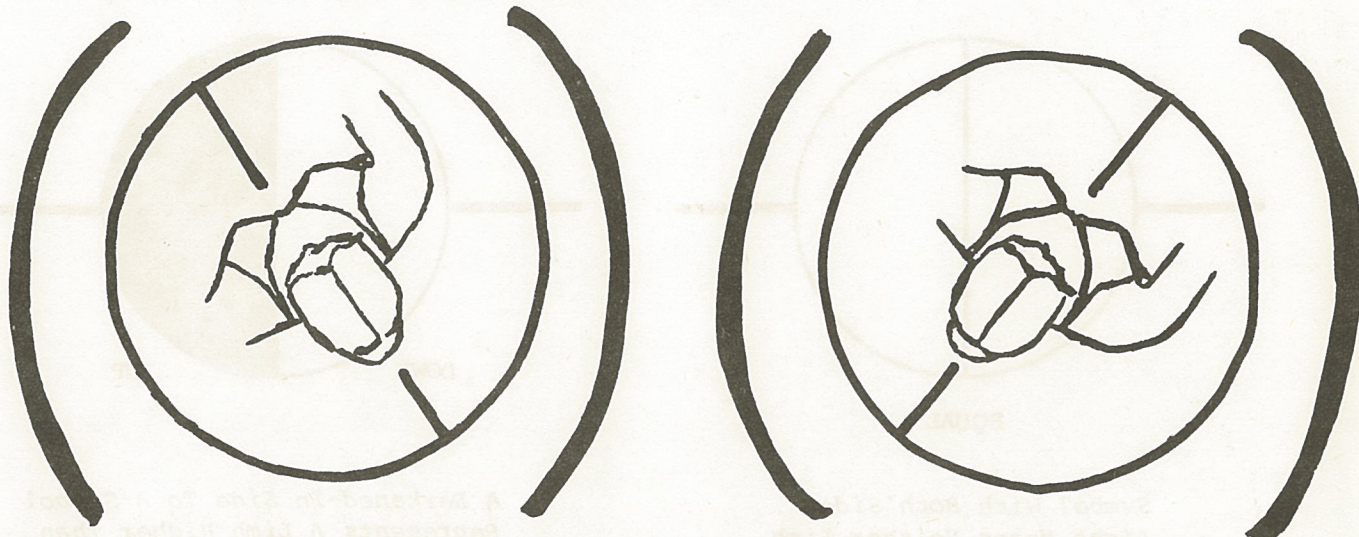

---

## FACING BACK WALL

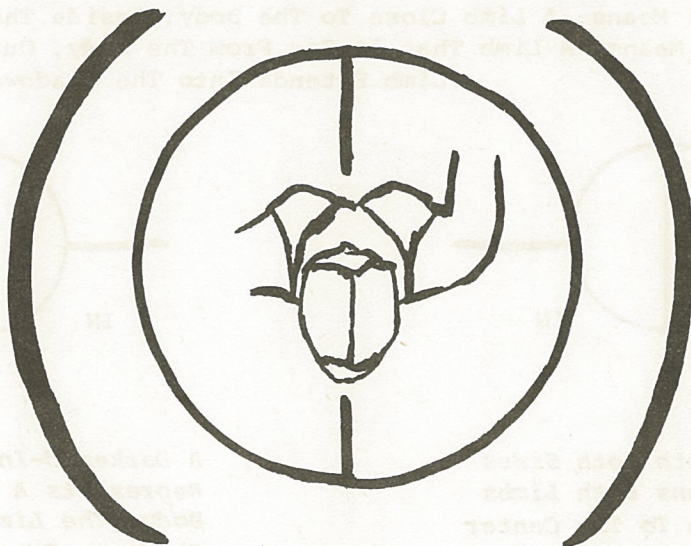

THE LARGE POSITION SYMBOLS

Name: The Up-Down Position Symbols

Purpose: Write Depth Up And Down

Placement: In Either Row Of Position Symbols Under The Staff

Light In The Symbol Means: A Lower Limb, Or A Limb That Is Not Higher Than The Other

Dark In The Symbol Means: A Higher Limb, A Limb That Is Higher Than The Other

(Creates More Shadows Than A Lower Limb)

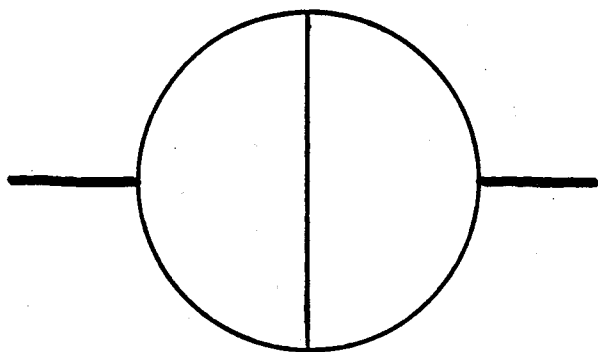

EQUAL

*Symbol With Both Sides  
Light Means Neither Limb  
Is Higher Than The Other*

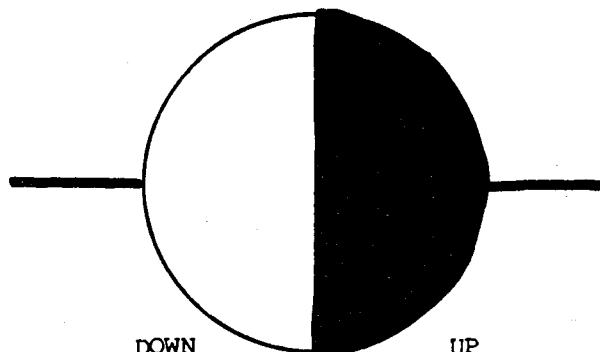

DOWN

UP

*A Darkened-In Side To A Symbol  
Represents A Limb Higher Than  
The Other Limb (Makes More Of  
A Shadow Than The Other)*

THE SMALL POSITION SYMBOLS

Name: The In-Out Position Symbols

Purpose: Write Depth In And Out From Body

Placement: In Either Row Of Position Symbols Under The Staff

Light In The Symbol Means: A Limb Close To The Body, Inside The Cylinder Of Light

Dark In The Symbol Means: A Limb That Is Far From The Body, Outside The Cylinder

(Limb Extends Into The Shadows Outside Cylinder)

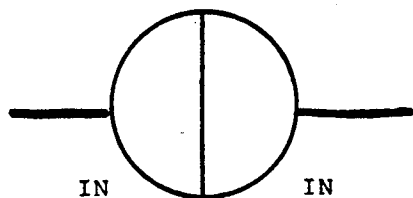

IN

IN

*Symbol With Both Sides  
Light Means Both Limbs  
Are Close To The Center  
(Inside Light Cylinder)*

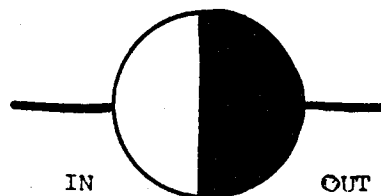





IN



OUT

*A Darkened-In Side To A Symbol  
Represents A Limb Far From The  
Body (The Limb Extends Into The  
Shadows, Outside Of The Cylinder  
Of Light)*

RULES FOR POSITION SYMBOLS

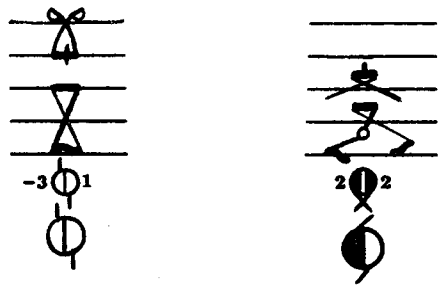
1. When all of the planes that cut the body intersect the body, they meet in the center of the body. We call this central point the CENTER DOT.
2. The CENTER DOT is in line with the body's center of gravity. From the CENTER DOT the line of gravity falls in a straight line to the floor, creating another dot on the floor. The two CENTER DOTS, one in the middle of the body, and the other directly below on the floor, are connected by an imaginary vertical line.
3. The CENTER DOT of the Position Symbol for the lower body is located in the center of the hips (the groin). The body planes intersect at the hip area. An imaginary vertical line falls straight down from this CENTER DOT, creating another CENTER DOT on the floor.
4. The CENTER DOT of the Position Symbol for the upper body is located in the center of the shoulders (between the two collar bones). The body planes intersect at the shoulder area. The imaginary vertical line falls straight down from this CENTER DOT, creating another CENTER DOT on the floor. When the body stands erect, the upper and lower body's CENTER DOT on the floor is the same (one is on top of the other).
5. The Direction Spokes of the Position Symbol show the relationship of the ankle of the leg or the wrist of the arm with the CENTER DOT.
6. If the ankle or wrists are in front of the CENTER DOT, then the spokes of the Position Symbol project at the bottom of the symbol: 
7. If the ankle or wrists are to the corner of the CENTER DOT, then the spokes of the Position Symbol project to the diagonal of the symbol: 
8. If the ankle or wrists are to the side of the CENTER DOT, then the spokes of the Position Symbol project to the side of the symbol: 
9. If the ankle or wrists are to the back of the CENTER DOT, then the spokes of the Position Symbol project to the top of the symbol: 
10. If the ankle or wrist is directly on top of the CENTER DOT, then the ankle or wrist has no direction because it is directly center. The ankle or wrist of the limb can therefore have no Direction Spoke. Single standing legs, legs directly under the body (on top of the CENTER DOT) while jumping, and wrists resting on top of the center of the head are the three common examples of Position Symbols with no Direction Spoke on one side: 
11. The Direction Spokes of the Position Symbols show the relationship of the extremities of the limbs with the center of the body - the CENTER DOT.
12. If the ankle of the leg or the wrist of the arm cross over the CENTER DOT so that the entire ankle or wrist is on the other side of the center of the body, then the Direction Spoke of the Position Symbol will cross over and slant, crossing the center line of the symbol. Fifth position in classical ballet is considered to have the ankles to the front and back of the CENTER DOT, but any position more crossed than fifth position is crossing over the center and has slanted Direction Spokes.



13. If the limb crosses in front of the body while placing the ankle or wrist on the other side of the CENTER DOT, then the Direction Spokes slant at the bottom of the symbol: 
14. If the limb crosses in back of the body while placing the ankle or wrist on the other side of the CENTER DOT, then the Direction Spokes slant at the top of the symbol: 
15. In the rare case that the limb crosses underneath or over the body while placing the ankle or wrist on the other side of the CENTER DOT, then the Direction Spokes do not slant. Both spokes appear on one side of the Position Symbol: 
16. The dark and light in the Up-Down Position Symbols states the relationship of one limb with the level of the other limb. An imaginary horizontal line is drawn under the lowest ankle or wrist. The limbs touching this imaginary horizontal line at the ankle or wrist will have a corresponding light side to their Position Symbol. The limbs not touching this imaginary horizontal line at the ankle or wrist will have a dark side to their Position Symbol. There always has to be one light side to an Up-Down Position Symbol since the imaginary horizontal line is drawn under the lowest limb in every position, whether on or off the floor:

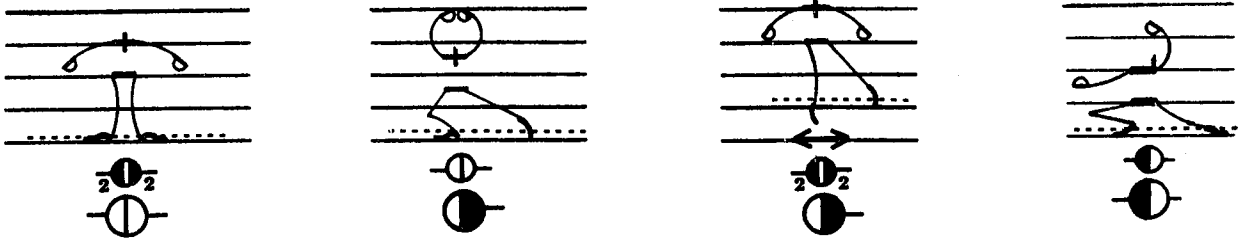

17. The dark and light in the In-Out Position Symbols states the relationship of the wrist or ankle with the CENTER DOT of the body. Whether the wrist or ankle is close to the CENTER DOT or far from the CENTER DOT is written by light and dark.
18. When the hips and shoulders are in line with each other, the shoulders parallel with the hips, the Position Symbols for the upper and lower body have the same center line. The Sagittal Plane of the body cuts both symbols at the same angle.

When the upper body twists, the Sagittal Plane that cuts the upper body must twist accordingly. The center line of the Position Symbol for the upper body therefore moves with the shoulders, slanting in a new direction. The lower body has not moved, and the Sagittal Plane that cuts the the lower body remains in the same direction as before the twist. The Sagittal Planes of the upper and lower body are now cutting the upper and lower body in two different directions. The center lines of the two Position Symbols slant at different angles. This is an excellent double check on twisting of the torso and change of direction for one half of the body.

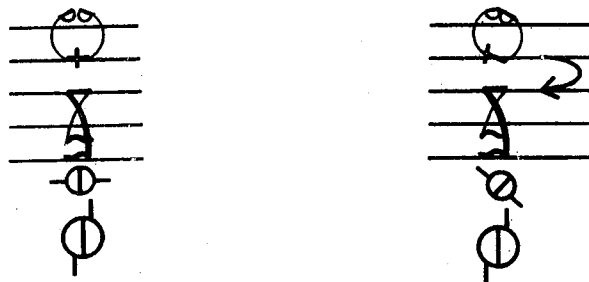

Shoulders & Hips Facing Same Direction

Shoulders & Hips Facing Different Directions



19. The first row of Position Symbols underneath the Foot Line of the Movement Staff represents the overhead view of the arms and shoulders (upper body). The second row of Position Symbols underneath the Foot Line of the Movement Staff represents the overhead view of the legs and hips (lower body). This rule never changes - the first row is always for the arms, and the second row is always for the legs. Usually the small In-Out Position Symbol is placed in the row for the arms and the larger Up-Down Position Symbol is written in the row for the legs:

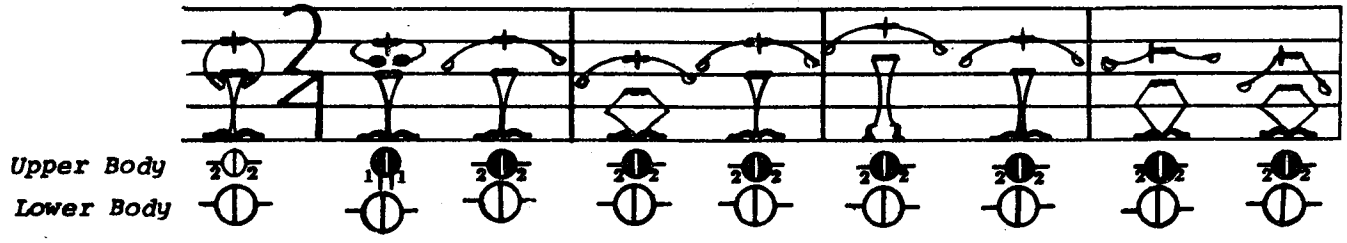

20. In the rare occasion that it is difficult to see the in-out depth with the leg, it is possible to place the In-Out Position Symbol in the second row of Position Symbols under the Staff, indicating the in-out depth with the legs:

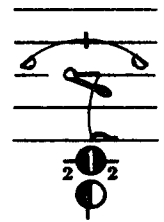

21. In the rare occasion that it is difficult to see the up-down depth with the arms, it is possible to place the Up-Down Position Symbol in the first row of Position Symbols under the Staff, indicating the up-down depth with the arms:

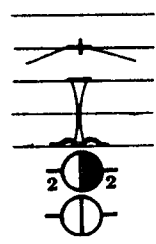

22. Although it is possible to have four Position Symbols under one stick figure, one Up-Down and one In-Out for the arms, and one Up-Down and one In-Out for the legs, it is strongly advised to not use four symbols at once. Not only is it confusing for the reader, but it is not necessary to have so many double checks for one figure. Place the In-Out or Up-Down in either row, but only place one at a time.

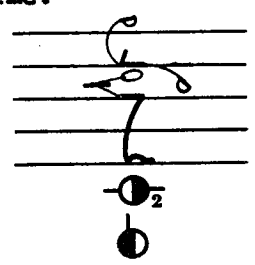

Correct Amount of Symbols

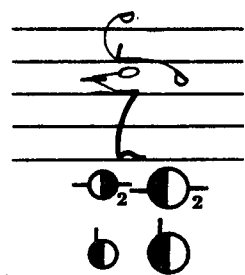

Too Many Symbols



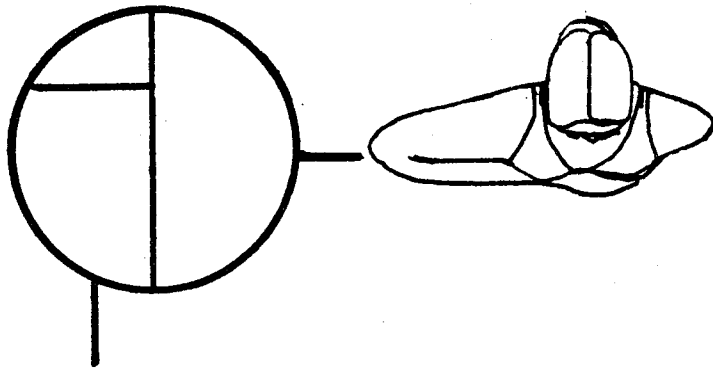

DEGREE ONE  
*Touching Torso, In Close Range*

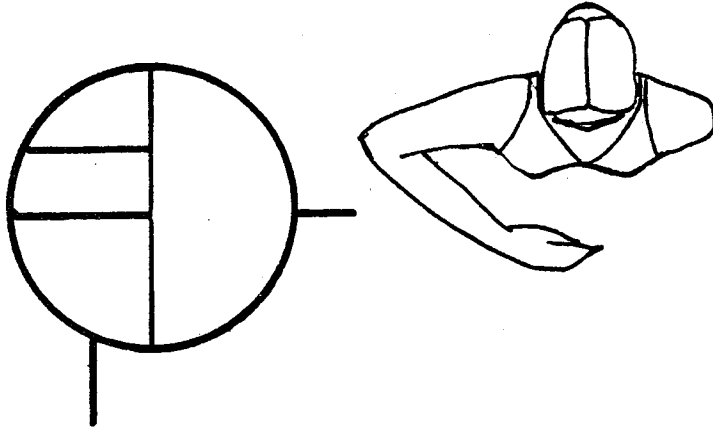

DEGREE TWO  
*One-Third Out, In Close Range*

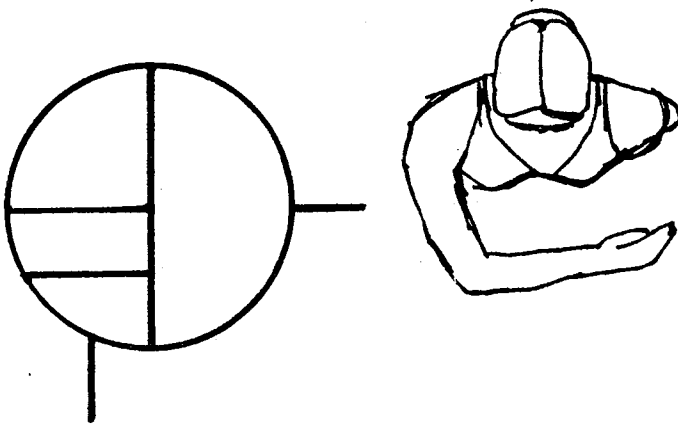

DEGREE THREE  
*Two-Thirds Out, In Close Range*

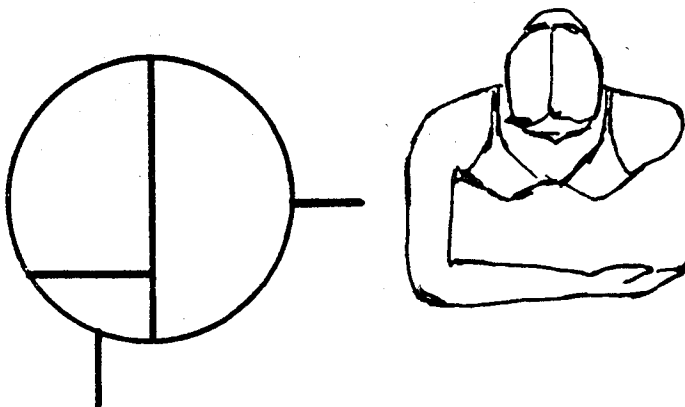

DEGREE FOUR  
*Farthest Out, In Close Range  
Hand In Line With Elbow*

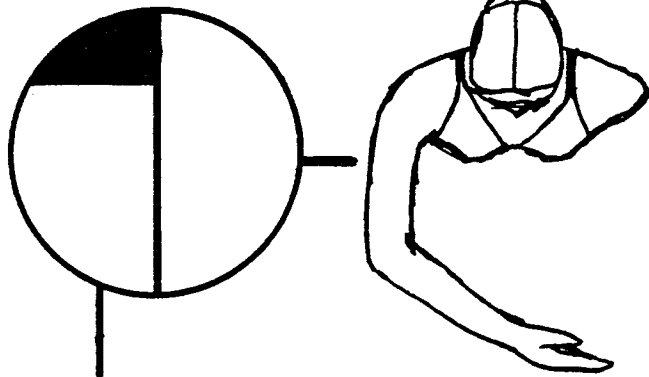

DEGREE FIVE

*Closest In, In Far Range  
Hand Slightly Outside of  
Elbow Range*

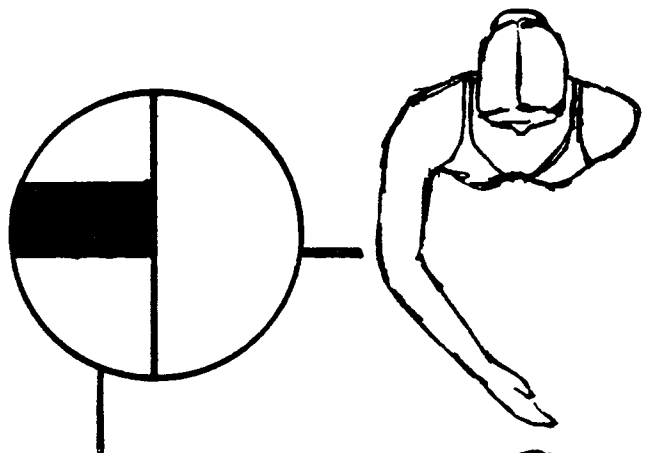

DEGREE SIX

*One-Third Out, In Far Range*

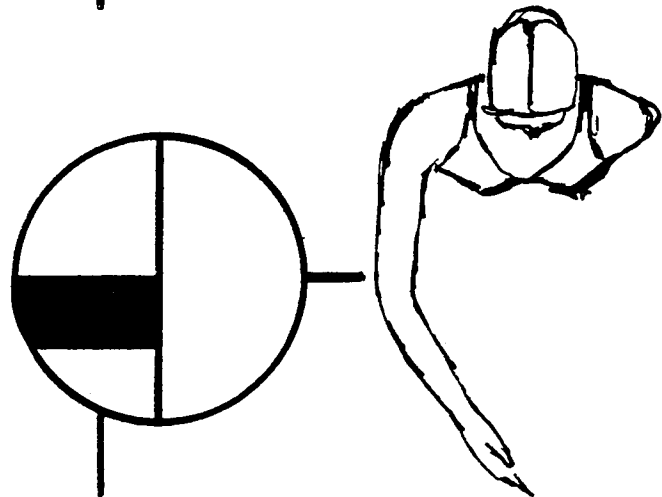

DEGREE SEVEN

*Two-Thirds Out, In Far Range*

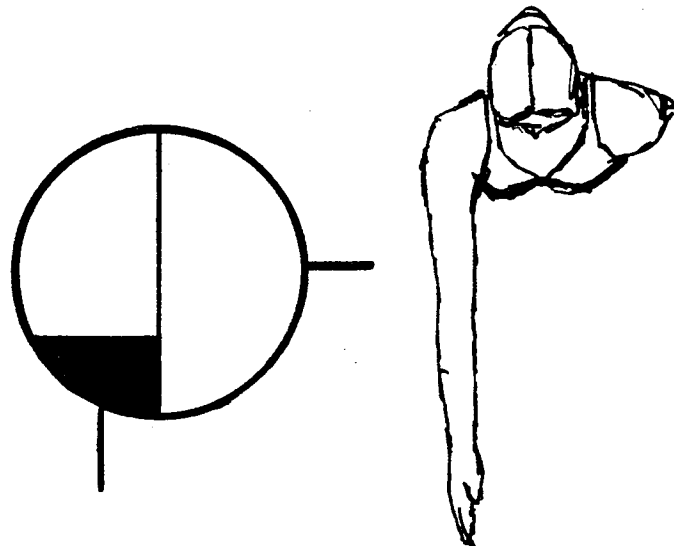

DEGREE EIGHT

*Farthest Out, In Far Range  
Arm Completely Stretched*

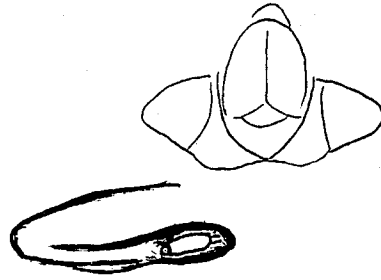
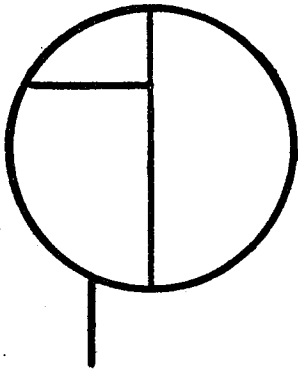

DEGREE ONE  
*Touching Standing Leg, Or Center Dot  
In Close Range*

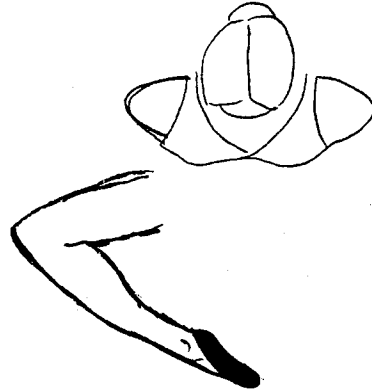
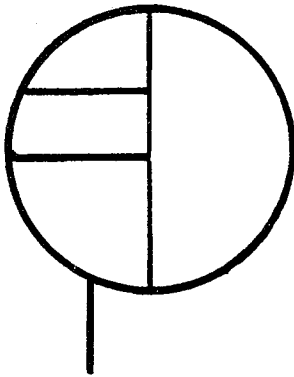

DEGREE TWO  
*One-Third Out, In Close Range*

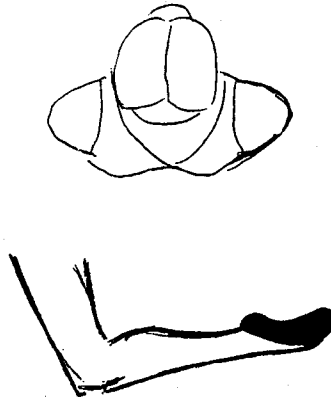
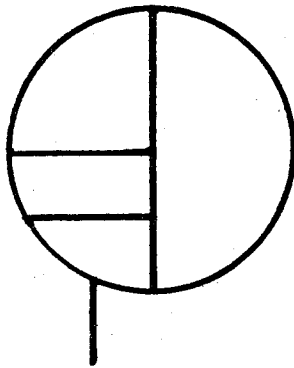

DEGREE THREE  
*Two-Thirds Out, In Close Range*

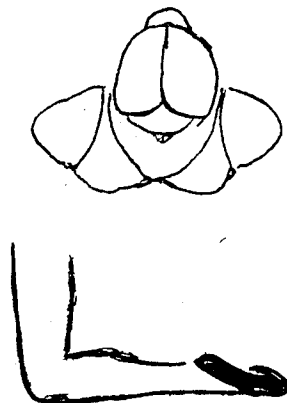
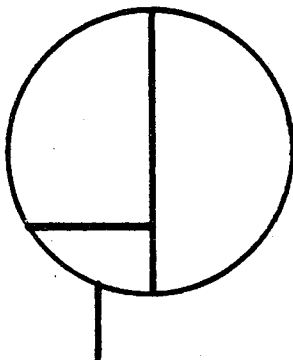

DEGREE FOUR  
*Farthest Out, In Close Range  
Foot In Line With Knee*

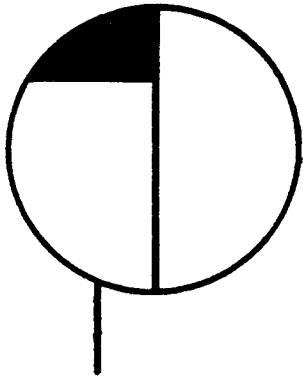

DEGREE FIVE

*Closest In, In Far Range  
Foot Slightly Outside of  
Knee Range*

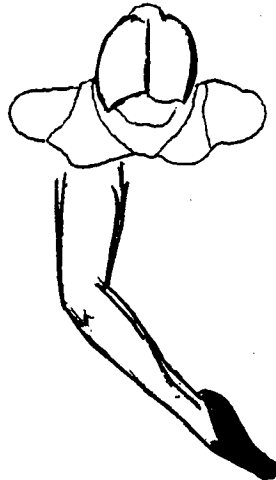
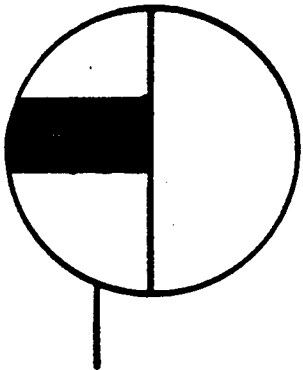

DEGREE SIX

*One-Third Out, In Far Range*

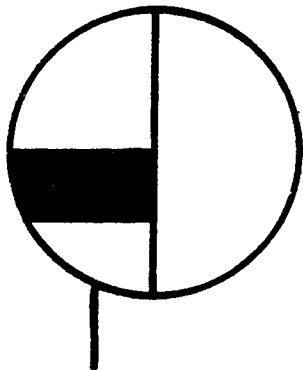

DEGREE SEVEN

*Two-Thirds Out, In Far Range*

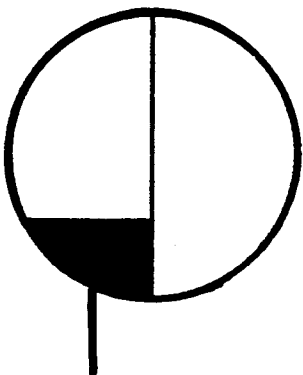

DEGREE EIGHT

*Farthest Out, In Far Range  
Leg Completely Stretched*

# THE SAGITTAL CENTER

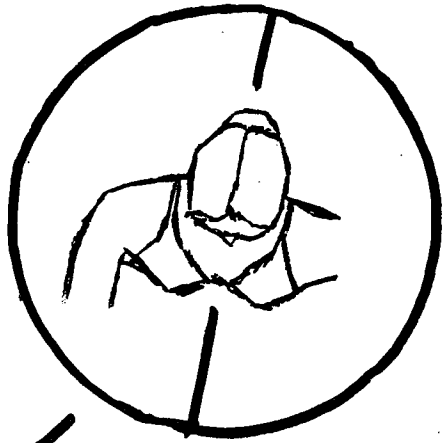

FACING  
BETWEEN  
FRONT WALL  
& FRONT CORNER

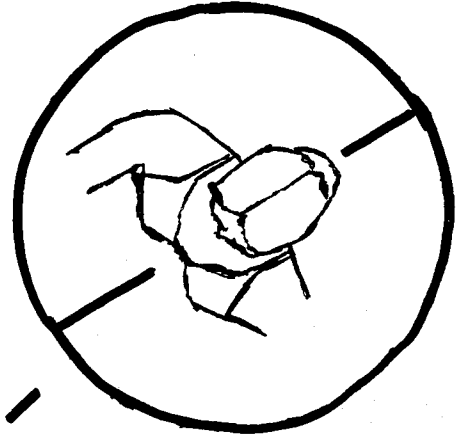

FACING  
BETWEEN  
FRONT CORNER  
AND SIDE WALL

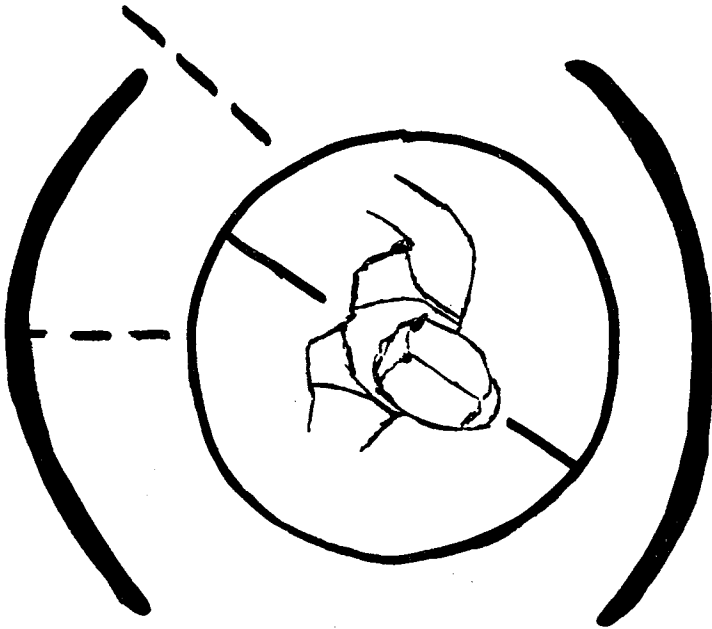

FACING  
BETWEEN  
SIDE WALL &  
BACK CORNER

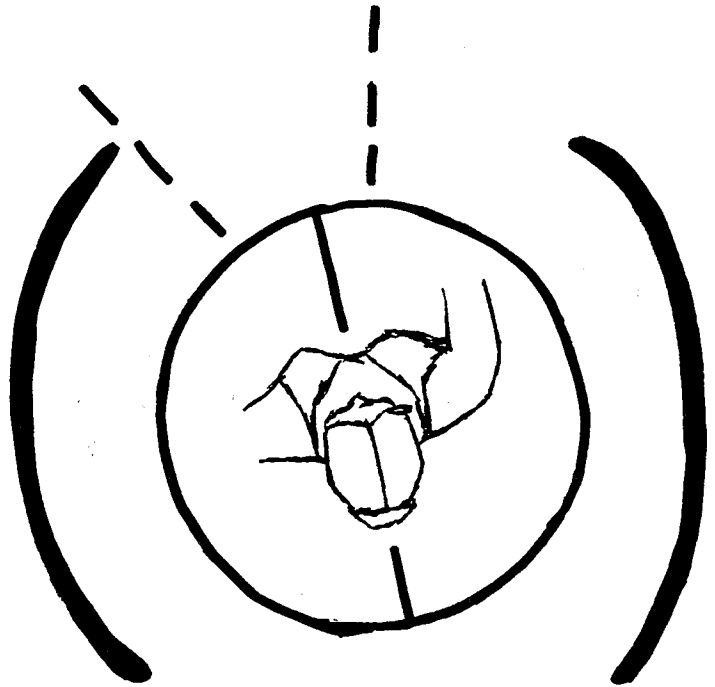

FACING  
BETWEEN  
BACK CORNER &  
BACK WALL

# IN-BETWEEN SPOKES

LIMBS BETWEEN FRONT WALL + CORNERS

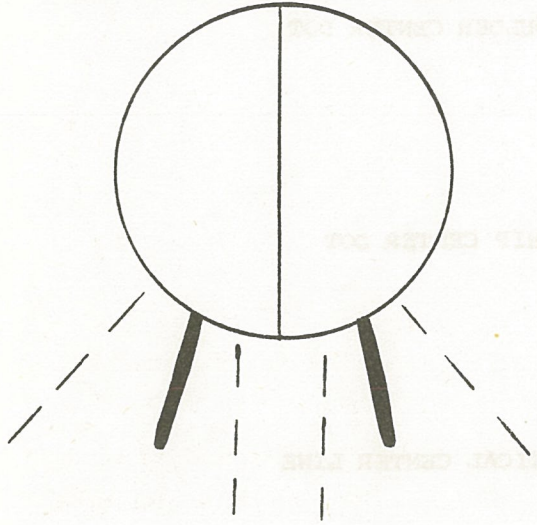

LIMBS BETWEEN FRONT CORNERS + SIDE WALLS

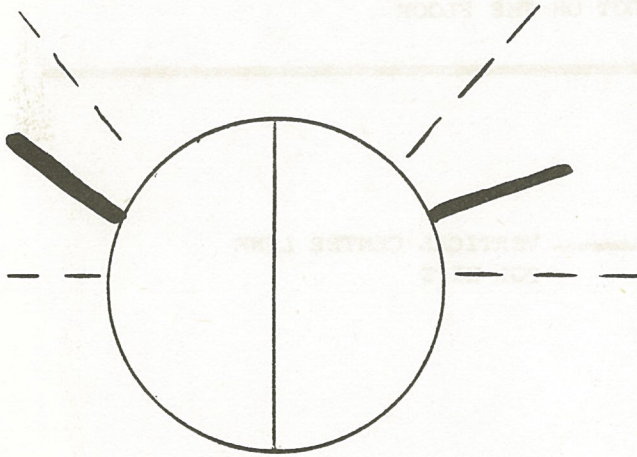
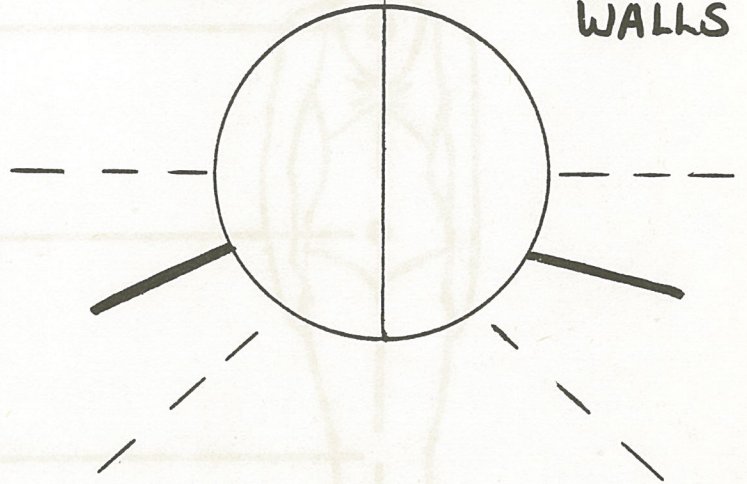

LIMBS BETWEEN SIDE WALLS AND BACK CORNERS

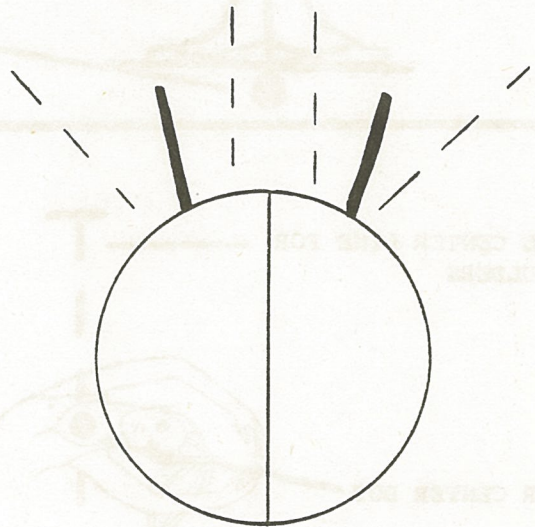

LIMBS BETWEEN BACK CORNERS AND BACK WALL

# SHOULDER CENTER / HIP CENTER

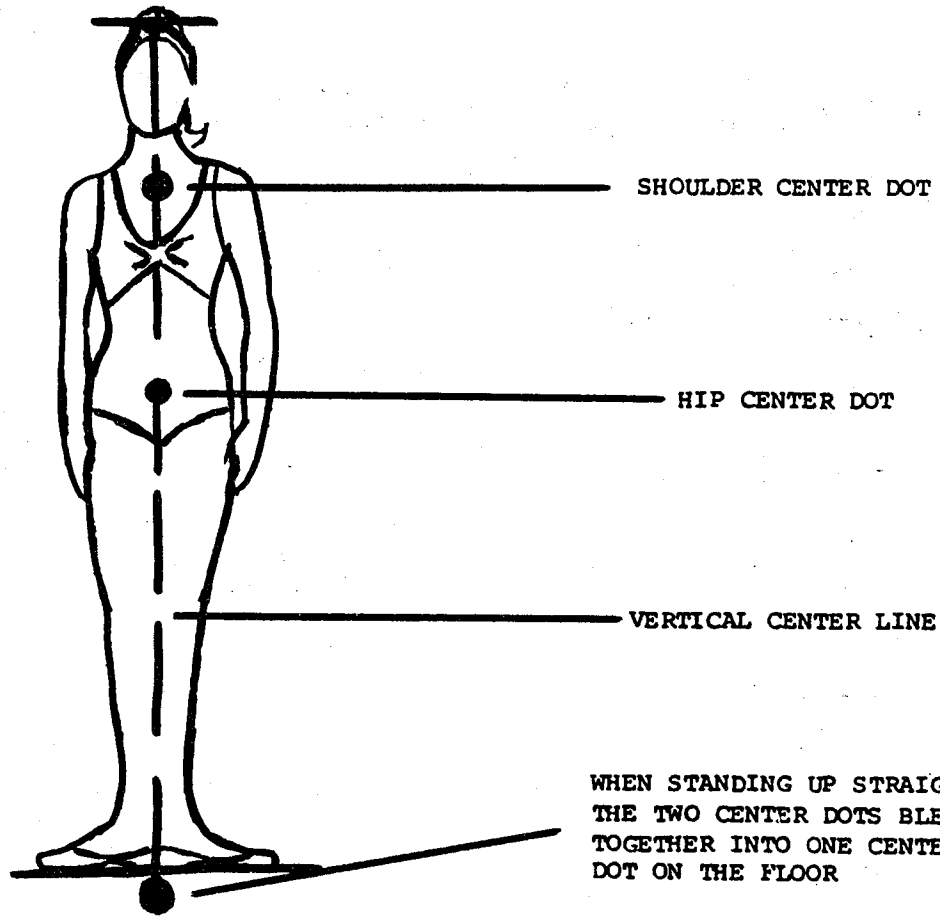

VERTICAL CENTER LINE FOR  
FOR SHOULDERS

SHOULDER CENTER DOT

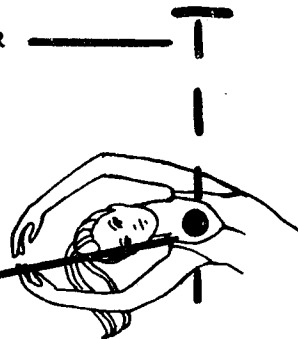

VERTICAL CENTER LINE  
FOR HIPS

HIP CENTER DOT

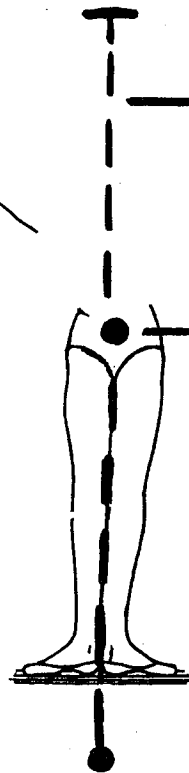

WHENEVER THE SHOULDERS  
ARE NOT DIRECTLY OVER  
THE HIPS, AS WHEN BENDING  
OR LYING ON THE GROUND,  
THERE ARE TWO CENTER DOTS,  
ONE FOR THE SHOULDERS AND  
ONE FOR THE HIPS. EACH  
CENTER HAS ITS OWN VERTICAL  
LINE AND DOT ON THE FLOOR.



# TWO CENTERS/TWO CYLINDERS

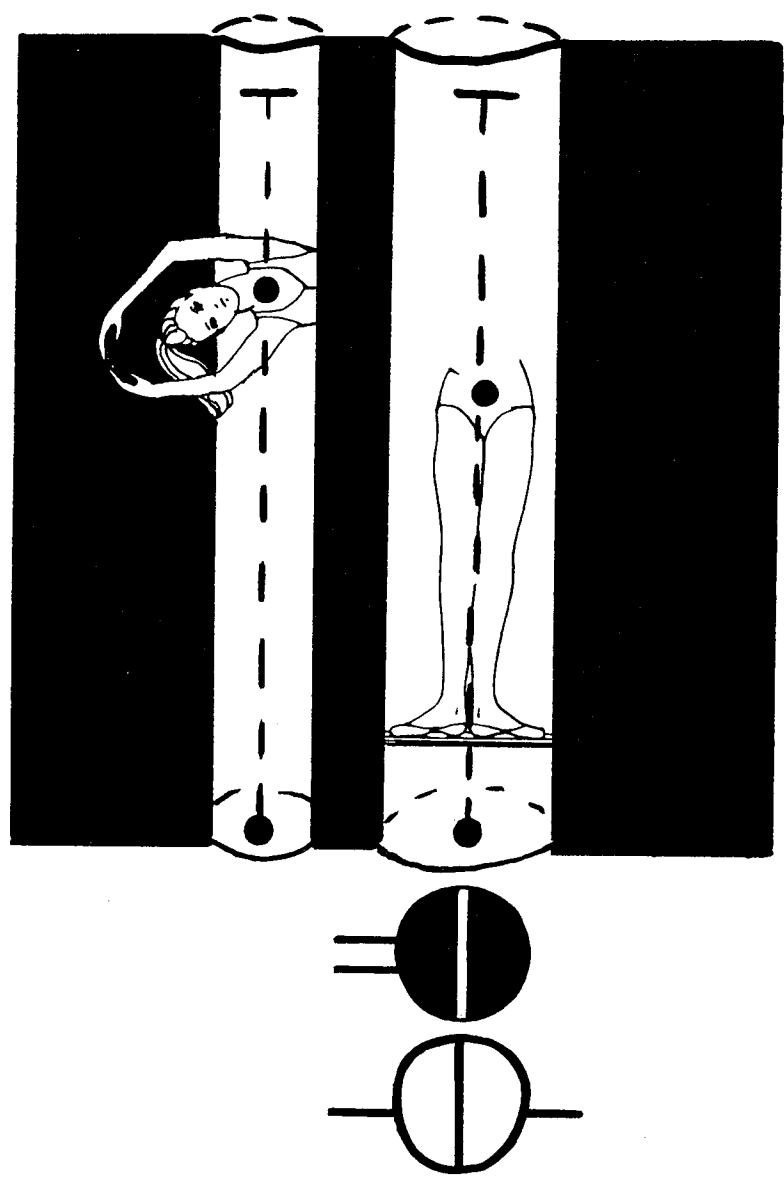

### THE IN-OUT POSITION SYMBOLS

1. Draw center dots through the hips and shoulders.
2. Draw imaginary vertical lines through the center dots.
3. Draw imaginary cylinders (always vertical) around the vertical lines.
4. The cylinder around the shoulders should be the length of the upper arm from center.
5. The cylinder around the hips should be the length of the upper leg from center.
6. Are the wrists to the front, side or diagonal of the center dot? Place the spokes on the symbol for the arms accordingly.
7. Are the wrists inside or outside the cylinder around the shoulders? Color the symbol accordingly.
8. Steps 6 and 7 above are also applied to the ankles and symbols for the legs.

# SHOULDER CENTER / HIP CENTER

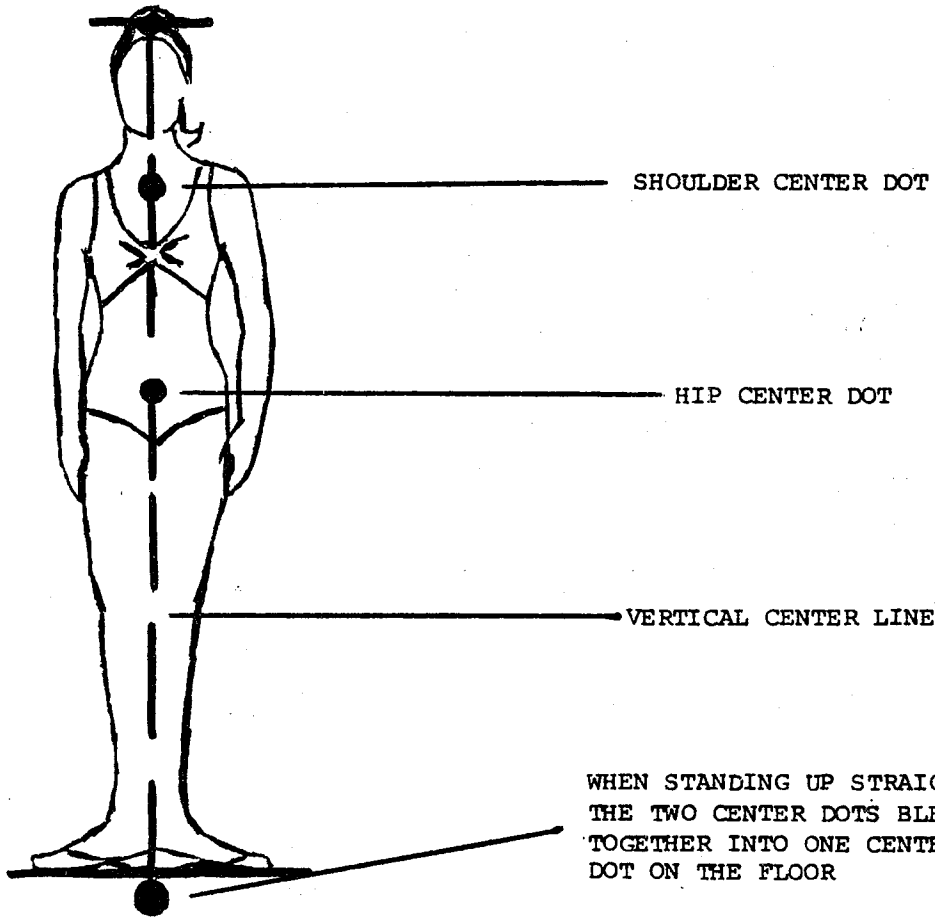

WHENEVER THE SHOULDERS ARE NOT DIRECTLY OVER THE HIPS, AS WHEN BENDING OR LYING ON THE GROUND, THERE ARE TWO CENTER DOTS, ONE FOR THE SHOULDERS AND ONE FOR THE HIPS. EACH CENTER HAS ITS OWN VERTICAL LINE AND DOT ON THE FLOOR.

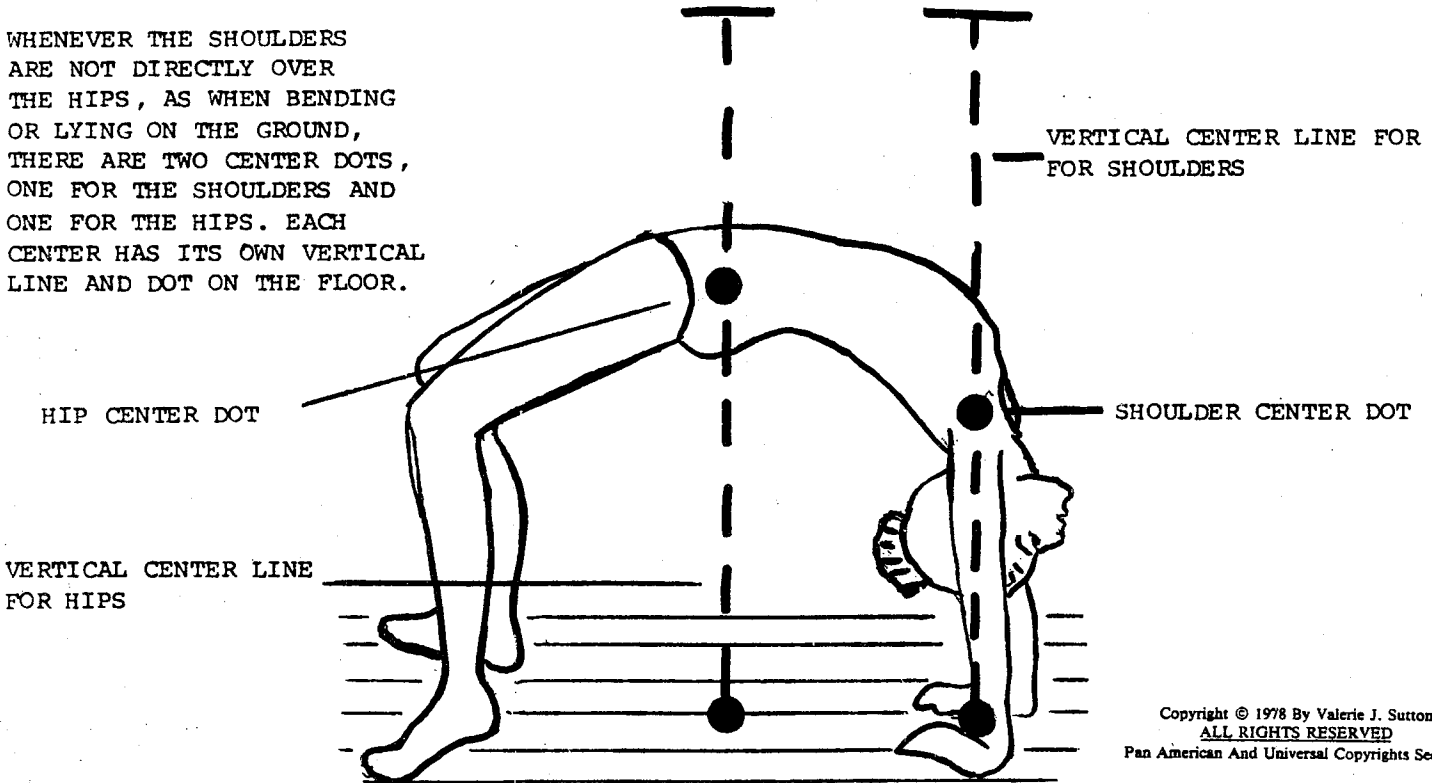

# TWO CENTERS/TWO CYLINDERS

## THE IN-OUT POSITION SYMBOLS

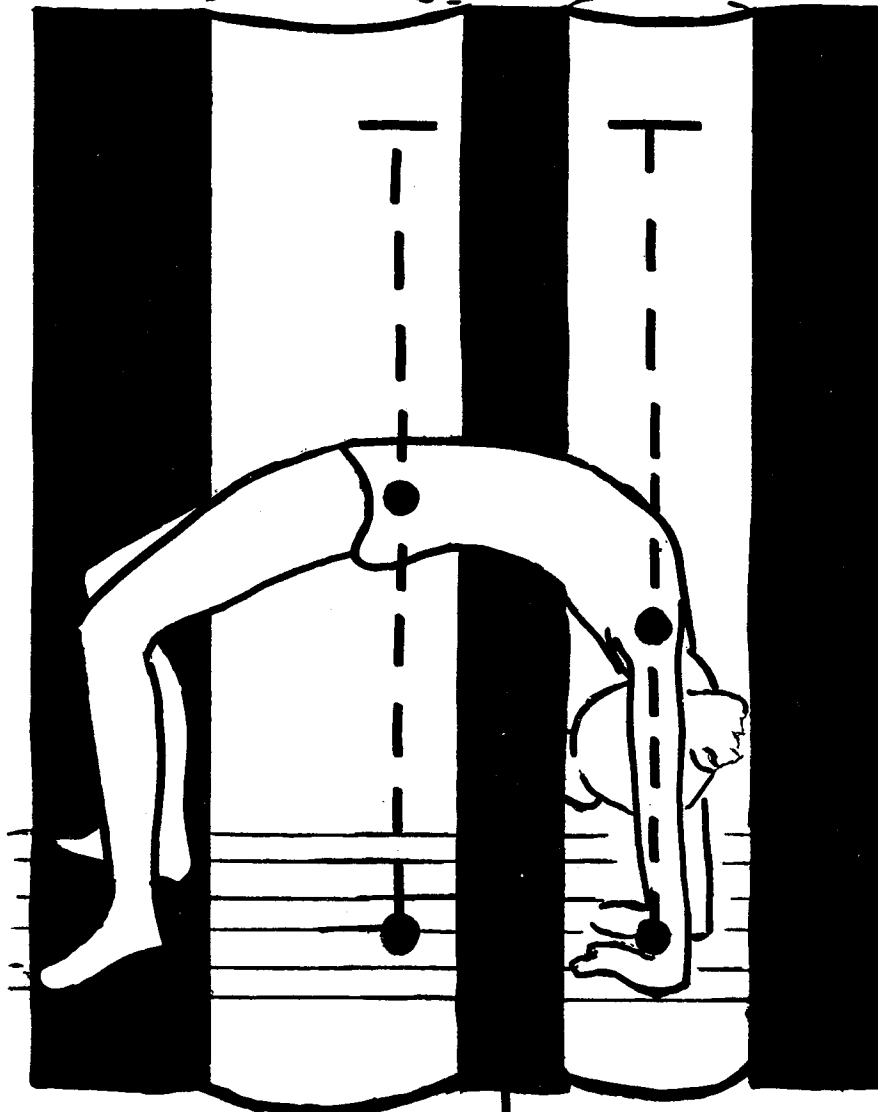

1. Draw Center Dots Through Hips & Shoulders.
2. Draw Imaginary Vertical Lines Through Center Dots.
3. Draw Imaginary Cylinders (Always Vertical) Around Vertical Lines.
4. The Cylinder Around The Shoulders Should Be The Length Of The Upper Arm From Center.
5. The Cylinder Around The Hips Should Be The Length Of The Upper Leg From Center.

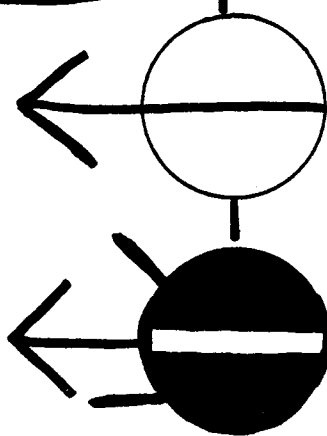

6. Are The Wrists To The Front, Side Or Diagonal Of The Center Dot? Place The Spokes On The Symbol For The Arms Accordingly.
7. Are The Wrists Inside Or Outside The Cylinder Around The Shoulders? Color The Symbol Accordingly.
8. Steps 6 and 7 above are also applied to the ankles and symbols for the legs.

# CIRCLE ALONG THE BODY'S FRONTAL PLANE

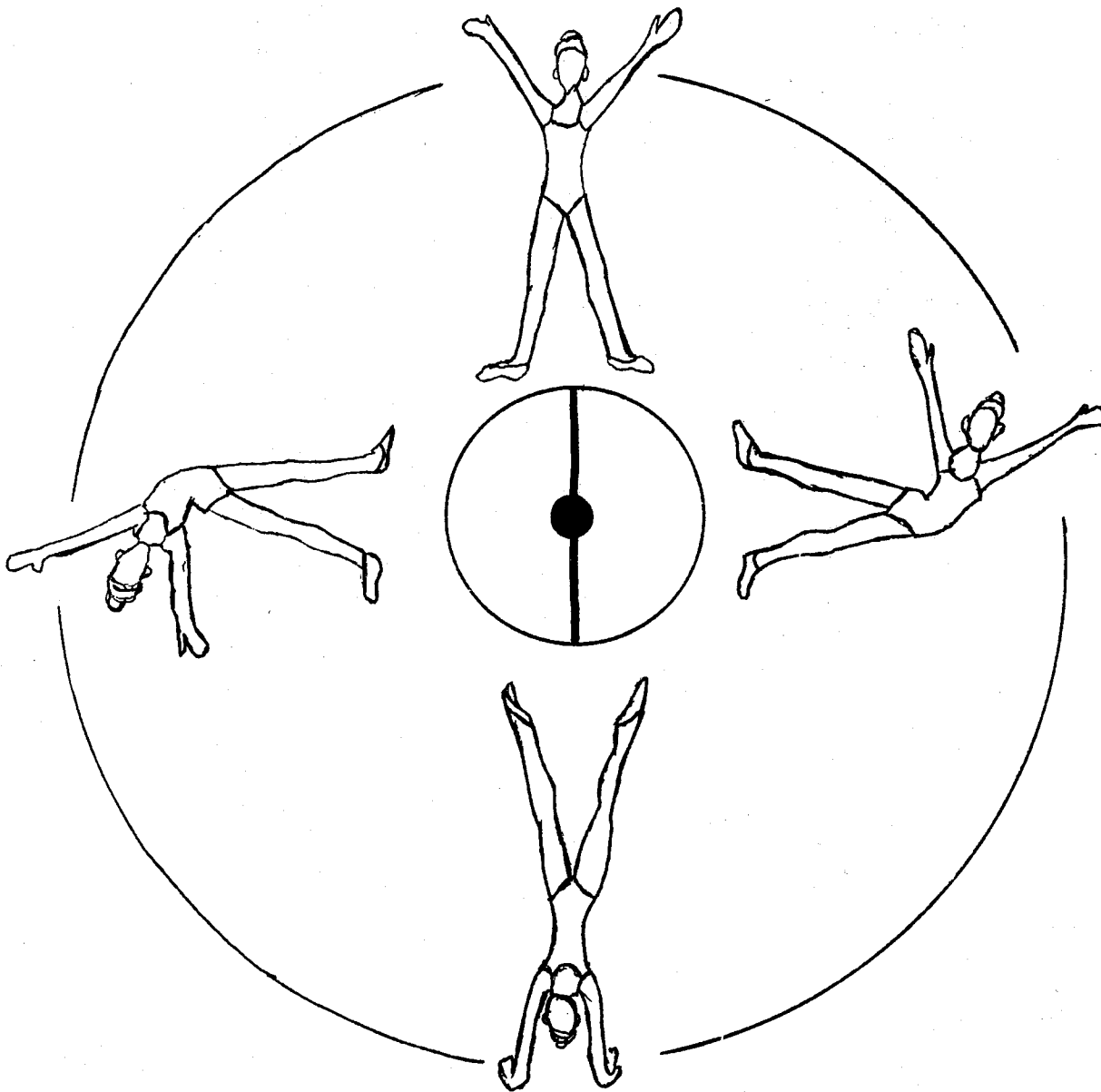

## CIRCLE WITH SAGITTAL CENTER

All figures bending to the side, doing a cartwheel, or lying on the ground on the side of the body are a part of a larger circle that is done along the Frontal Plane of the body. This circle has a Sagittal Center Line and Dot, and all figures in the circle will take the same Sagittal Center for their Position Symbols. All figures face the same direction in the circle, including the upside down figures.

# CIRCLE ALONG BODY'S FRONTAL PLANE

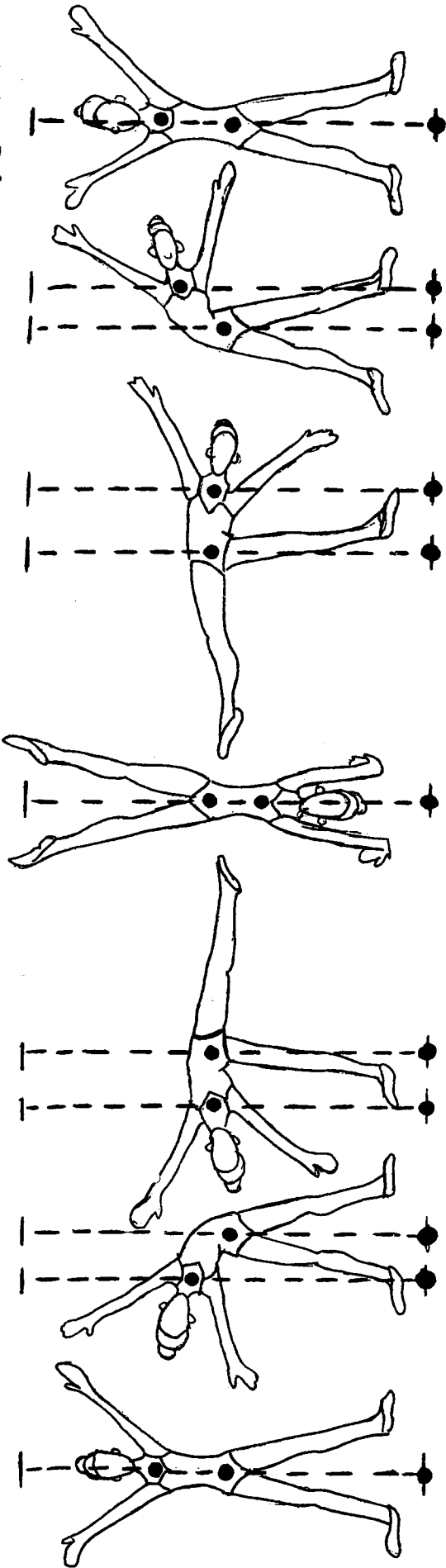

Copyright © 1978 By Valerie J. Sutton  
 ALL RIGHTS RESERVED  
 Pan American And Universal Copyrights Secured

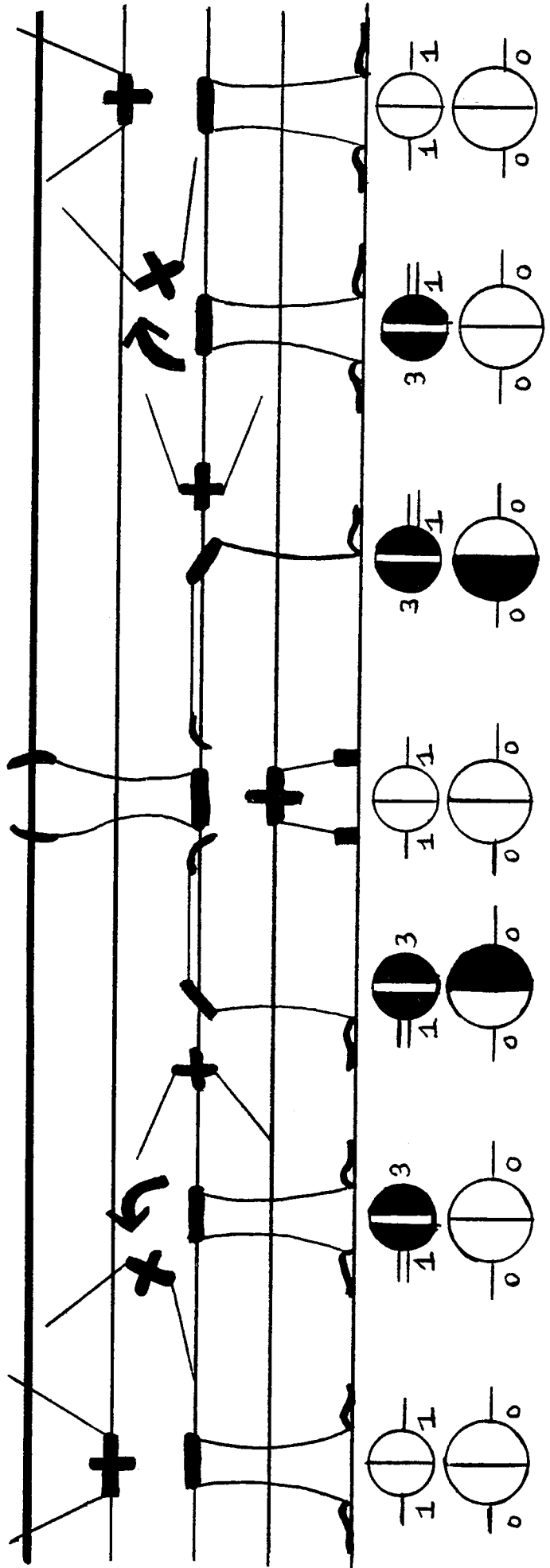

# CIRCLE ALONG THE BODY'S SAGITTAL PLANE

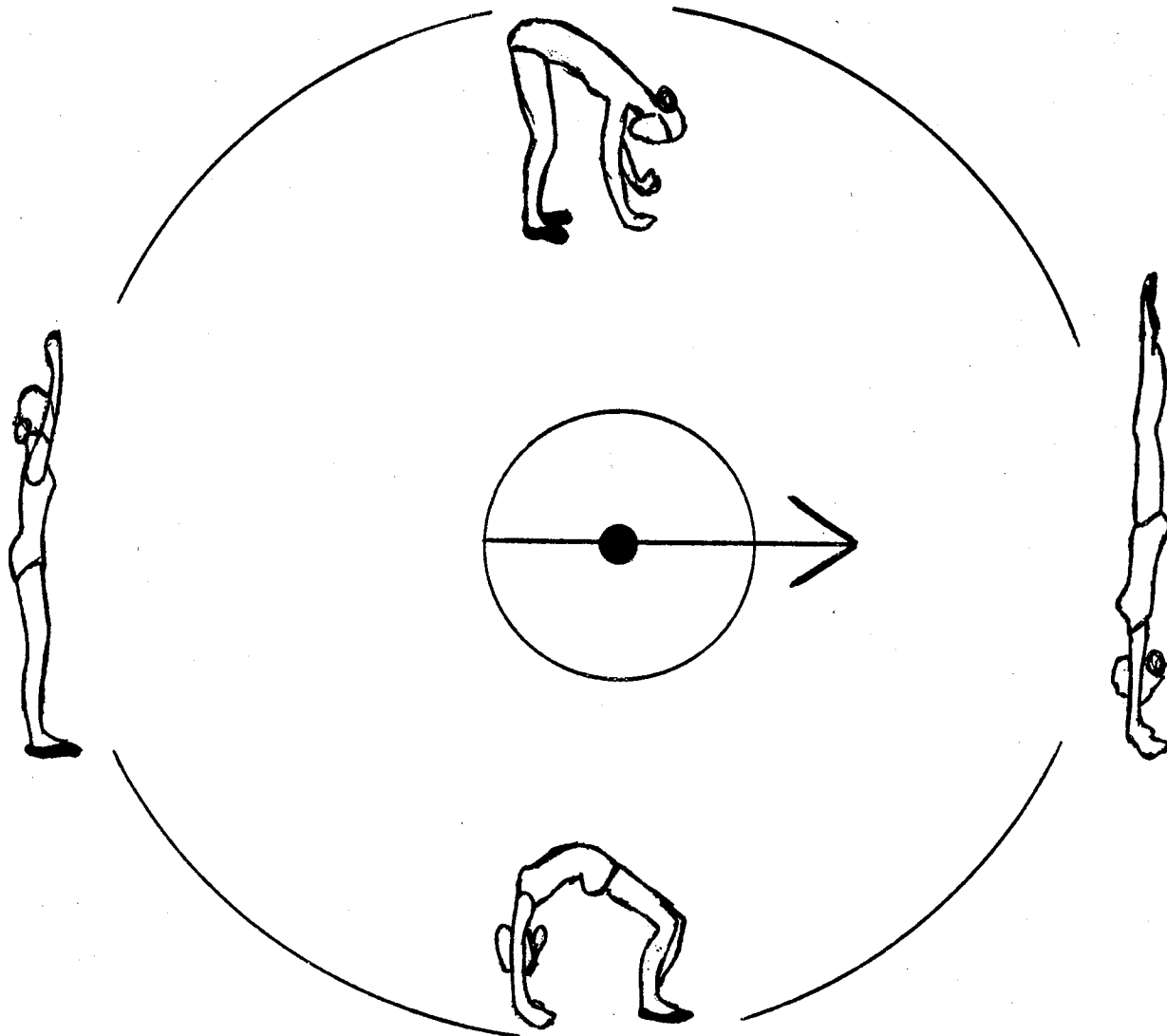

## CIRCLE WITH SAGITTAL CENTER

All figures bending forward or backward, doing a walkover, or lying on the ground on the stomach or back are a part of a larger circle that is done along the Sagittal Plane of the body. This circle has a Sagittal Center Line and Dot, and all figures in the circle will take the same Sagittal Center for their Position Symbols. All figures face the same direction in the circle, including the upside down figures.

# CIRCLE ALONG BODY'S SAGITTAL PLANE

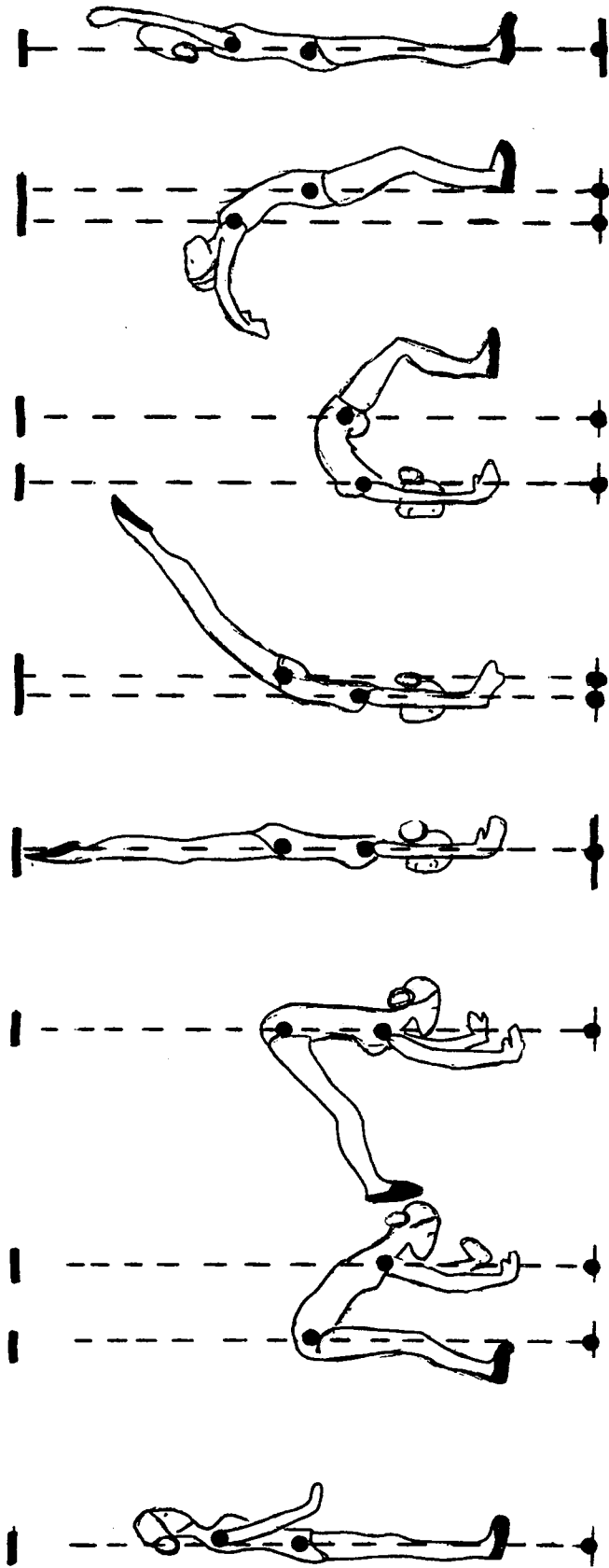

Copyright © 1978 By Valerie J. Sutton  
 ALL RIGHTS RESERVED  
 Pan American And Universal Copyrights Secured

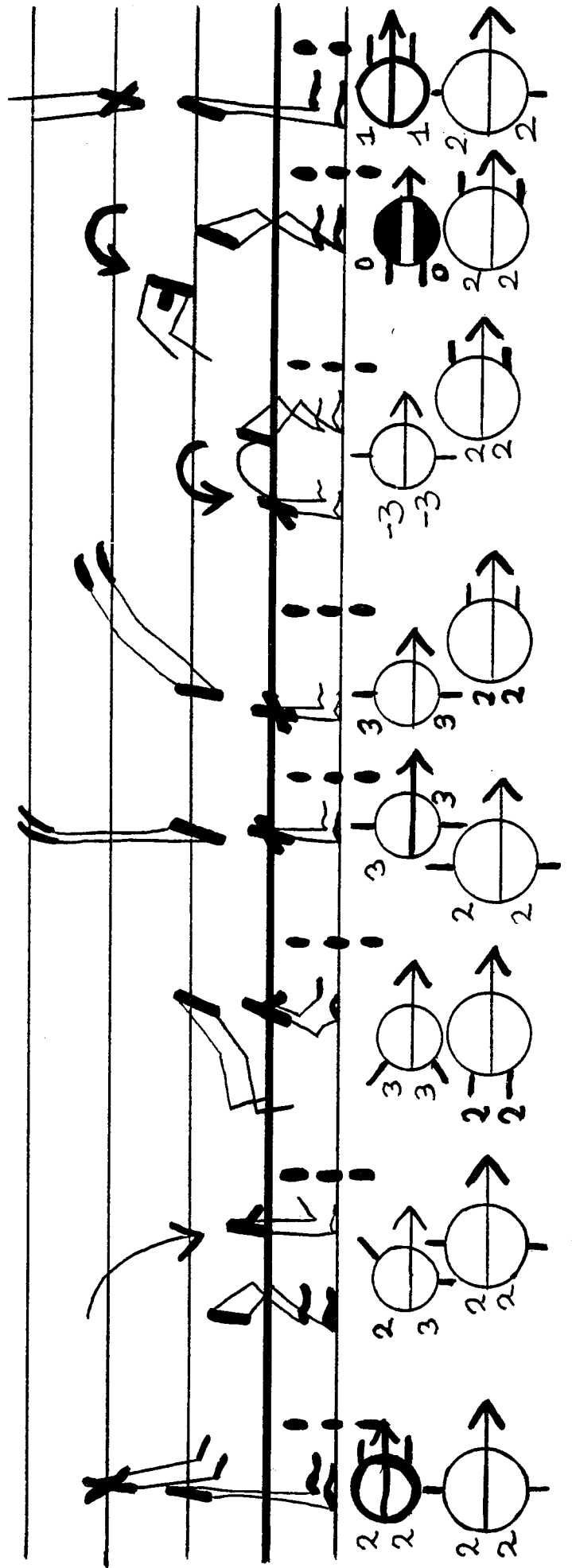



# ROTATED POSITION NUMBERS

0

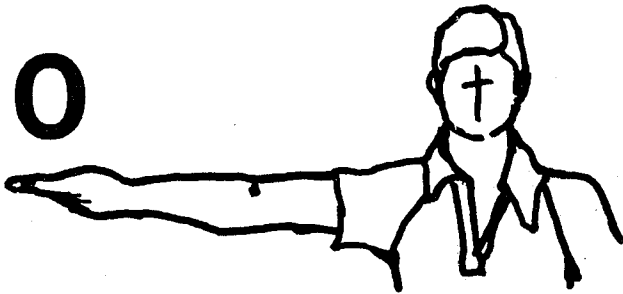

COMPLETE TURN-OUT

*Back Of Hand To Floor  
Arm At Shoulder Height*

*Back Of Hand To Torso  
When Arm Is Lowered*

1

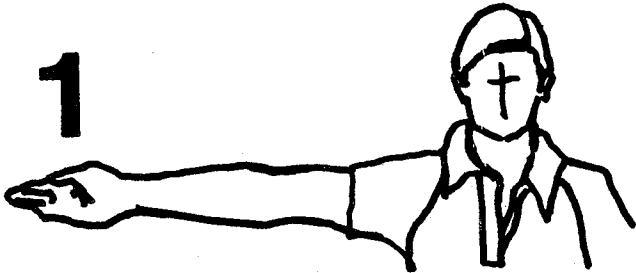

PARTIAL TURN-OUT

*Baby Finger To Floor  
Arm At Shoulder Height*

*Baby Finger To Torso  
When Arm Is Lowered*

2

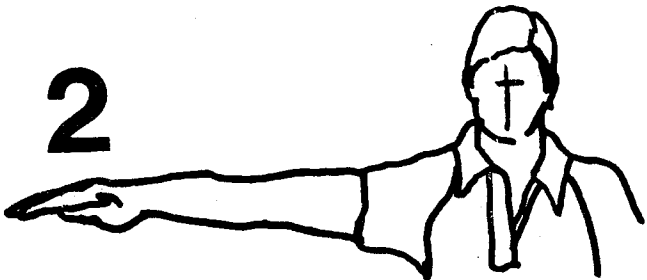

NATURAL

*Palm To Floor  
Arm At Shoulder Height*

*Palm To Torso  
When Arm Is Lowered*

3

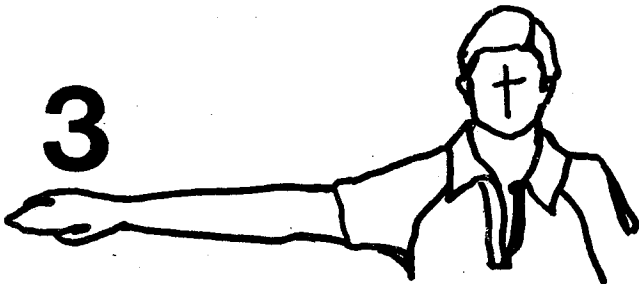

PARTIAL TURN-IN

*Thumb To Floor  
Arm At Shoulder Height*

*Thumb To Torso  
When Arm Is Lowered*

4

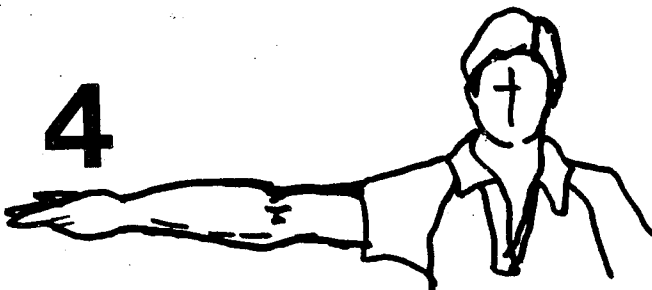

COMPLETE TURN-IN

*Back Of Hand To Floor  
Arm At Shoulder Height*

*Back Of Hand To Torso  
When Arm Is Lowered*

*(#4 Opposite To #0)*

# ROTATION ANALYSIS WHEEL: ARMS

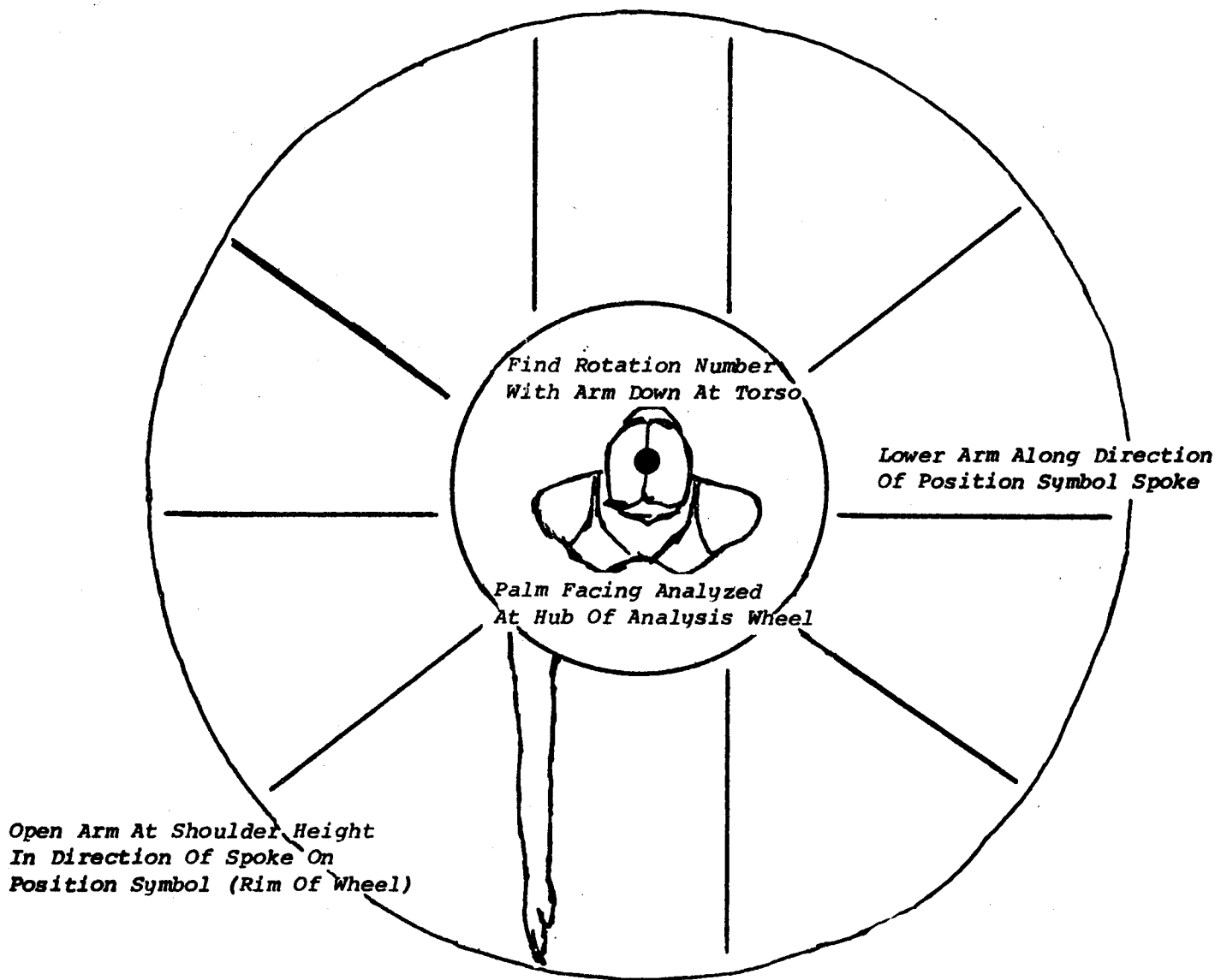

## FOR READING:

To Analyze Rotation Number of Arm: 1. Place arm straight down near torso. Place the arm to the front of the torso if the spoke on the Position Symbol is to the front, place the arm to the back of the torso if the spoke is to the back. The spoke on the Position Symbol states the side of the torso on which the arm is placed. 2. Place the arm in the Rotation Number stated in the notation. 3. Lift the arm along the direction of the spoke on the Position Symbol without changing rotation. 4. Bend the arm along the direction of the spoke on the Position Symbol without changing rotation.

## FOR WRITING:

To Analyze Rotation Number Of Arm: 1. Place your arm into the exact position you are trying to write. 2. Determine the plane of the body in which the arm is directed (spoke on Position Symbol, direction of arm). 3. Open the arm along this plane to the rim of the Analysis Wheel (shoulder height, straight arm). Be certain to open the arm without changing the rotation of the arm. 4. Lower the arm along the spoke on the Position Symbol to the torso to find the Rotation Number. Be certain to place the arm on the side of the torso that corresponds with the spoke on the Position Symbol.

# ROTATED POSITION NUMBERS

0

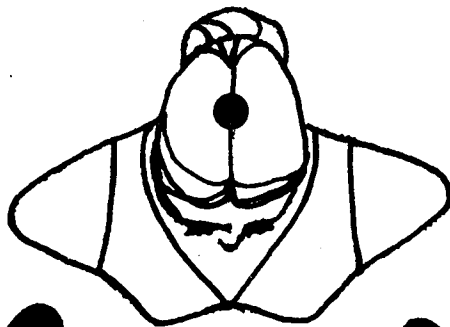

0

COMPLETE TURN-OUT  
Heels To The Center

COMPLETE TURN-OUT  
Heels To The Center

PARTIAL TURN-OUT  
Heel-Ankle To Center

1



1

PARTIAL TURN-OUT  
Heel-Ankle To Center

2

NATURAL, PARALLEL  
Ankles To The Center  
(Rotation Analyzed With Feet  
Directly Underneath Body)

4

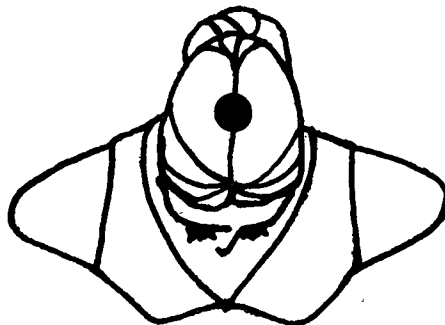

4

COMPLETE TURN-IN  
Toes To The Center

COMPLETE TURN-IN  
Toes To The Center

3



PARTIAL TURN-IN  
Toe-Ankle To Center

# ROTATION ANALYSIS WHEEL: LEGS

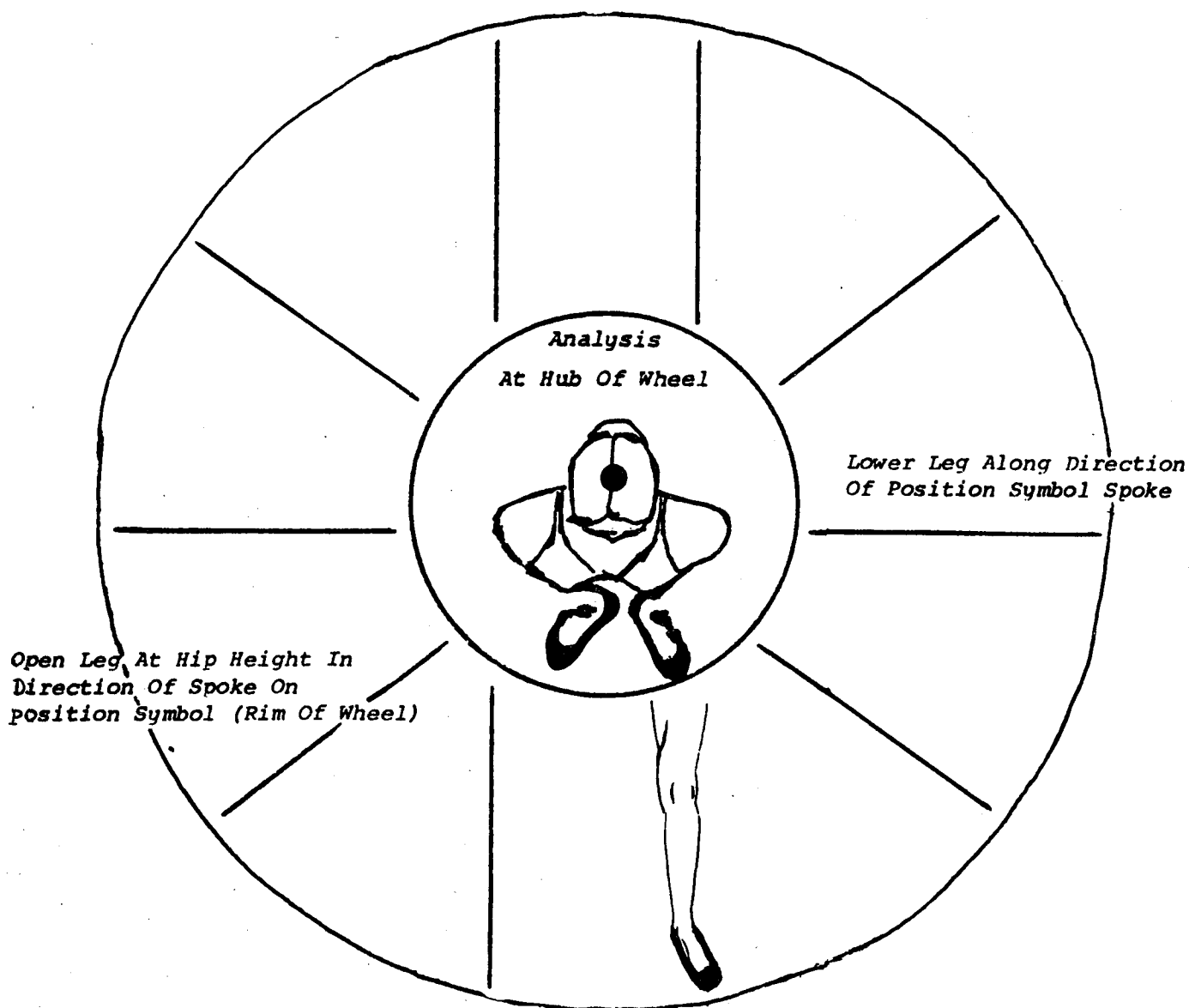

## FOR READING:

To Analyze Rotation Number Of Leg: 1. Stand squarely on the leg at the hub on the Analysis Wheel. The leg must be to the side of the center dot under the body, placed on the Frontal Plane of the body. 2. Place the leg in the Rotation Number stated in the notation. 3. Lift the leg along the direction of the spoke on the Position Symbol without changing the rotation. 4. Bend the leg along the direction of the spoke on the Position Symbol without changing rotation.

## FOR WRITING:

To Analyze Rotation Number of Leg: 1. Place your leg into the exact position you are trying to write. 2. Determine the plane of the body in which the leg is directed (spoke on Position Symbol, direction of leg). 3. Open the leg along this plane to the rim of the Analysis Wheel (hip height, straight leg). Be certain to open the leg without changing the rotation of the leg. 4. Lower the leg along the spoke on the Position Symbol to underneath the body, standing on the leg on the Frontal Plane of the body (to the side of the center dot). 5. Figure out the number of rotation by the facing of the ankles and heels to the center of the figure (vertical line).

## THE ROTATION NUMBERS

The numbers for rotation are placed below the stick figure, directly beside the Position Symbols underneath the staff. Numbers placed in the first row of Position Symbols represent the rotation of the arms. Numbers placed in the second row of Position Symbols represent the rotation of the legs.

There are four numbers for each figure at all times, one for each limb. Each number is placed to the side of the Position Symbol that corresponds to the limb the number describes. For example, the number for the right leg is written on the right leg's side of the Position Symbol.

The numbers for rotation are always analyzed in relationship to the imaginary vertical line running through the shoulders and hips of the figure. The numbers do not show a perfect anatomical description of rotation in the joints. Instead, the numbers show palm facing (or wrist facing) and ankle facing to the imaginary vertical line. How the hand or foot faces the vertical line determines the number.

When the figure stands straight, the center dot for the shoulders and the center dot for the hips are directly on top of each other. The vertical line running through the shoulders and the vertical line running through the hips blend together to make one vertical line. The palm facing numbers relate to this vertical line. The foot facing numbers also relate to this vertical line.

When the shoulders are not on top of the hips, as when bending or lying on the ground, there are two vertical lines, one running through the shoulder's center dot and one running through the hip's center dot. The palm facing numbers will always relate to the vertical line running through the shoulders. The foot facing numbers will always relate to the vertical line running through the hips.

### The Arms

When standing erect, the arms relate to the vertical line in a circle around the torso. With the arms hanging down along the torso of the body, the back of the hand to the body, as turned-out as possible, will be number 0. Back of Hand to the body will be number 0 whether it is to the front of the torso, side of the torso or back of the torso. Anywhere in the circle around the vertical line, if the back of the hand faces it with the arm turned-out, the number will be 0.

The other numbers are as follows:

Back Of Hand To Vertical Line, In Complete Turn-Out.....	Number 0
Baby Finger To Vertical Line In Partial Turn-Out.....	Number 1
Palm Of Hand To Vertical Line In Natural Position.....	Number 2
Thumb To Vertical Line In Partial Turn-In.....	Number 3
Back Of Hand To Vertical Line In Complete Turn-In.....	Number 4

When arms are raised away from the torso of the body, while standing, the arms are simply lowered to the torso to find the number. The arms, in other words, are lowered to the vertical line, to find the palm facing to the vertical line. The arms are always lowered along the spoke on the Position Symbol. They are lowered

along the direction in space in which the arm is projecting. If the spokes on the Position Symbols say the arms are to the side, on the Frontal Plane of the room, then the arms must be lowered, without changing any rotation in the joints, to the side of the torso to find the palm facing. If the arms are projecting to the front of the body, with the Position Symbol spokes to the front, then the arms are lowered to the front of the torso to find the palm facing. The spokes on the Position Symbol determine the side of the torso used to find the Rotation Number. They also determine the direction in space in which the limb is lowered.

If the arms are bent, then the arms are opened first to shoulder height in the direction of the spokes on the Position Symbol. They are then lowered as always along the spoke's direction and the number for the palm facing is analyzed at the torso. Again, the number is analyzed on the side of the torso that corresponds with the spoke on the Position Symbol.

When the body bends in any direction, the vertical line runs through the shoulders of the figure. The palm facing will continue to be analyzed in relationship to this vertical line. But now the vertical line does not necessarily run through the torso of the figure. The vertical line is vertical with the room, and the torso is going in another direction. The vertical line and the torso are no longer one and the same.

Think of the vertical line like an imaginary tube going from the ceiling to the floor. To analyze the Rotation Number, again, open the arms along the spokes of the Position Symbol, and always lower them to the vertical line (not to the torso). If the spokes on the Position Symbol state that both arms are to one side, for example, then both arms will be lowered to that one side to the vertical line. The palm facing is analyzed to that side of the vertical line. The spokes on the Position Symbol determine the side of the vertical line used to find the Rotation Number.

When the upper body lies on the ground (lying on the ground defined as "the shoulders touching the ground"), the vertical line still runs through the shoulders. Again, the palm facing is going to relate to the vertical line for the shoulders. To analyze the Rotation Numbers, the two arms must be lowered at all times. But how can the arms lower with the floor in the way? Do not stand the figure up. Instead, visualize a trap door through the floor and lower the arms along the spokes on the Position Symbol to the vertical line. The vertical line extends below the floor, through the trap door of the stage. Find the Rotation Number with the vertical line under the stage and place the number beside the Position Symbol for the upper body. Be certain to lower along the direction spokes.

Notice that 0 and 4 are complete opposites to each other. Both have the back of the hand touching the vertical line but 0 accomplishes this by turning the arm out and 4 accomplishes this by turning the arm in. The most accurate method of telling the difference between 0 and 4 is the elbow direction, while the back of the hand faces the vertical line. The number 0 always has the elbow bone pointing in the direction of the back of the hand. The number 4 always has the elbow bone pointing in the direction of the palm of the hand. This rule helps greatly when analyzing numbers while lying on the ground.

When the number 0 is used, the number 0 can be written beside the Position Symbol, or nothing can be written. When no number appears beside a Position Symbol the arm is considered to be in number 0.

If a Rotation Number is between one of the five numbers, then fractions can be used at will. For example, if the palm facing is between the baby finger facing the vertical line and the palm facing the vertical line, then the number would be 1 and 1/2, and so on.

### The Rare Minus Numbers

The arm can, at times, rotate beyond a full circle. In these rare cases, minus numbers occur. The full spectrum of numbers is as follows:

<u>TURN-OUT</u>	<ul style="list-style-type: none"> <li>-3.....Thumb To Vertical Line, Beyond Turn-Out, Beyond 0</li> <li>0.....Back Of Hand To Vertical Line, Complete Turn-Out</li> <li>1.....Baby Finger To Vertical Line, Partial Turn-Out</li> </ul>
<u>NEUTRAL</u>	<ul style="list-style-type: none"> <li>2.....Palm To Vertical Line, Natural</li> <li>3.....Thumb To Vertical Line, Partial Turn-In</li> <li>4.....Back Of Hand To Vertical Line, Complete Turn-In</li> </ul>
<u>TURN-IN</u>	<ul style="list-style-type: none"> <li>-1.....Baby Finger To Vertical Line, Beyond Turn-In, Beyond 4</li> <li>-2.....Palm To Vertical Line, Beyond Turn-In, Beyond -1</li> </ul>

Minus numbers are always beyond the normal rotation circle of five numbers (numbers 0-4). The thumb to the vertical line will always be a number three, with or without a minus before it. The number 1 is always baby finger to vertical line, with or without the minus before it. And the number 2 is always palm to vertical line, with or without the minus sign. The minus sign simply states that the palm facing has twisted or turned beyond the normal circle.

To determine the difference between a 1 and a -1, or a 2 and a -2, the following rule may be of help. All numbers describing turn-in (numbers 3, 4, -1 and -2 listed above) have the elbow bone of the arm projecting towards the palm of the hand. All numbers describing turn-out (numbers -3, 0, and 1 listed above), have the elbow bone of the arm projecting towards the back of the hand.

Number 2 is the neutral position. There are times when it's elbow will project to the back of the hand, like a turned-out arm, and times when it does not. But the number two never has its elbow projecting to the palm of the hand, like a turned-in arm. It is therefore closer to the turned-out numbers than the turned-in numbers.

If, at any time, it is hard to determine the number of the arm, rotate the arm to number 0 or number 4 and then rotate the arm around in the direction desired. Use number 0 and number 4 as a base to determine the other numbers. The elbows on number 0 and number 4 project very definitely to the back of the hand or the palm of the hand.

### When Standing On Hands

Rotation Numbers for standing hands are analyzed exactly the same as Rotation Numbers for standing feet. They are analyzed to the side of the vertical line running through the shoulders into the ground. (See explanation for Rotation Numbers For Legs). If the spokes on the Position Symbol for the upper body are already to the side of the body, then leave the hands where they are, unflex the wrists, and the side of the hand facing the vertical line will be the Rotation Number for that arm. If the spokes on the Position Symbol are in another direction other than side to the body, then the arm is opened on the spoke of the Position Symbol and brought down under the body so that the hands are to the side of the vertical line (just like standing feet), directly under the shoulders. Unflex the wrists, and the side of the hand facing the vertical line will be the Rotation Number for that arm.



### The Legs

When standing erect, the legs relate to the vertical line running through the center of the hips into the floor. Rotation Numbers for standing legs are always analyzed to the side of the vertical line, with the legs standing on the Frontal Plane of the body, the center dot between the two feet. Standing squarely on two feet, to the side of the center dot, the heels to the vertical line, as turned-out as possible, will be number 0. The rest of the numbers are as follows:

Heels To Vertical Line, In Complete Turn-Out.....	Number 0
Heel-Ankle To Vertical Line, Partial Turn-Out, Partial Heel And Partial Ankle.....	Number 1
Ankle To Vertical Line, Natural Position.....	Number 2
Toe-Ankle To Vertical Line, Partial Turn-In, Partial Ankle And Partial Toes.....	Number 3
Toes To Vertical Line, Complete Turn-In.....	Number 4

When the legs are raised away from the vertical line, while erect, the legs are simply lowered to the ground, placed on the Frontal Plane of the body, to the side of the vertical center line to find the number. How the foot faces the vertical center line determines the Rotation Number for the leg.

The legs are always lowered along the spoke on the Position Symbol. They are lowered along the direction in space in which the leg is projecting.

If the legs are bent, then open the legs to hip height in the direction of the spokes on the Position Symbol and lower the leg along that direction. Place the leg directly under the body, with feet on the Frontal Plane and analyze the Rotation number.

When the lower body begins to tilt, the vertical line runs through the hips of the figure. The foot facing will continue to be analyzed in relationship to this vertical line. But now the body is no longer in line with the vertical line, but is at an angle to it. To analyze the Rotation Numbers, the two legs must be lowered at all times so that the right foot is on the right side of the vertical line and the left foot is on the left side of the vertical line, both feet placed on the Frontal Plane of the body. To do this, do not stand the figure up. Instead, visualize a trap door through the floor and lower the legs to the vertical line, even though the feet may go through the floor. Find the Rotation Number, and place the number beside the Position Symbols for the lower body. Be certain to place the right foot to the figure's right side of the vertical line.

When the lower body lies on the ground (lying on the ground defined as "the hips touching the ground"), the vertical line still runs through the hips. Again, the foot facing is going to relate to the vertical line for the hips. Again, imagine a trap door through the floor. Do not stand the figure up. Instead, lower the legs along the spokes of the Position Symbol, through the floor, placing the right leg on the right side of the vertical line, and the left leg on the left side of the vertical line. Analyze the numbers in relation to the vertical line, and place the number beside the Position Symbol.

When the number 0 is used, the number 0 can be written beside the Position Symbol. Nothing can also be written. When no number appears beside a Position Symbol the leg is considered to be in number 0.

Again, as with the arms, if a Rotation Number is between one of the five numbers, then fractions can be used at will.

### The Rare Minus Numbers

The leg can, at times, rotate beyond a full circle. In these rare cases, minus numbers occur. The full spectrum of numbers is as follows:

#### TURN-OUT

- 2....Ankle To Vertical Line, Beyond Turn-Out, Beyond -1
- 1....Heel-Ankle To Vertical Line, Beyond Turn-Out, Beyond 0
- 0....Heel To Vertical Line, Complete Turn-Out
- 1....Heel-Ankle To Vertical Line, Partial Turn-Out

#### NEUTRAL

- 2....Ankle To Vertical Line, Natural, Parallel

#### TURN-IN

- 3....Toe-Ankle To Vertical Line, Partial Turn-In
- 4....Toes To Vertical Line, Complete Turn-In
- 3....Toe-Ankle To Vertical Line, Beyond Turn-In, Beyond 4

Minus numbers are always beyond the normal rotation circle of five numbers (numbers 0-4). The ankle to the vertical line will always be a number 2, with or without a minus before it. The number 1 is always Heel-Ankle to the vertical line, with or without the minus before it. And the number 3 is always Toe-Ankle to the vertical line, with or without the minus sign. The minus sign simply states that the foot facing has twisted or turned beyond the normal circle.

To determine the difference between a 1 and a -1, or a 2 and a -2, the following rule may be of help. All numbers without minus signs deal with the inside of the foot. Numbers without minus signs relate the heel, toes and insides of the feet to the vertical line. Numbers with minus signs are relating the outsides of the feet to the vertical line. -2, for example, is the outside ankle, where number 2 is the inside ankle.

If, at any time, it is hard to determine the number for the leg, rotate the leg to number 0 or number 4 and then rotate the leg around in the direction desired.

### When Upside-Down

An upside-down position is defined as the following: When the hips are placed directly over the shoulders, so that the hip's center dot and the shoulder's center dot are in line with each other. As soon as the figure has the same vertical line running through the hips and shoulders it is considered to be an upside-down figure.

The arms are always lowered to the vertical line, and in upside-down positions they are either lowered or treated as standing on the hands (see previous explanation). The legs, however, are in this case the exception to the rule. The legs will not be lowered to the vertical line when upside-down, but will be raised to the vertical line. If the legs are already raised and on the Frontal Plane of the body, then keep the legs where they are and analyze the number in relation to the vertical line. If the legs are not already raised, then simply raise them along the Position Symbol spokes to the vertical line to analyze the number. In all other cases, the legs are lowered to the vertical line.

# ALWAYS LOWER TO CENTER

BOTH ARMS LOWER TO  
VERTICAL CENTER LINE

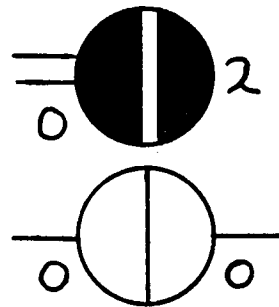
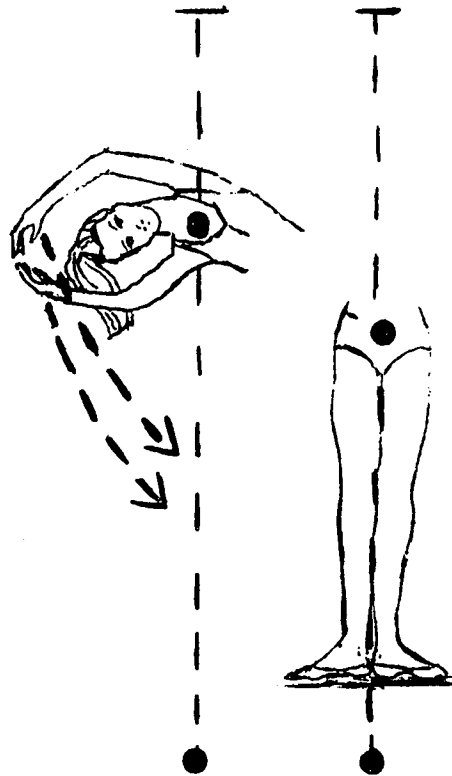

## ANALYZING ROTATION NUMBERS

1. Always lower the limb, along the spokes on the Position Symbol, to the Vertical Center Line.
2. When both arms are to one side of the center line, then both spokes on the Position Symbol are to one side. Both limbs will be lowered to that side, to the Vertical Center Line.
3. Be certain, when lowering the arm, to place the arm to the correct side of the Vertical Center Line. The arms will always be lowered to the side of the Vertical Line that corresponds with the spokes on the Position Symbol. When both arms are to one side, then both arms will be lowered to that one side of the Vertical Center Line.
4. Find the palm facing with the Vertical Center Line, and write the number below the staff beside the Position Symbol.

# ROTATION NUMBERS FOR ARMS WHILE LYING ON THE GROUND

Do not stand the person up to find the Rotation Number. Instead keep the figure lying on the ground. Pretend there is an Imaginary Trap Door under the limb.

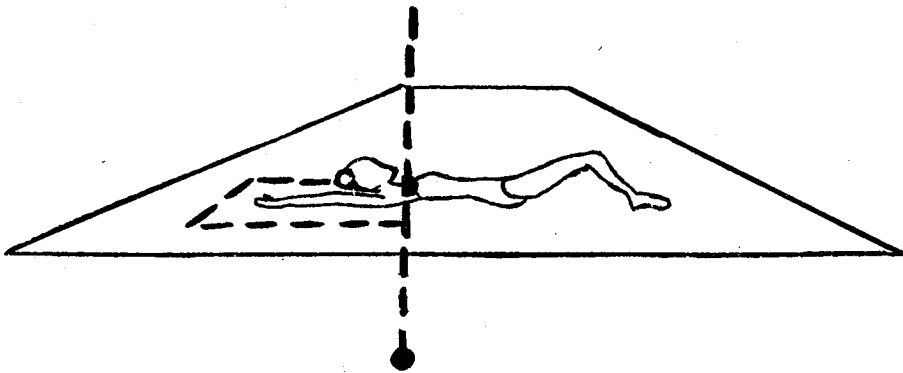

Lower the arm through the Imaginary Trap Door. As you lower the arm, be certain to keep the arm to the proper side of the Center Line. The proper side of the Center Line is stated on the Position Symbol for the figure. If the spoke on the Position Symbol states the arm is front, then the arm is lowered to the front of the Center Line. If the spoke on the Position Symbol states the arm is side, then the arm is lowered to the side of the Center Line, and so on. Once the arm is lowered, what part of the hand faces the Center Line? In this diagram, it is the back of the hand, which is number 0.

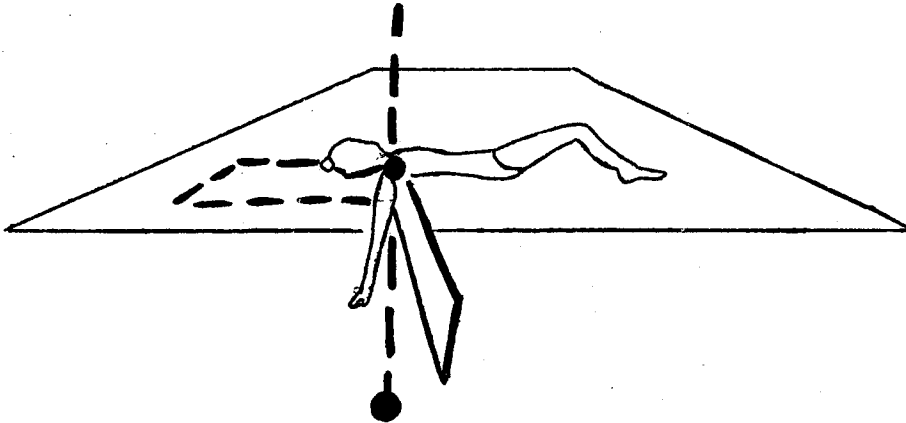

# ROTATION NUMBERS FOR LEGS WHILE LYING ON THE GROUND

Do not stand the person up to find the Rotation Number. Instead keep the figure lying on the ground. Pretend there is an Imaginary Trap Door under the limb.

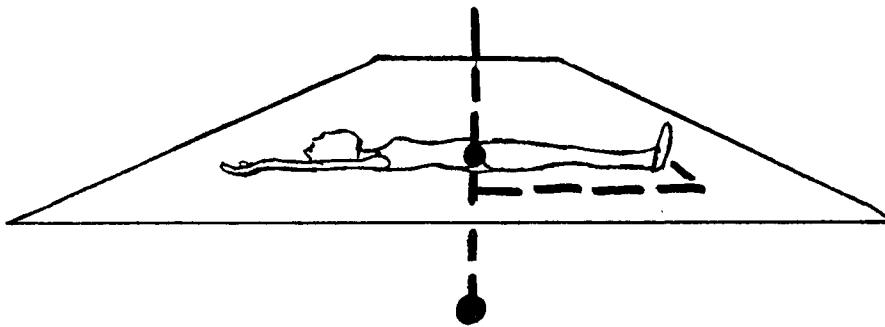

Lower the leg through the Imaginary Trap Door. Remember that legs are different than arms. The leg is lowered to the side of the Vertical Center Line at all times. What part of the foot faces the Center Line? In this diagram it is the ankle of the foot, which is number 2.

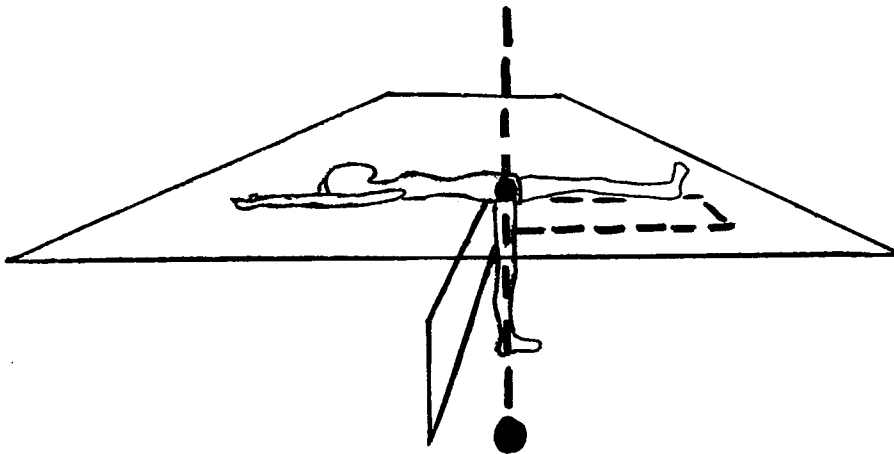

# LYING ON THE GROUND

← FURSE

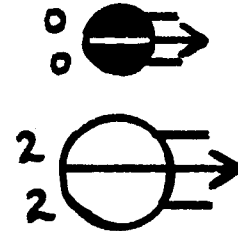
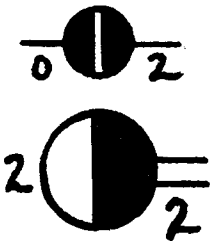
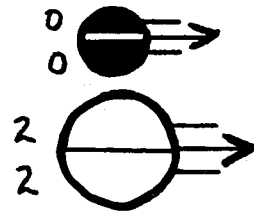
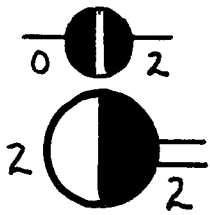

# LYING ON THE GROUND

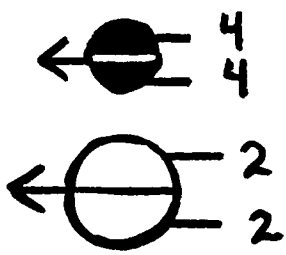
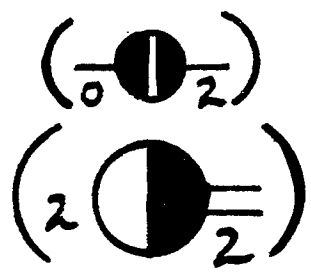
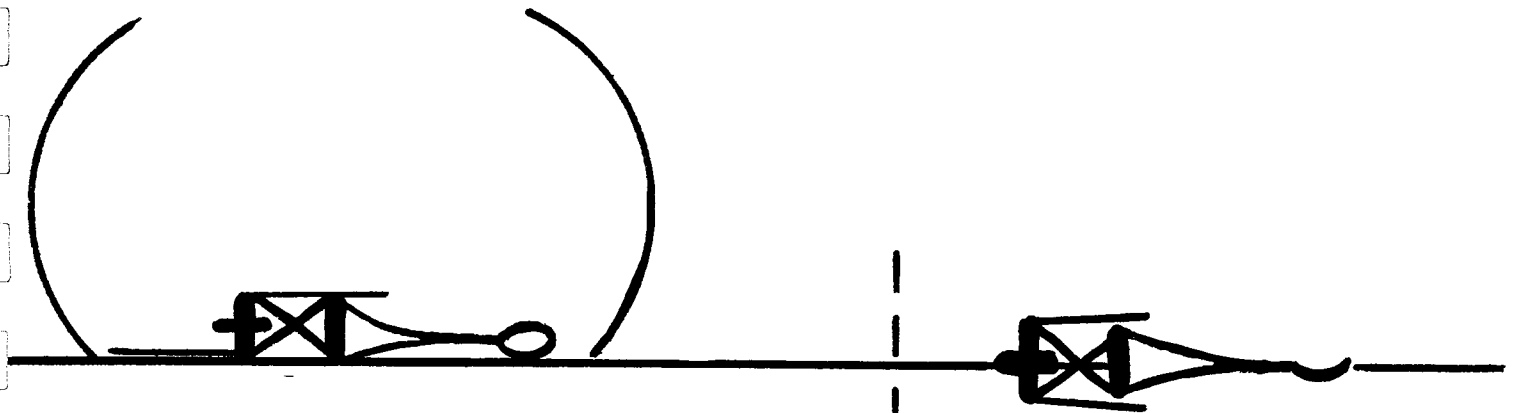
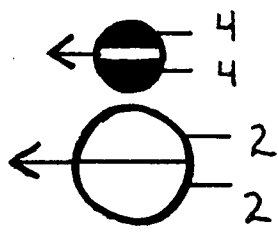
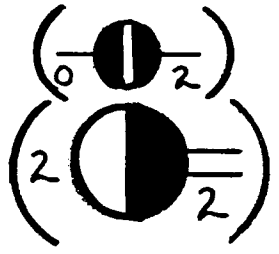
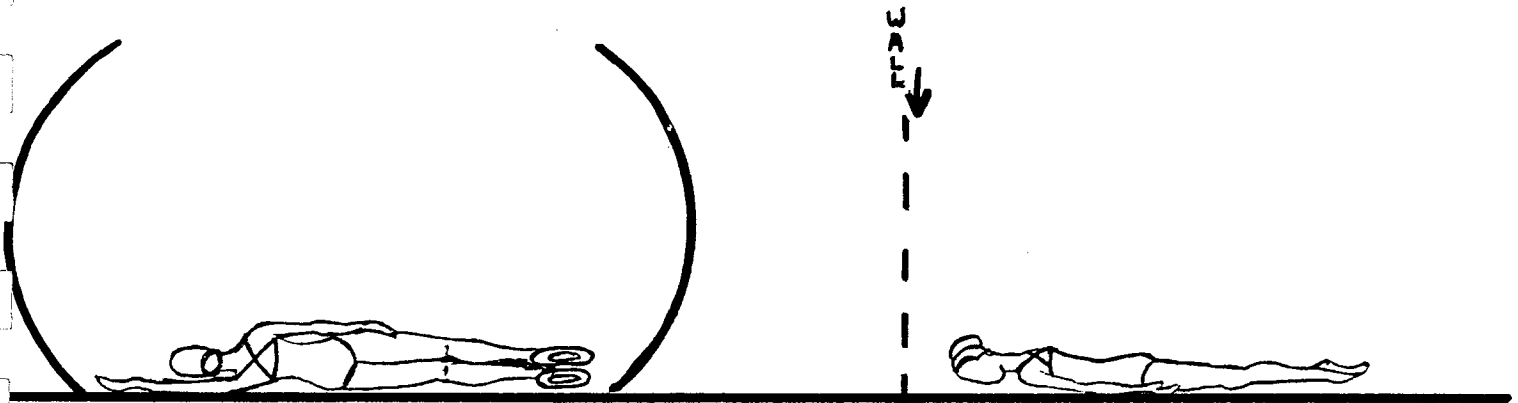

# LYING ON THE GROUND

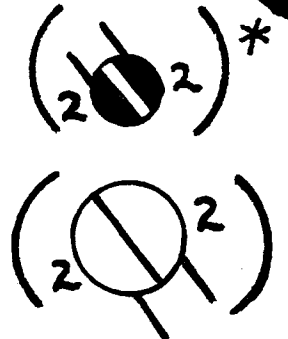
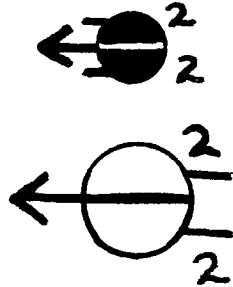
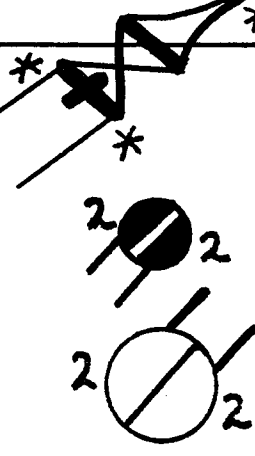
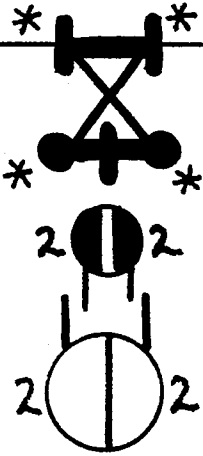
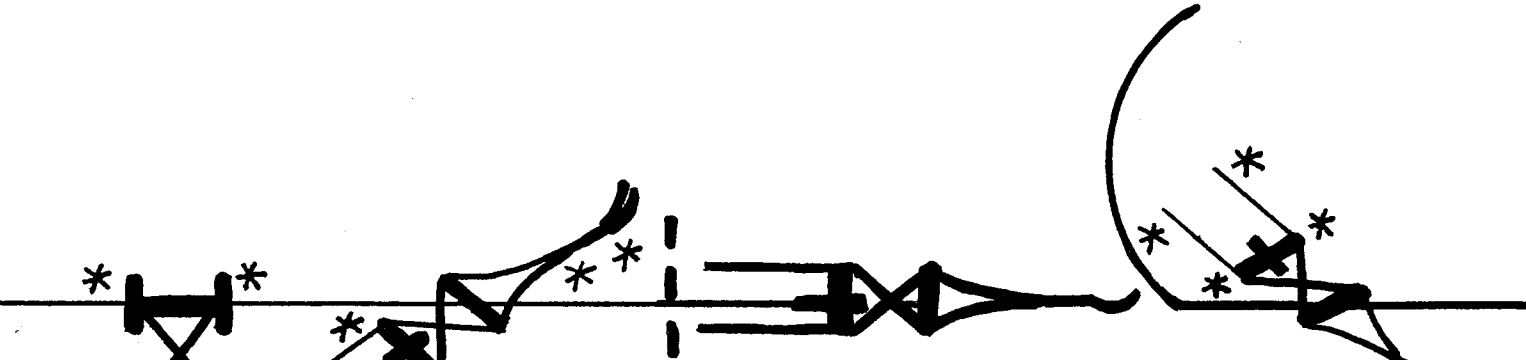
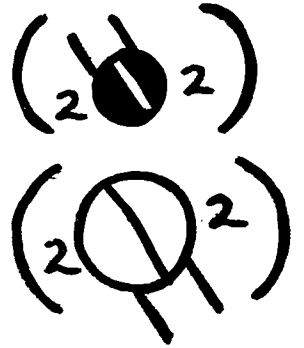
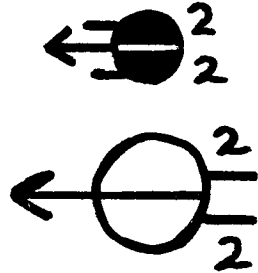
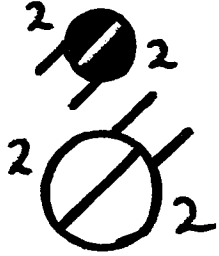
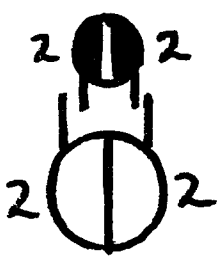
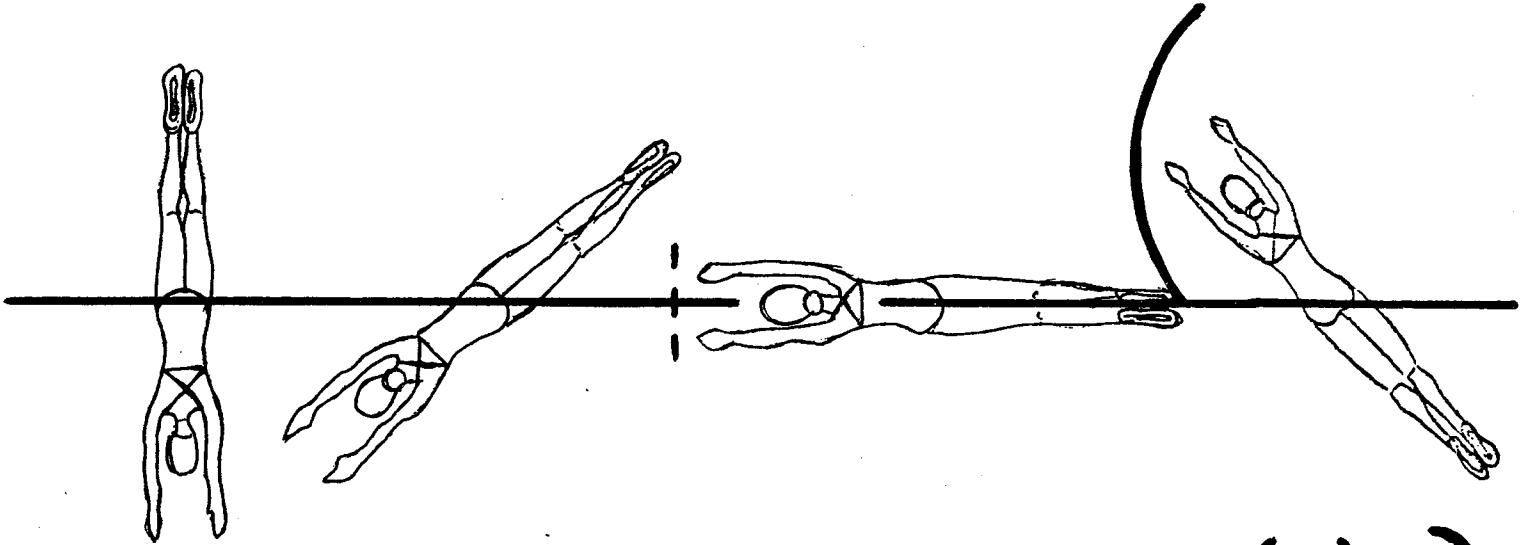



# LYING ON THE GROUND

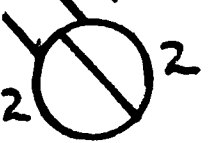
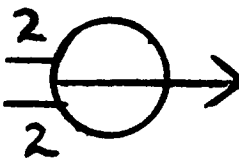
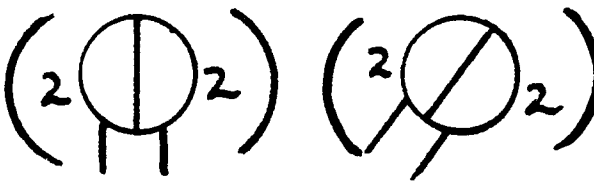
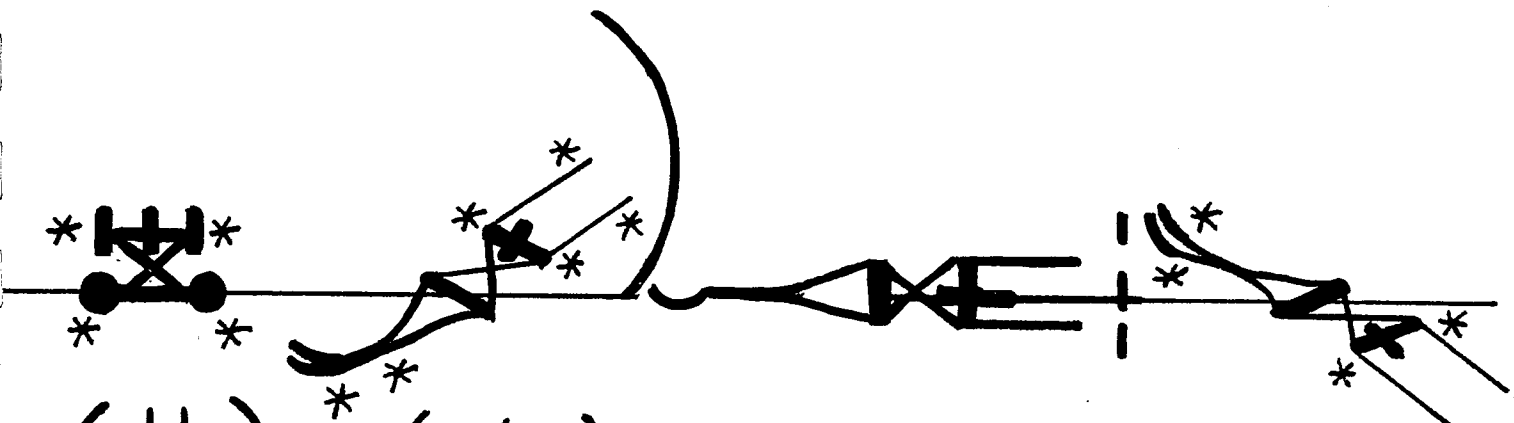
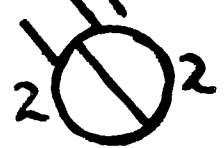
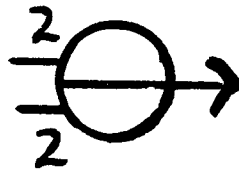
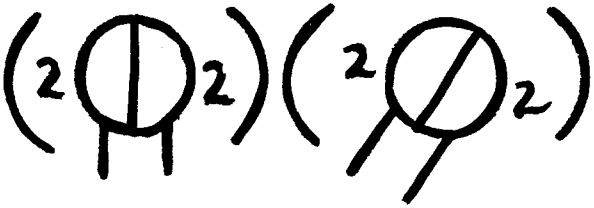
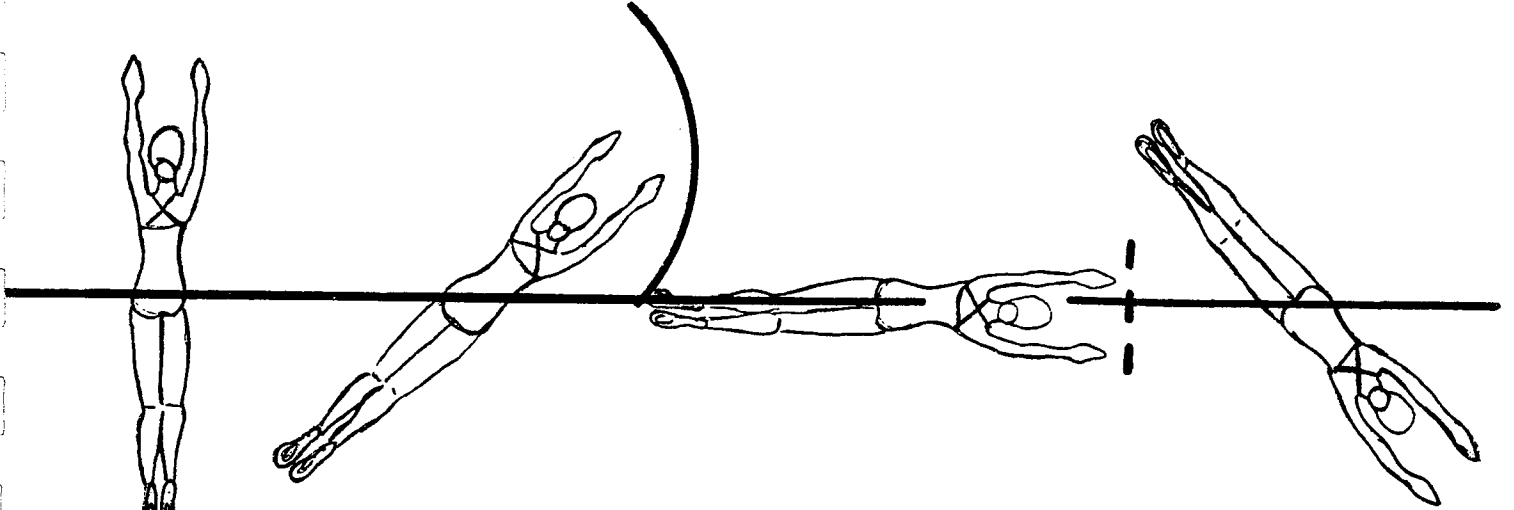

# FOUR KINDS OF ROTATION

## In/Out Rotation

TURN-IN OR TURN-OUT FROM THE  
HIP OR SHOULDER JOINTS

0 = Complete Turn-Out

1 = Partial Turn-Out

2 = Natural



3 = Partial Turn-In

4 = Complete Turn-In

## Axial Rotation

WHOLE BODY TURNS AROUND ONE CENTRAL  
AXIS (TURNS IN PLACE)



Slow-Inching Turns



Fast-Spinning Turns



Twisting of the Torso

## Joint - Circular Rotation

CIRCLES ARE PAINTED IN THE AIR  
BY THE EXTREMITIES-FOUR DIFFERENT  
CIRCLES ORIGINATING FROM FOUR  
DIFFERENT JOINTS

Hip and/or Shoulder (solid-lined symbol):



Knee and/or Elbow (dotted-lined symbol):



Ankle and/or Wrist (solid-lined symbol):



Toe and/or Finger (dotted-lined symbol):

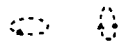

## Isolation-Circular Rotation

CIRCLES ARE PAINTED IN THE AIR  
BY DIFFERENT PARTS OF THE BODY-  
THE CIRCLES DO NOT NECESSARILY  
ORIGINATE FROM ANY JOINT

Shoulders:



Neck (Head):



Hips:



Ribcage Isolations:

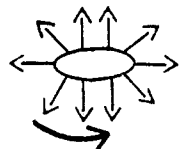

# JOINT-CIRCULAR ROTATION

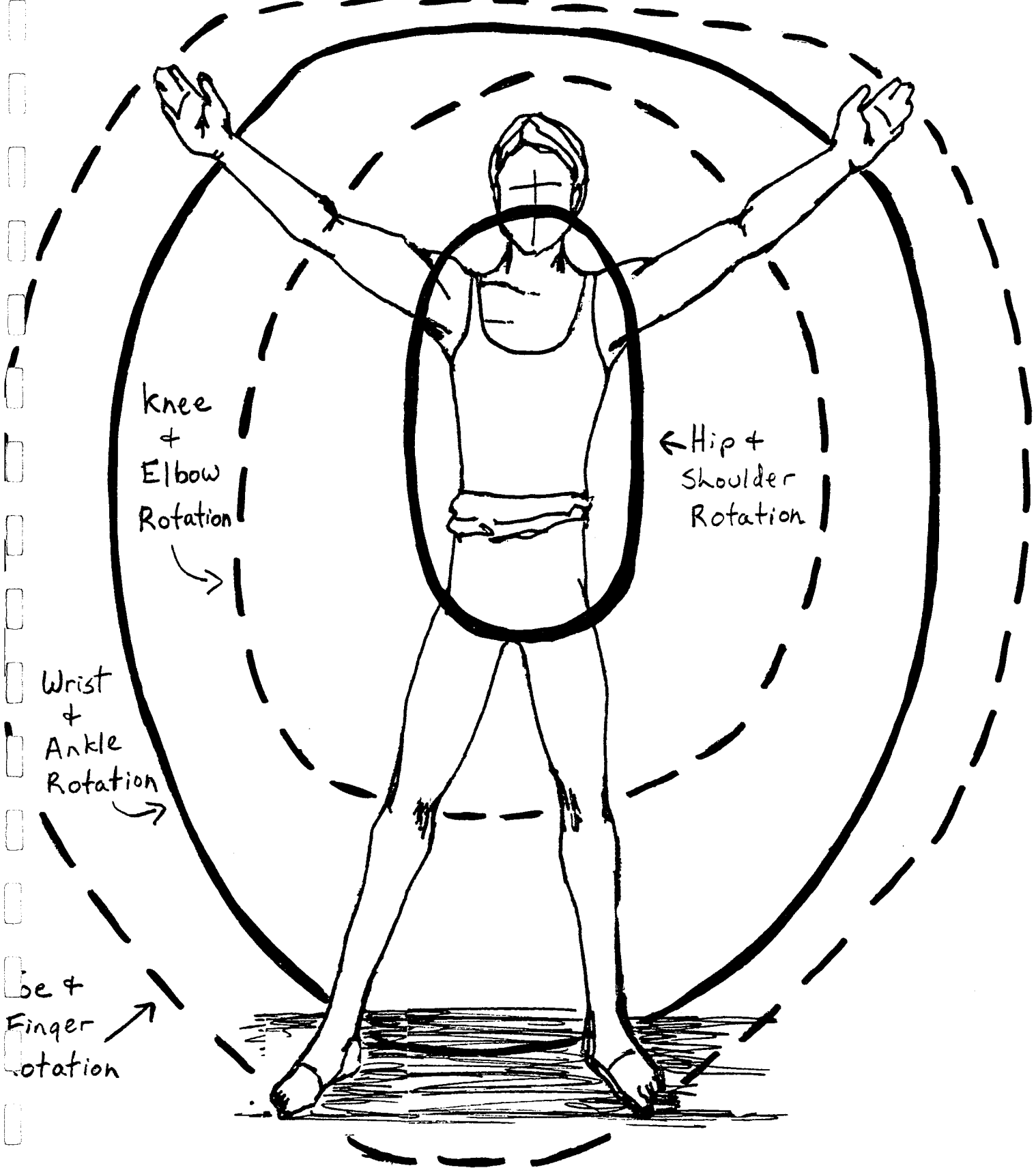

Copyright © 1977 by Valerie J. Sutton

All Rights Reserved

Pan American and Universal Copyrights Secured

# THE TRANSVERSE PLANE OF THE ROOM

1. The Transverse Plane cuts the room through the middle. The Transverse Plane is parallel with the floor and cuts the room from all sides. The Transverse Plane dissects the room into a lower and upper portion.
2. The best view of the Transverse Plane cutting the room is from overhead. The overhead view gives the complete picture of the Transverse Plane extending in all directions.
3. Many Movement Symbols are seen from the overhead view. They are viewed along the Transverse Plane of the room. All Movement Symbols that show movement parallel with the floor are viewed from the Transverse Plane.
4. The majority of Movement Symbols viewed from the Transverse Plane use the Body's Sagittal Line as their center line. Some examples of these symbols are:  
Circular Motion Symbols (Rond De Jambe Symbols)  
Fast-Spinning Turning Symbols (Pirouette Symbols)  
Traveling Symbols
5. Some Movement Symbols viewed from the Transverse Plane do not employ the Body's Sagittal Plane as a center line. Some examples of these symbols are:  
Slow-Inching Turning Symbols (Promenade Symbols)  
Walking and Running Dots

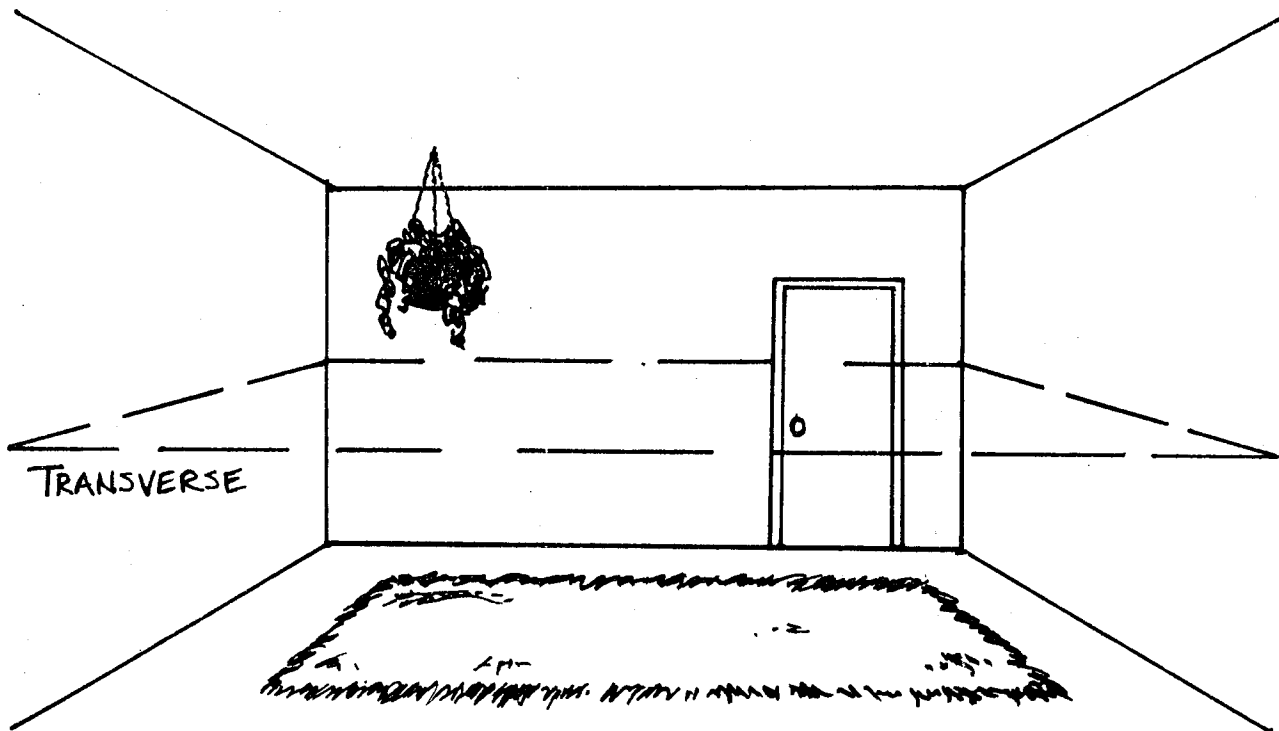

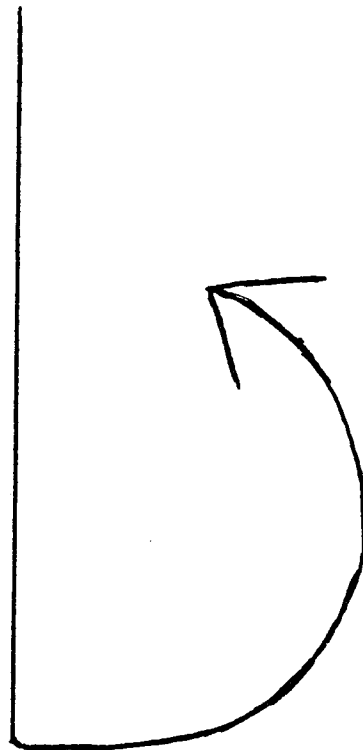
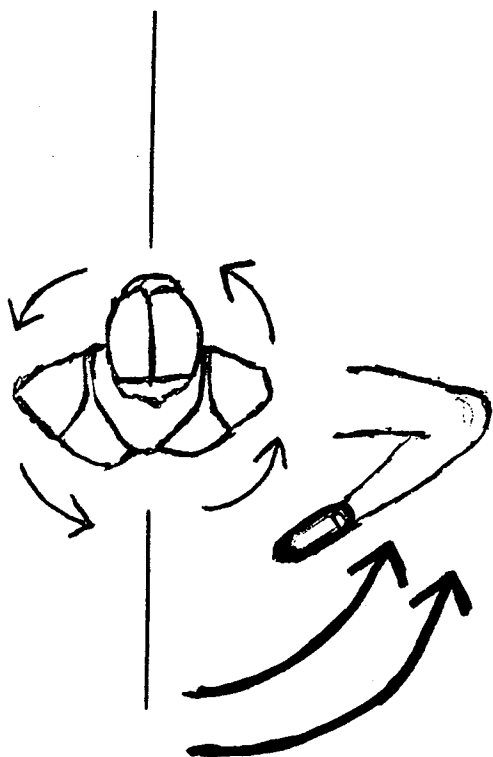
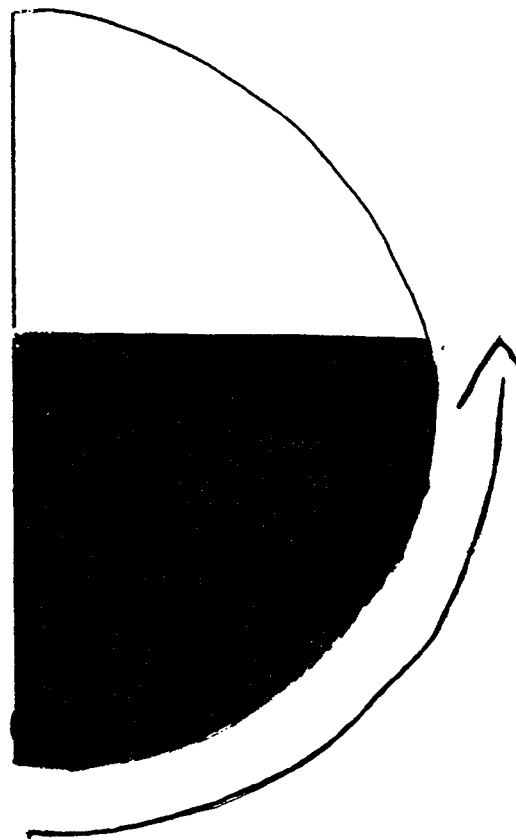
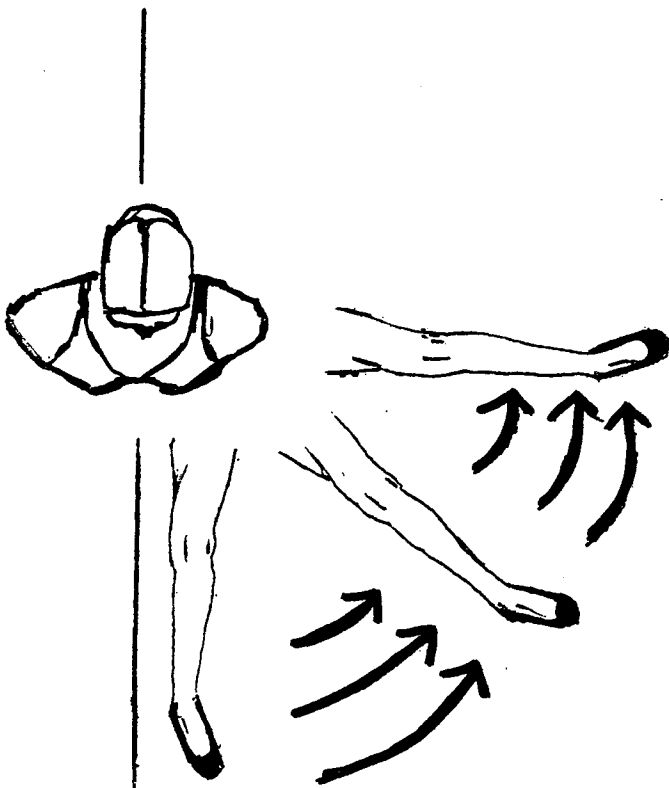

# CIRCLES IN PLACE

Circles that do not travel but remain on top of the figure's CENTER DOT are the Slow-Inching Turn and the Fast-Spinning Turn.

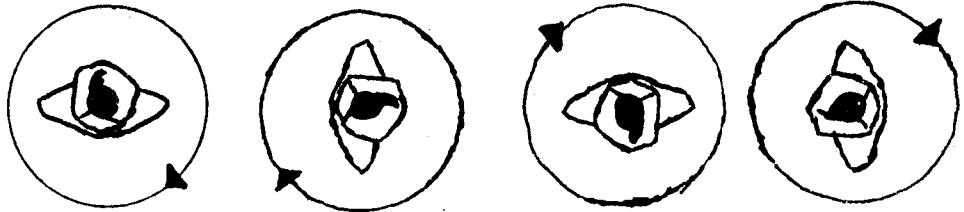

SLOW TURN

FAST TURN

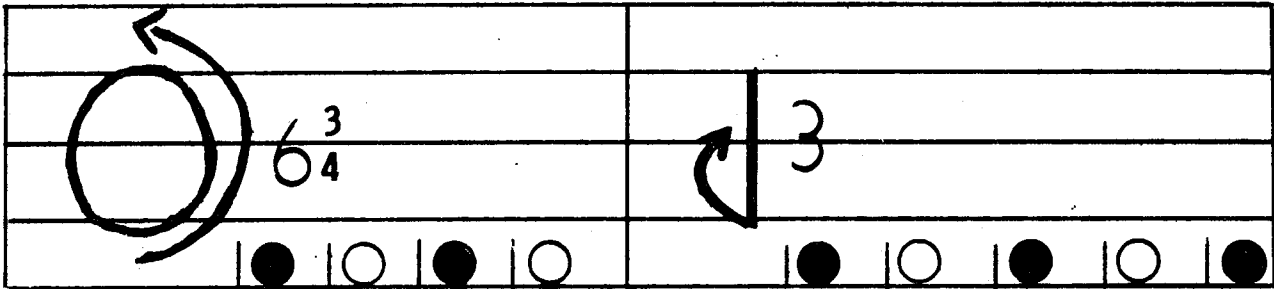

UNIT CONNECTING LINE

# TRAVELING CIRCLES

Circles that travel around an imaginary center dot (center of circle is in the middle of the circle, the person stands on the outside rim of the circle), employ the Slow-Inching Turn Symbol with Traveling Symbols attached.

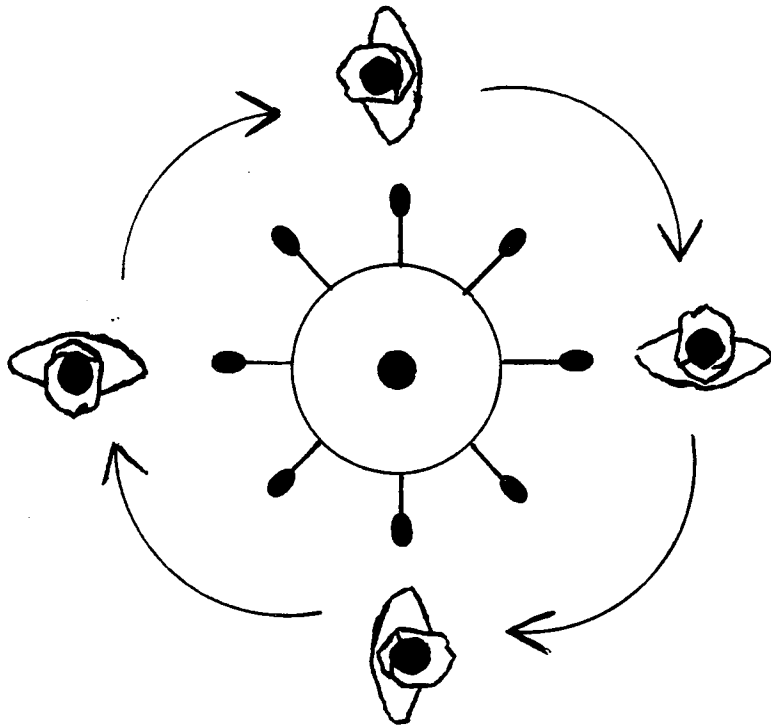

A musical staff with five horizontal lines. On the left side, a circle with eight spokes is positioned between the second and fourth lines. A curved arrow starts from the right side of the circle, loops around, and points back to the right side, with a vertical line and the number '1' next to it, indicating a turn. Below the staff, a horizontal line contains a sequence of ten circles: an open circle, a closed circle, an open circle, a closed circle, an open circle, a closed circle, an open circle, a closed circle, an open circle, and a closed circle.

UNIT CONNECTING LINE

# CIRCULAR MOTION ON THE ROOM'S FRONTAL PLANE

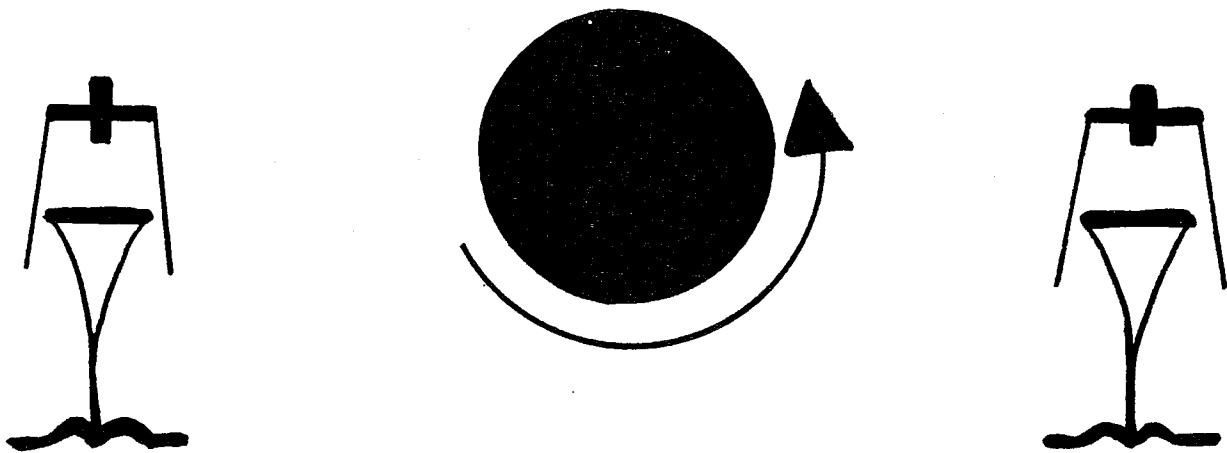
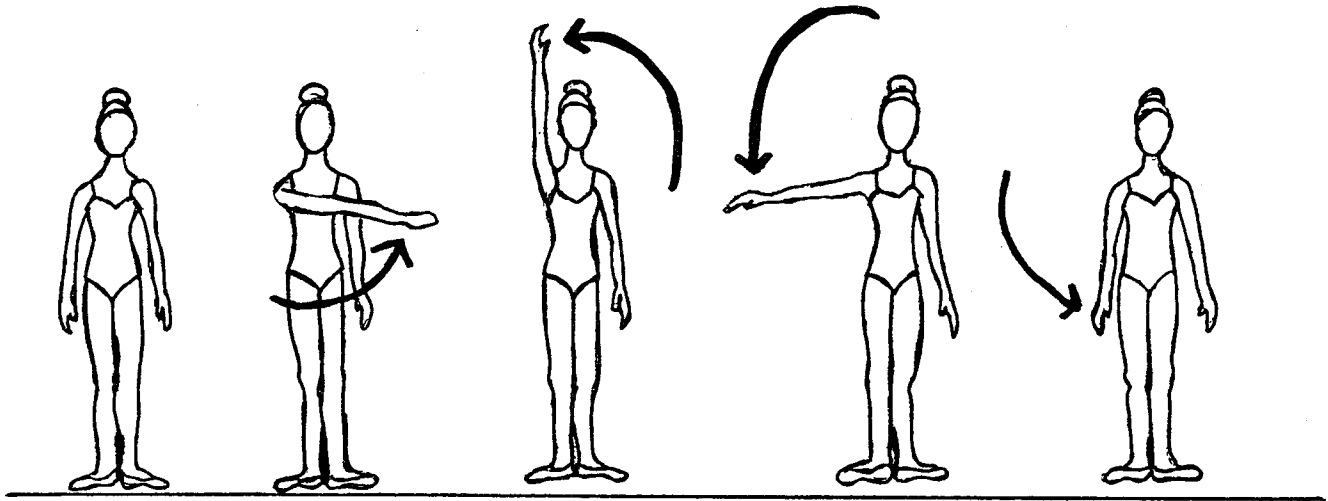



# CIRCULAR MOTION ON THE ROOM'S DIAGONAL PLANE

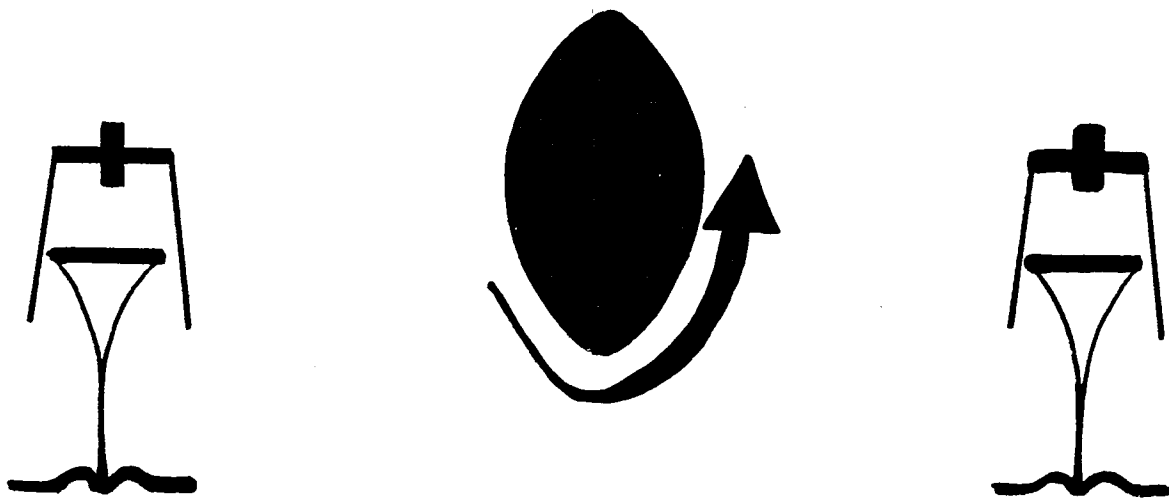
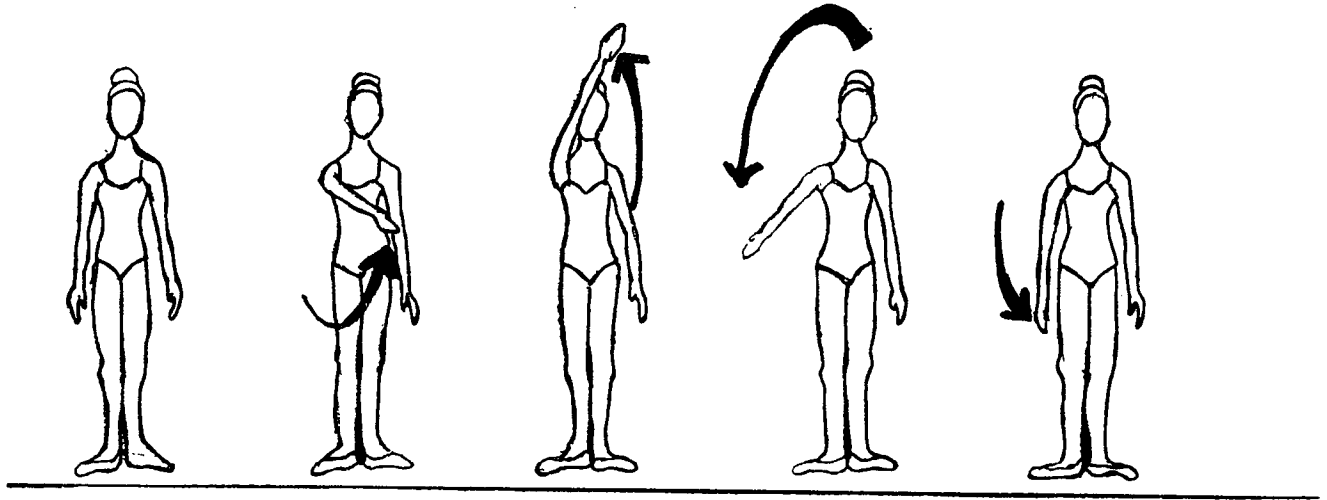

# CIRCULAR MOTION ON THE ROOM'S SAGITTAL PLANE

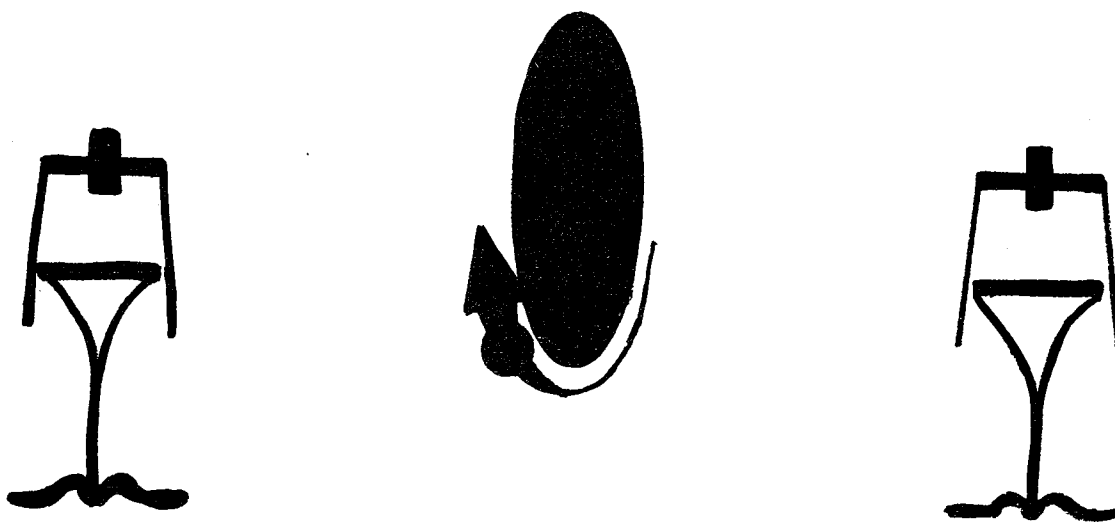
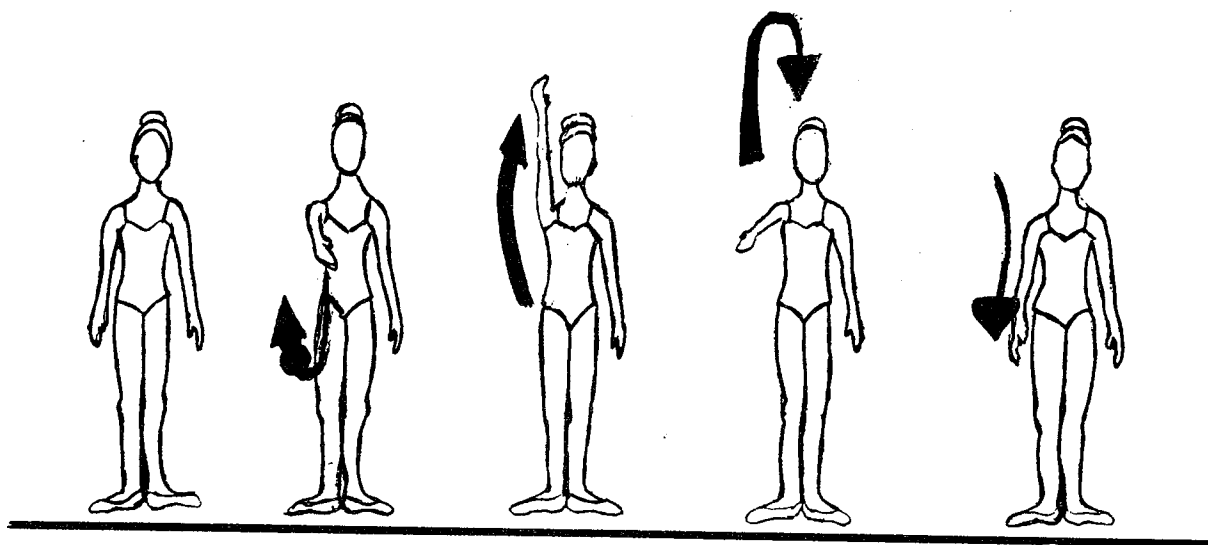

In/Out Rotation: Numbers placed underneath the Movement Staff beside Position Symbols:



Axial Rotation: Slow-Inching Turn Symbol placed between two figures:

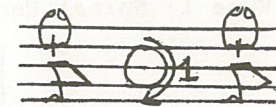

Fast-Spinning Turn Symbol placed between two figures:

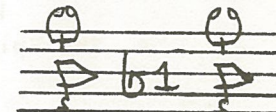

Twisting Arrows placed as a unit with one figure:



Joint-Circular Rotation: Hip/Shoulder Circular Rotation Symbol placed between two figures:

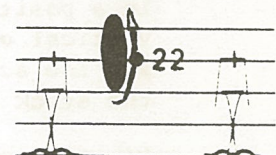

Knee/Elbow Circular Rotation Symbol placed as a unit with one figure:

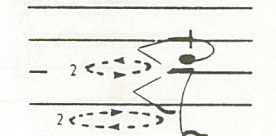

Ankle/Wrist Circular Rotation Symbol placed as a unit with one figure:

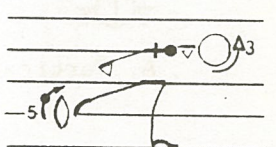

Toe/Finger Circular Rotation placed as a unit with one figure:

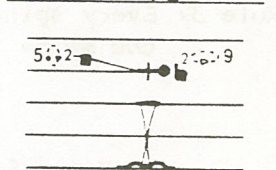

Isolation Circular Rotation: All symbols in this category are placed between two figures:

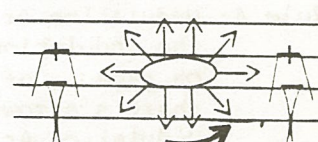
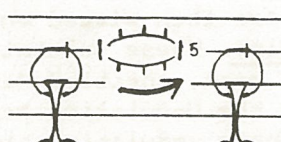
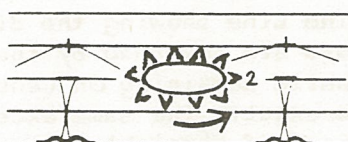
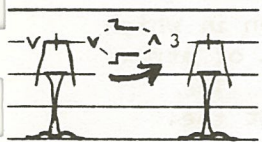

CIRCULAR ROTATION - RIGHT/LEFT/BOTH



Right



Left



Both

CIRCULAR ROTATION - SMALL/MEDIUM/LARGE



Small



Medium

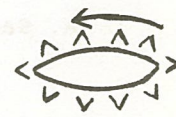

Large

SPINAL UNDULATIONS

Rule 1: Spinal Undulation Symbols consist of:

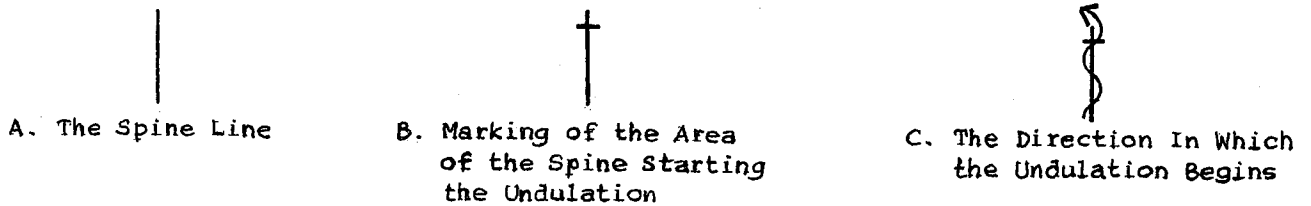

Rule 2: The Spine Line is always drawn vertically. Whether the spinal undulation is executed with the spine in a vertical position, in a horizontal position, or in a position between vertical and horizontal, the Spine Line will remain vertical on the Movement Staff. The Spine Line represents the spine in general, and the actual vertical or horizontal positioning of the spine is notated in the stick figures directly before and after the Spinal Undulation Symbol:

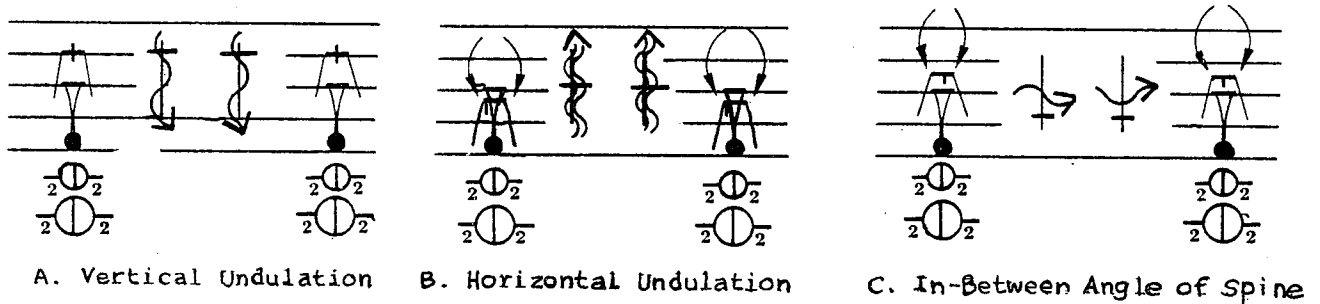

Rule 3: Every spinal undulation begins at a specific part of the spine. This section of the spine is marked with a small line perpendicular to the Spine Line:

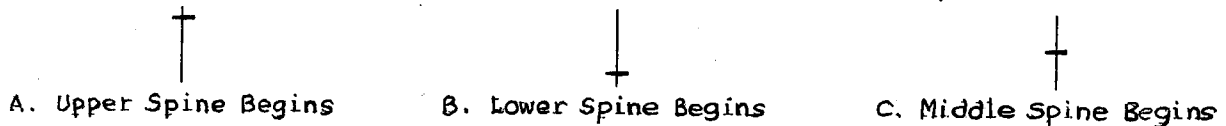

Rule 4: Undulation Arrows are then placed on the Spine Line showing the direction in which the undulation begins. These Undulation Arrows are governed by the chart of arrows on page of this book, entitled Movement While Remaining On Center Dot. The chart's arrows and the Undulation Arrows are exactly the same except that the Undulation Arrows have undulating stems instead of straight stems:

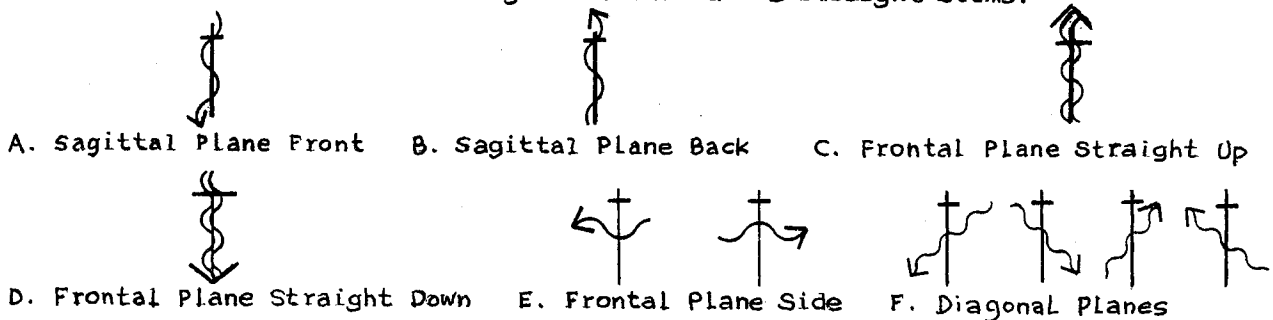

# TRAVELING ALONG BODY PLANES

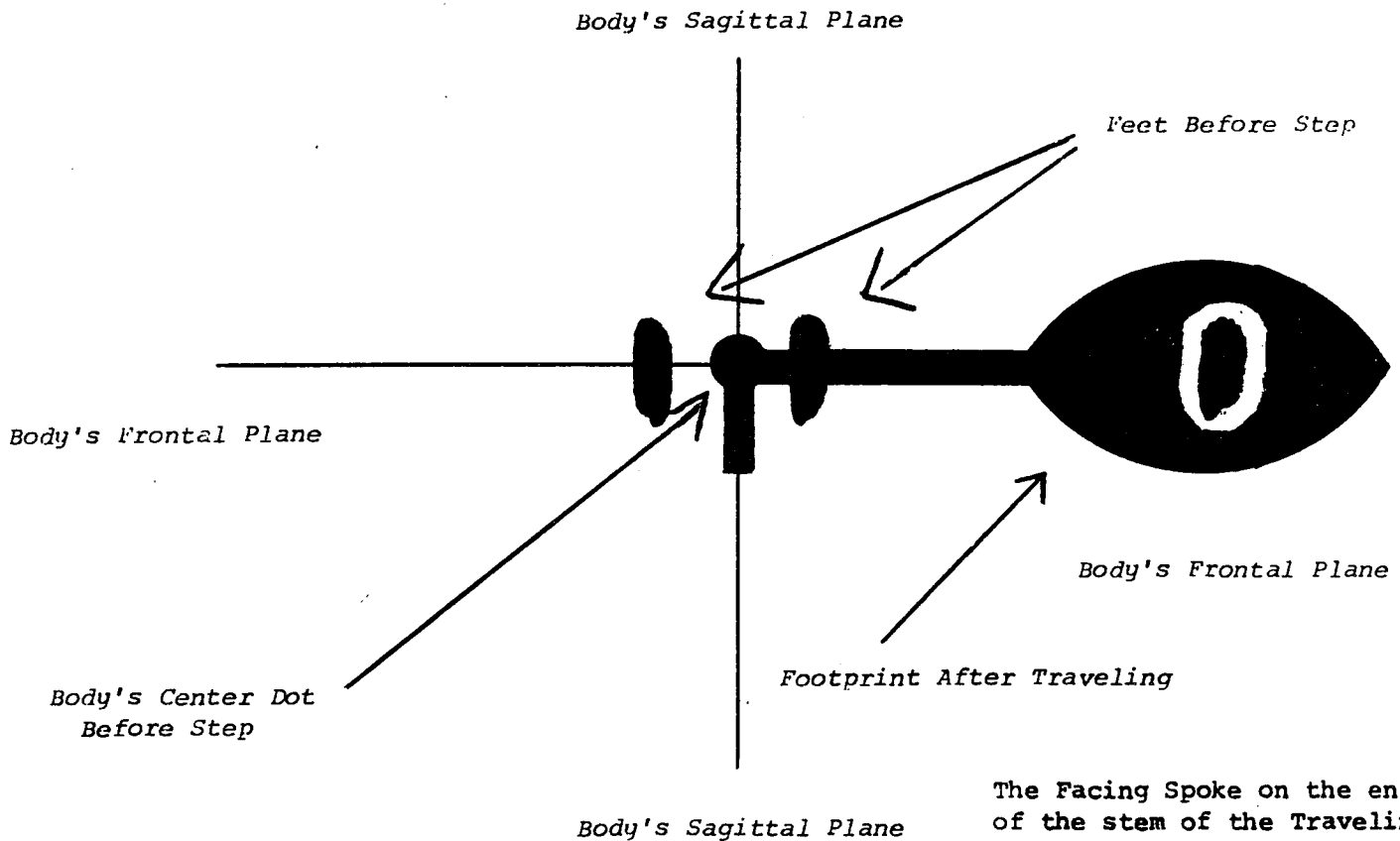
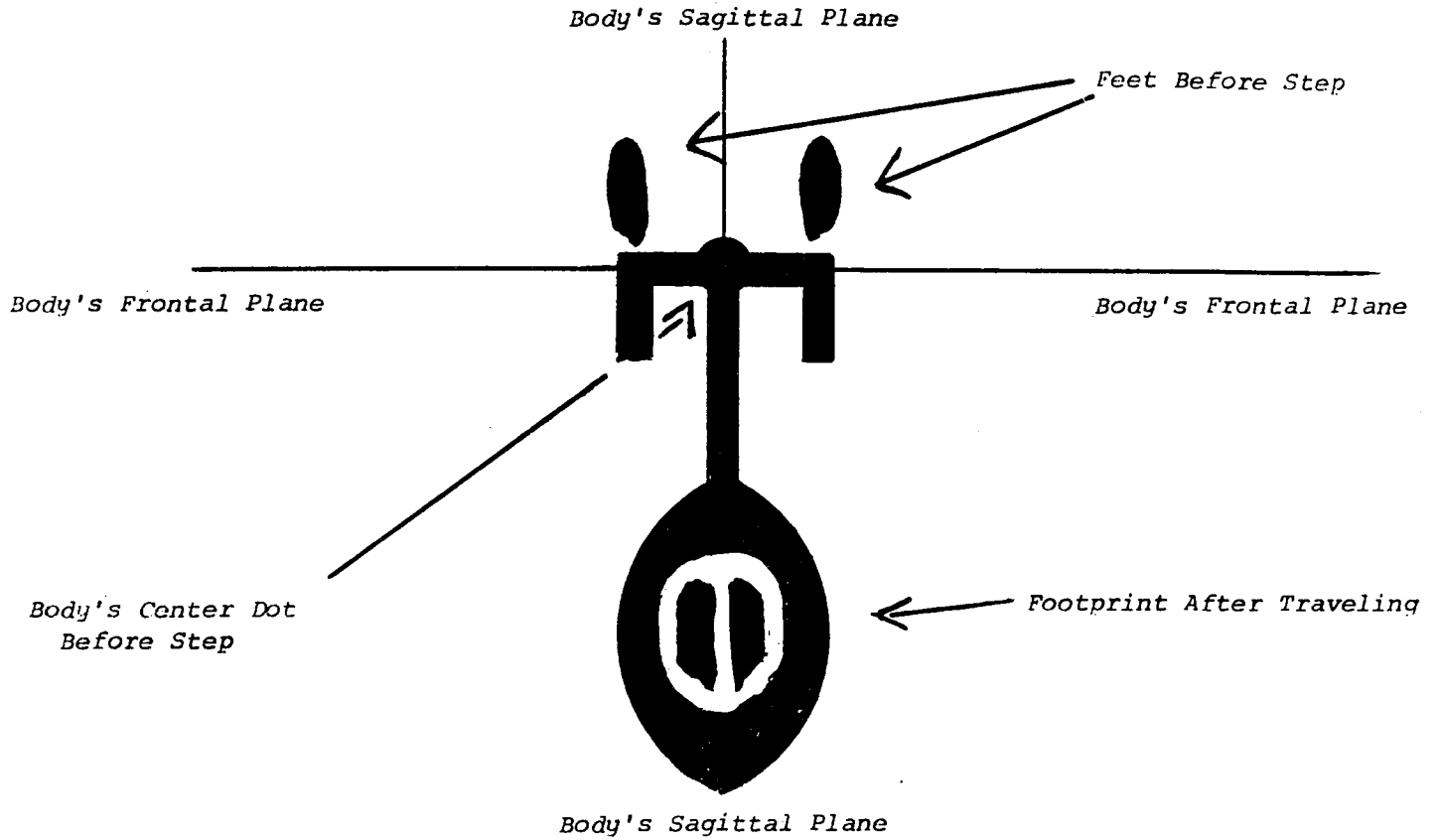

The Facing Spoke on the end of the stem of the Traveling Symbol is always parallel with the lower body's Sagittal Plane (shows where the hips and lower body is facing).

# MOVEMENT AWAY FROM CENTER DOT

Back Corner  
Diagonal Plane

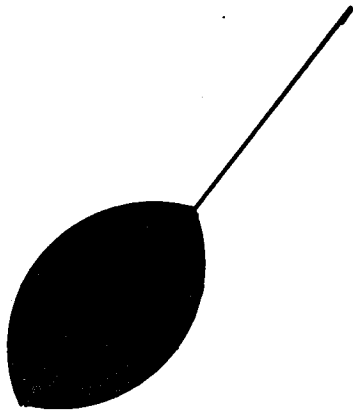

Back Wall  
Sagittal Plane

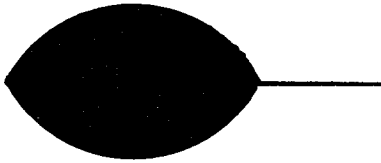

Back Corner  
Diagonal Plane

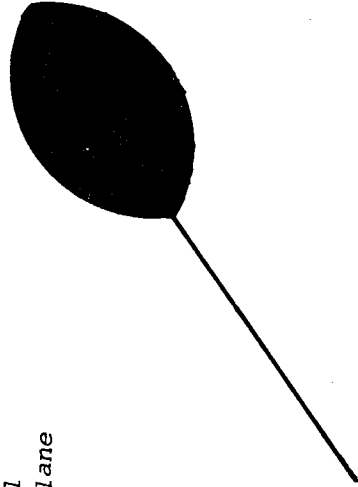

Traveling Up  
From Center Dot

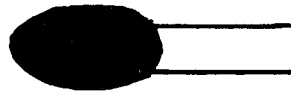

Side Wall  
Frontal Plane

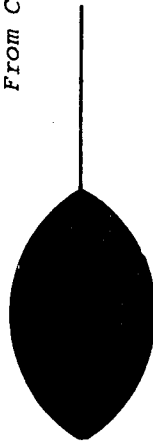

Traveling Down  
From Center Dot



Side Wall  
Frontal Plane

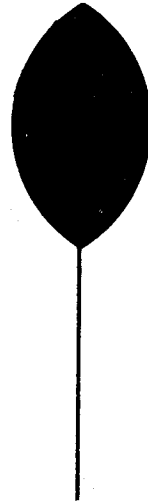

Front Corner  
Diagonal Plane

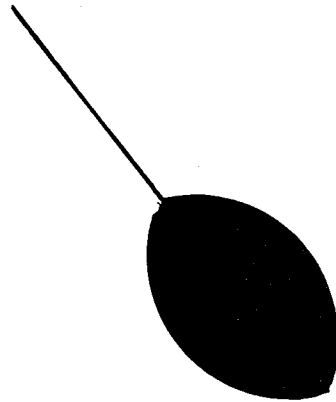

Front Wall  
Sagittal Plane

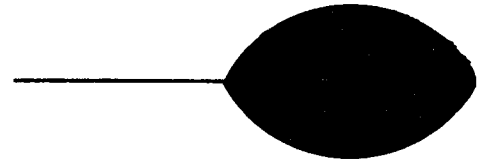

Front Corner  
Diagonal Plane

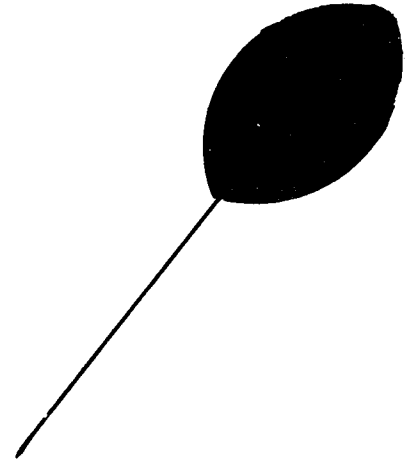

Following the same principles as In-Out Position Symbols, Traveling Symbols can show whether a traveling movement is close to the CENTER DOT or far from the CENTER DOT of the previous position.

Light Traveling Symbols represent a traveling movement that is close to where the movement started. They notate short, or small steps. Light Traveling Symbols represent traveling movement within the knee-range of the original CENTER DOT.

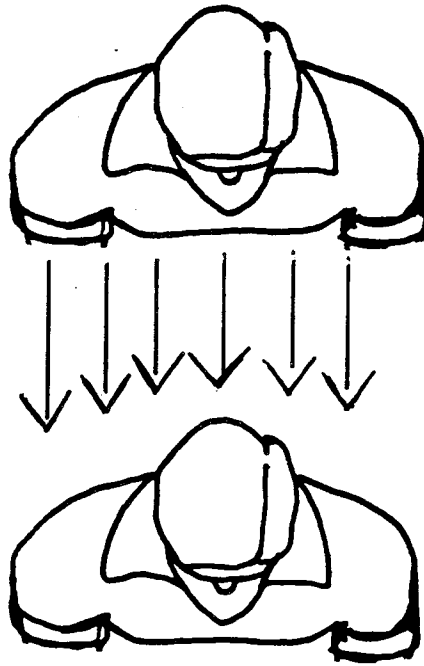

Dark Traveling Symbols represent a traveling movement that is far from where the travel started. They notate long, or large steps. The dark Traveling Symbols represent traveling movement outside the knee-range of the original CENTER DOT. The same "cylinder" principle used for In-Out Position Symbols is also used for Traveling Symbols.

\*Note: The Close and Far Traveling Symbols are exactly the same size although they represent different lengths of travel. They are always two spaces high, placed between the Knee Line and Shoulder Line of the Movement Staff.

One symbol is shown larger in these diagrams for visual purposes only.

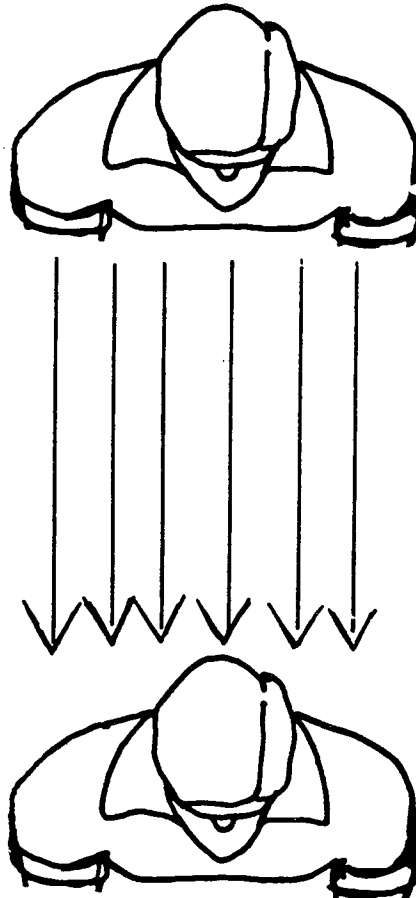

# MOVEMENT AWAY FROM CENTER DOT

## TRAVELING

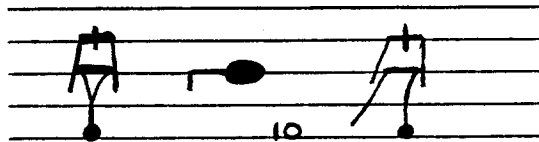
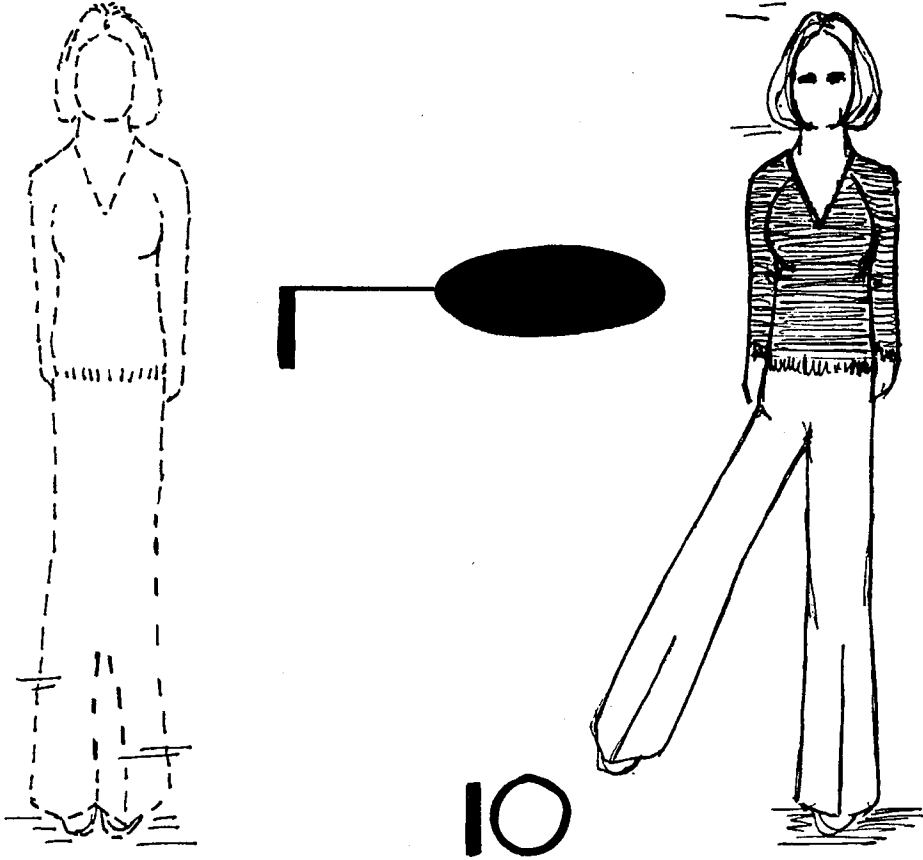



# WALKING ON FLAT FEET

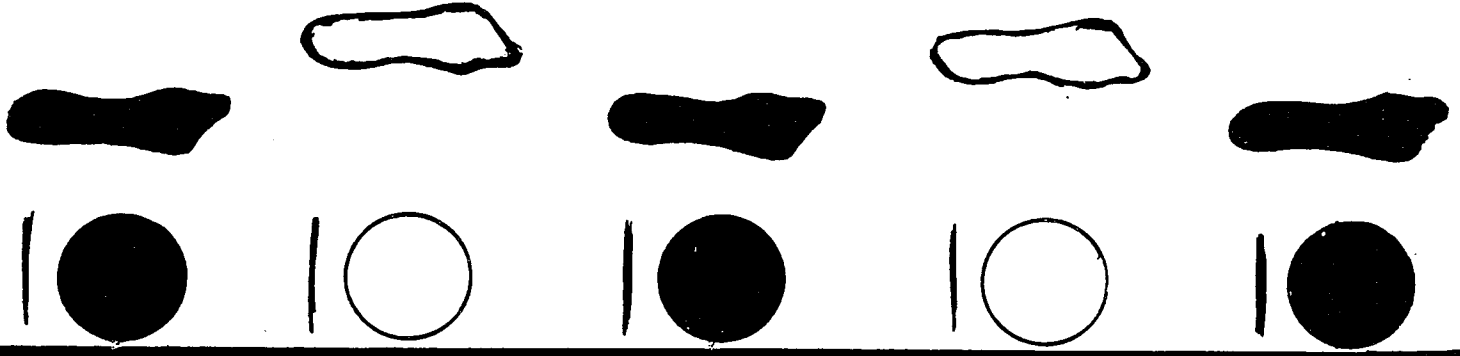

# WALKING ON BALLS OF FEET

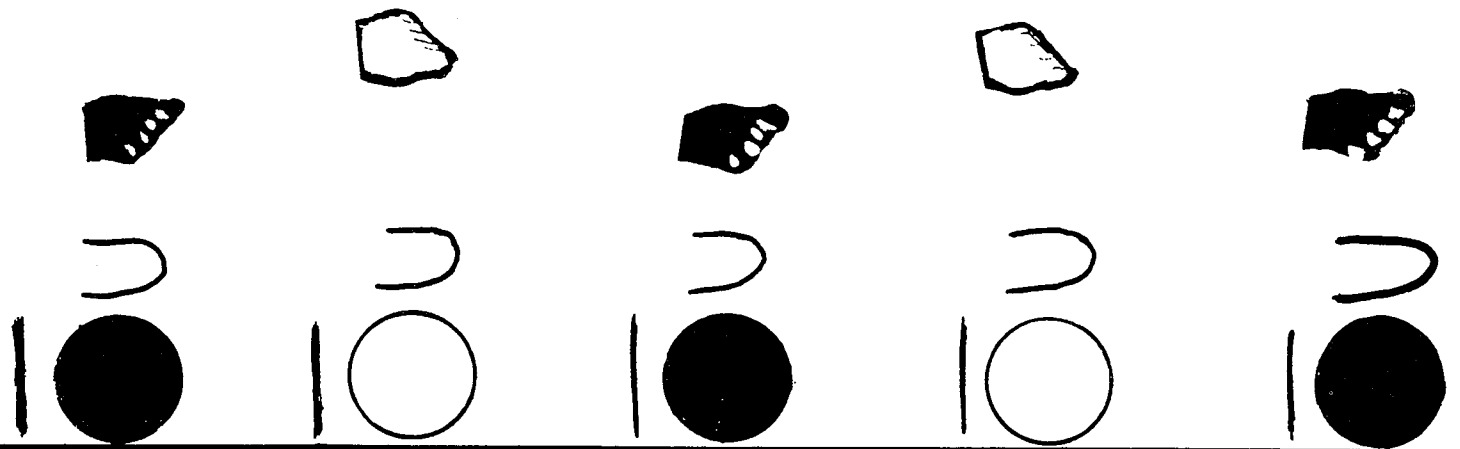

# WALKING ON TIPS OF TOES

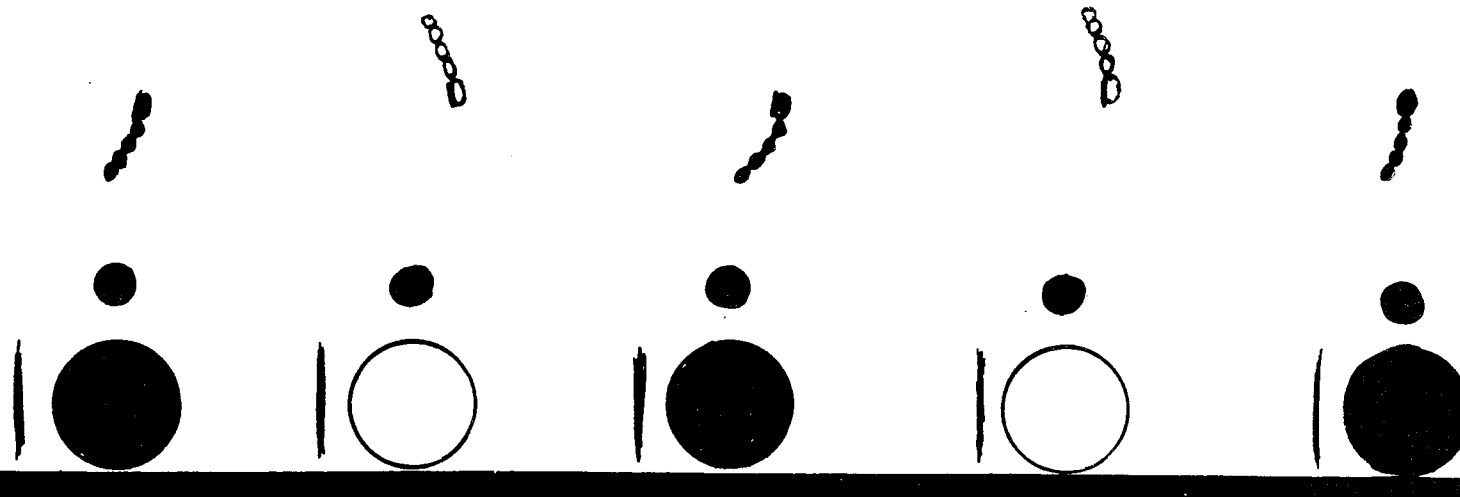

# MOVEMENT AWAY FROM CENTER DOT

## UNIT TILTS

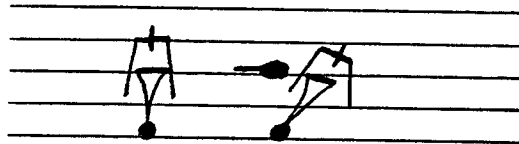
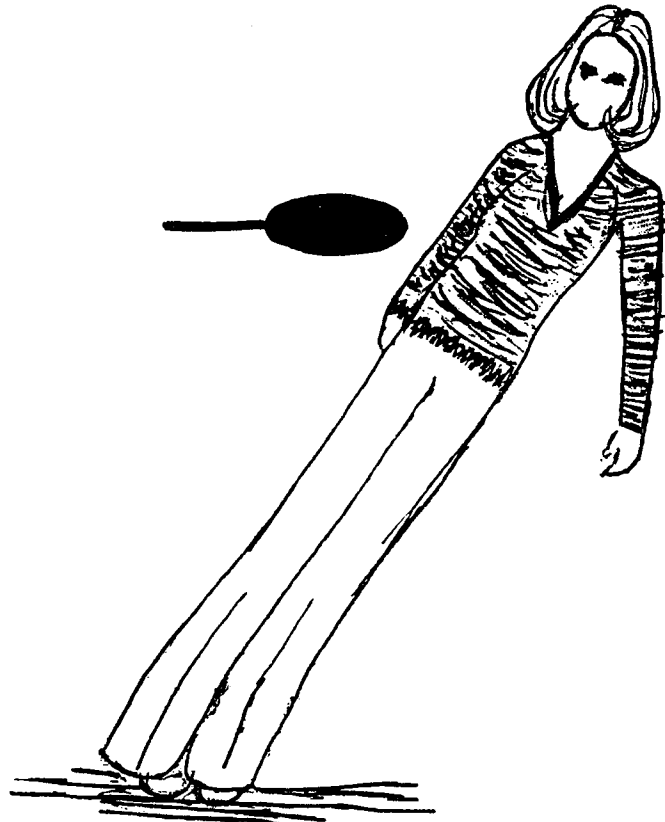
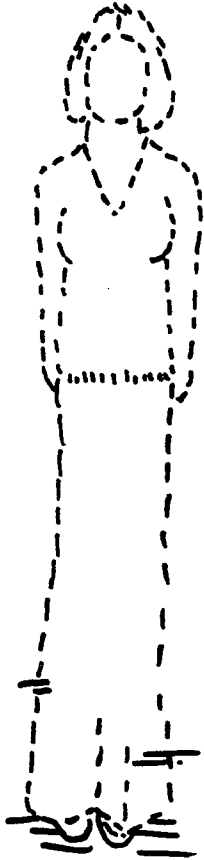

# UNIT TILTS

FACING ALL DIRECTIONS

TILT  
FORWARD

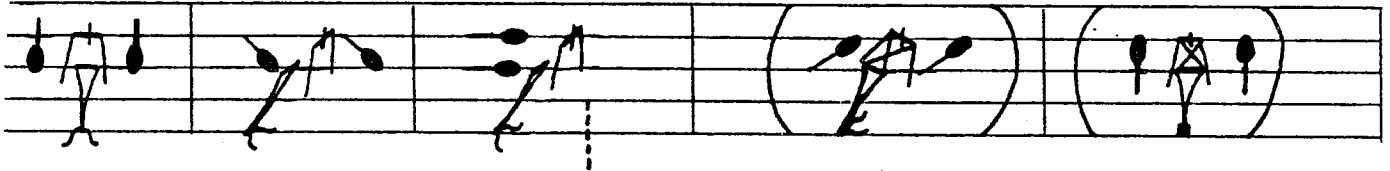

TILT  
DIAGONALLY

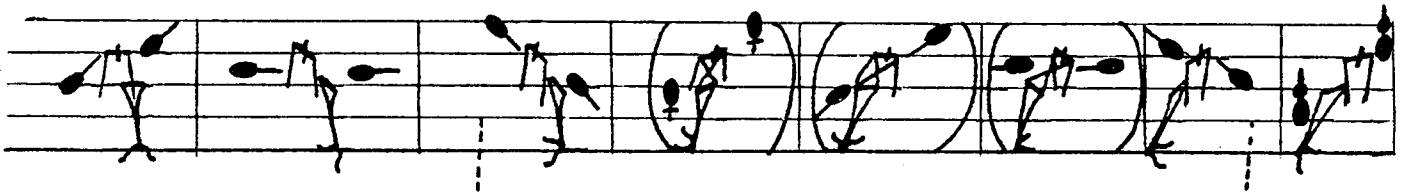

TILT  
SIDEWAYS



TILT  
BACKWARD

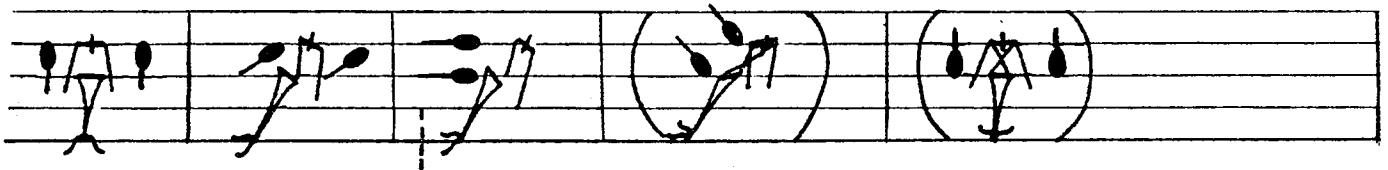

# MOVEMENT AWAY FROM CENTER DOT

1. Falling In Place, On Top Of The Center Dot:

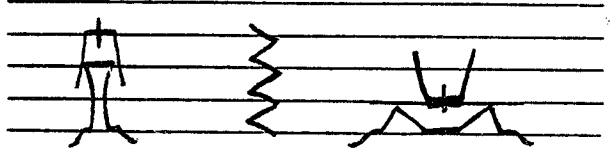

2. Falling Out, Forward On The Sagittal Plane Of The Room:

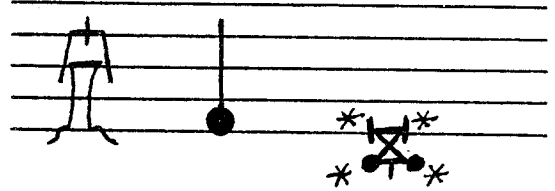

3. Falling Out, On The Diagonal Plane Of The Room:

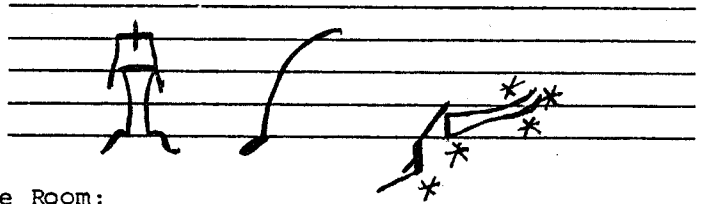

4. Falling Out, On The Frontal Plane Of The Room:



5. Falling Out, On The Diagonal Plane Of The Room:

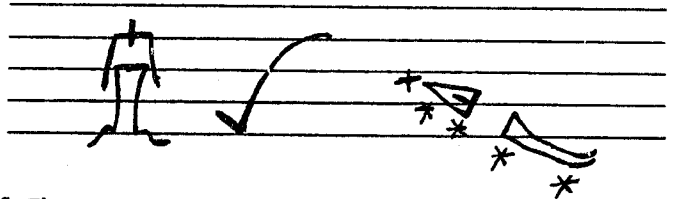

6. Falling Out, Back On The Sagittal Plane Of The Room:

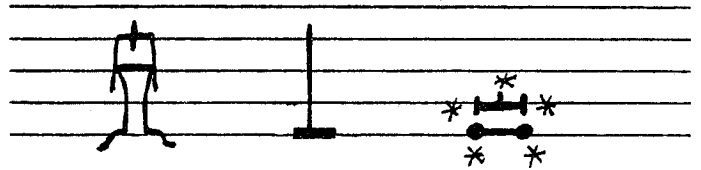

7. Falling Out, On An In-Between Plane Of The Room:

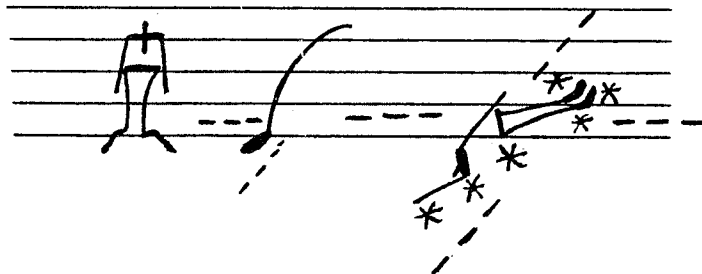

# WEIGHT ARROWS

When the stick figure is drawn with feet, hands, or the whole body on the Foot Line (the ground), we assume that even weight is on all parts of the body contacting the Foot Line. No special notation is placed on or under the figure when notating evenly-distributed weight:

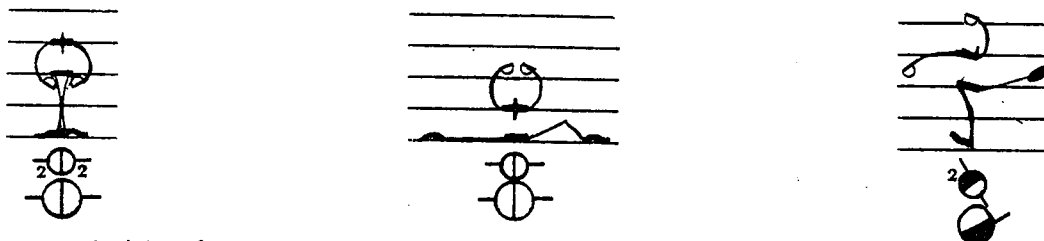

When weight shifts to one part of the body while another part of the body is still touching the ground, the weight is no longer evenly distributed. When uneven weight occurs in Sutton Movement Writing, two little Weight Arrows are placed under the Foot Line under the parts of the body shifting weight. These Weight Arrows act as a pulley. The Weight Arrow pointing down pulls the weight down into the ground. The Weight Arrow pointing up loosens the weight from the part of the body to which it points.

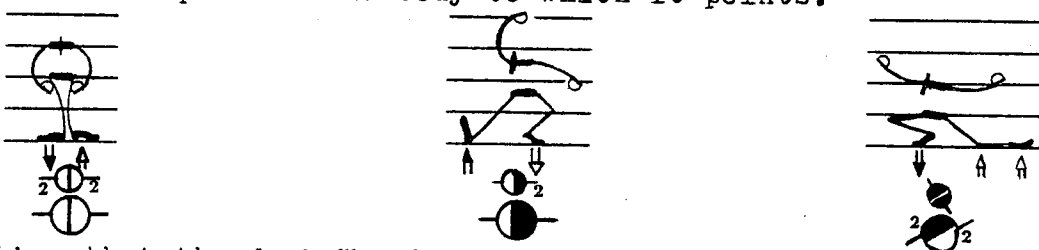

Notice that the dark Weight Arrow corresponds to the right leg or right side of the body. The Weight Arrow that is light corresponds to the left leg or left side of the body.

Even with the Weight Arrows the stick figure must still be drawn so that the figure looks as if the weight is unevenly distributed.

In some Transitory Positions, as in glissade and jumps, there may be figures with both feet on the ground but with absolutely no weight on either of them. In these cases, both Weight Arrows point up.

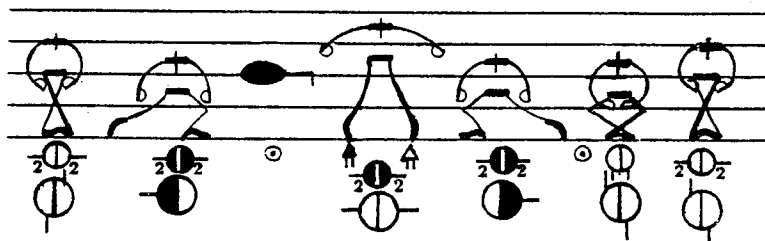

There are cases in modern ballet and modern dance where the weight is on one leg but the dancer is purposely off balance. The Weight Arrows are also used for certain off-balance positions. Again, the Weight Arrow is like a pulley, pulling the weight in the proper direction. In off-balance positions, the Weight Arrow points down, but at an angle, so that it is in line with the standing leg's angle.



# WEIGHT SHIFTS REMAINING ON CENTER DOT

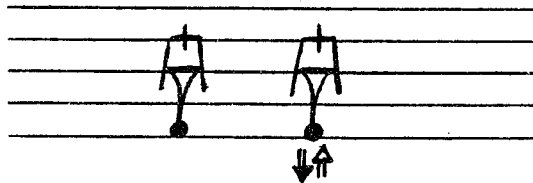
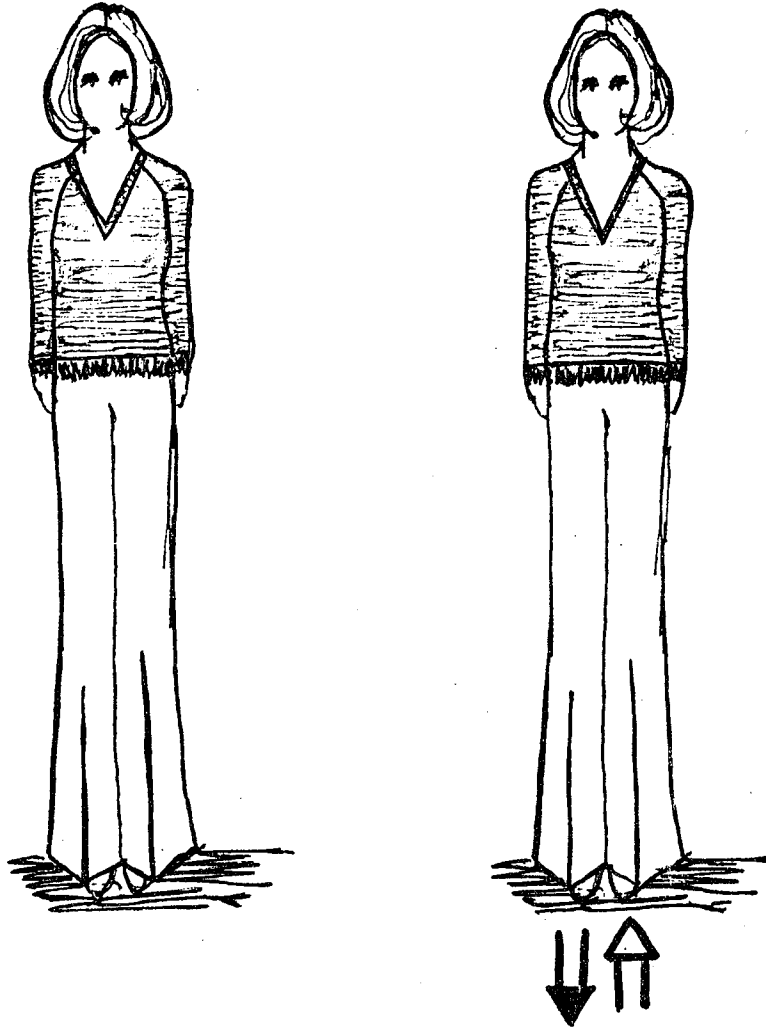

# WEIGHT SHIFTS MOVEMENT AWAY FROM CENTER DOT

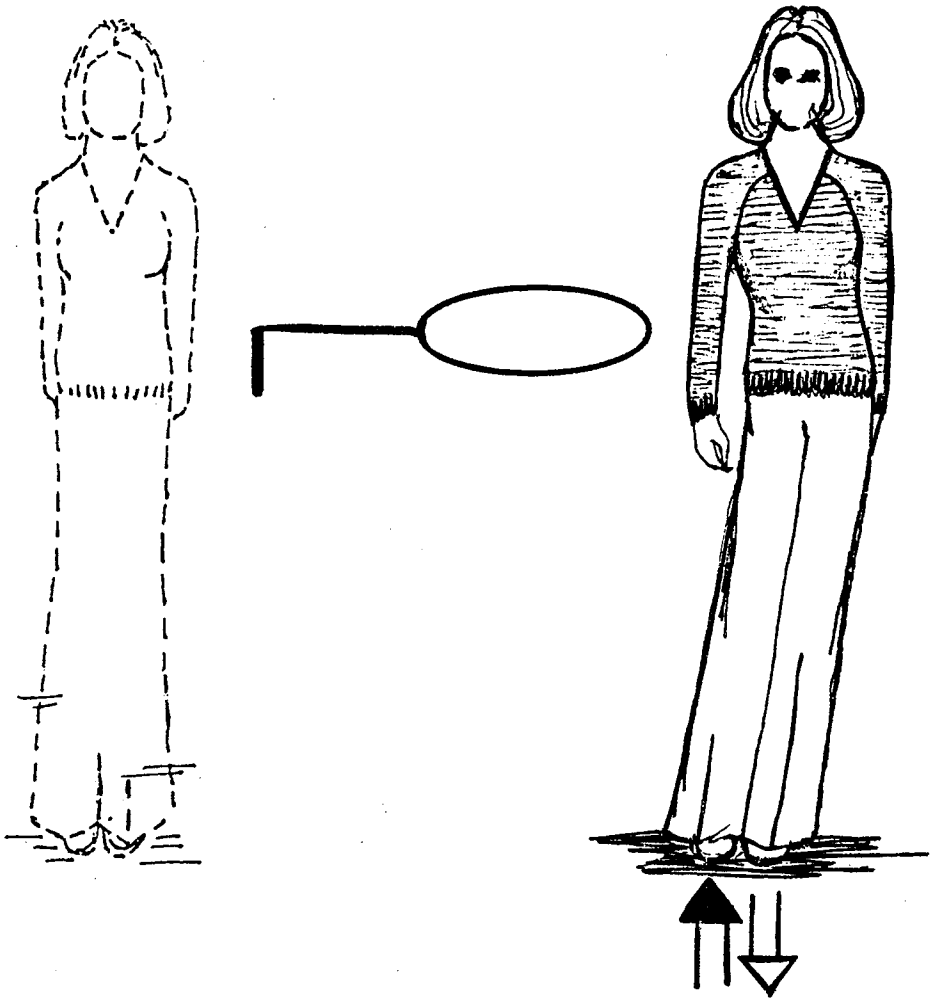

THE TRANSITORY-ELIMINATION LINE

When a movement is executed over many counts or beats, there are two ways to notate the movement. The movement can be broken down into many positions and a position is written under each count or a Transitory-Elimination Line can be used in place of the many positions, showing only the first and last figures:

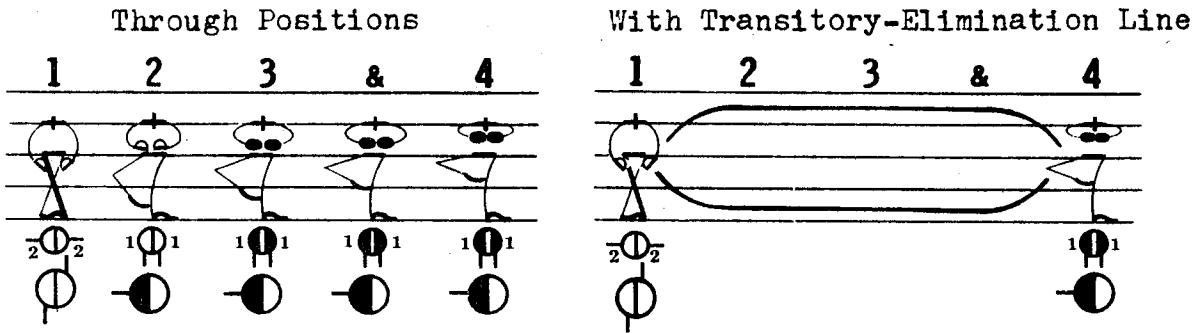

Breaking the movement down into positions is preferred when the positions are easily drawn. But there are times when a movement is almost impossible to draw through many positions. It is in these cases that the Transitory-Elimination Lines are used (see below):

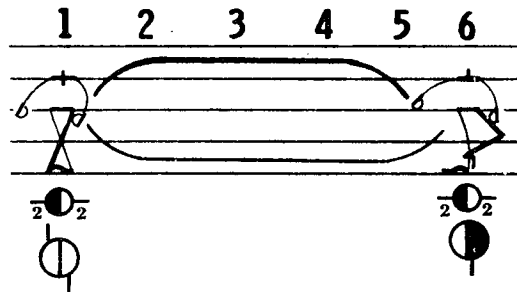

The Transitory-Elimination Line for the lower body is always placed between the Foot Line and Hip Line of the Staff. The Transitory-Elimination Line for the upper body is always placed between the Hip Line and Top Line of the Staff.

It is therefore possible to just use the Transitory-Elimination Line for the upper body, or just use the Transitory-Elimination Line for the lower body when necessary:

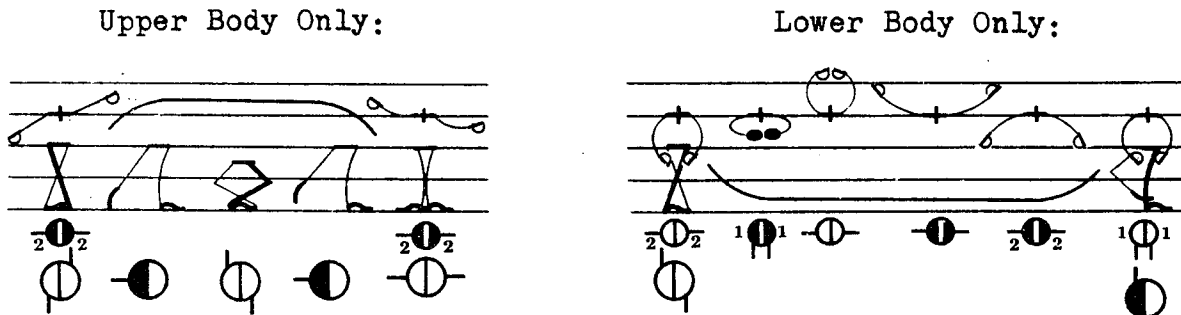

\*Note: The Transitory-Elimination Line is commonly called the Gradual-Position Line or just "The Gradual Line". Although the Transitory-Elimination Line notates gradual movement, it can only be used for eliminating Transitory Positions. It only eliminates stick figures, not Movement Symbols. It does not notate Smooth Movement (see next page for Smooth Line). It connects figures with a steady, evenly paced flow.



- Smooth Line (Curve Under Staff):
- Unit Connecting Line (Bracket Under Staff):
- Gradual Position Line (Curve Inside Staff):   
(Between Figures)
- Simultaneous Movement Line (Inside Staff):   
(Between Movement Symbols)
- Holding A Position (If half body holds, write again)  
(If whole body holds, leave space after)
- Continuing A Movement (Space After Movement Symbol)
- Staccato Movement (Dot Over Staff): ●
- Accented Movement (Accent Over Staff): >
- Sustained Movement (Fermata Over Staff):
- Unevenly Accented Movement (Grace Note Over Staff):
- Forceful Movement ("F" Over Staff): *fff*
- Peaceful Movement ("P" Over Staff): *ppp*
- Increasing Forcefulness (Crescendo Over Staff):
- Increasing Peacefulness (Decrescendo Over Staff):
- Moderately Forceful ("MF" Over Staff): *mf*
- Moderately Peaceful ("MP" Over Staff): *mp*
- Dynamic Words (Descriptive Words Over Staff): *agitato*

1. When two movements happen simultaneously they are either A. Placed on top of each other so that the first symbol is over the beginning of the second symbol, both connected by the Unit Connecting Line below the Staff or B. The symbols are placed side by side with the Simultaneous Line connecting them.

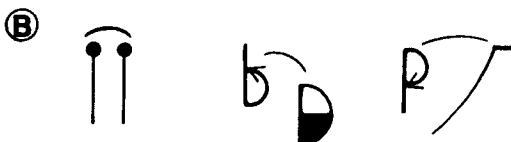
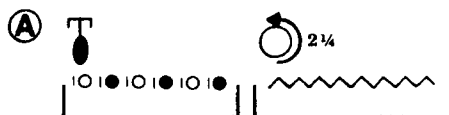

2. When two movements happen at different times the first movement to occur is placed first on the Staff, the second directly to its right. No line connects them. The movements are read sequentially.

3. Smooth Lines and Unit Connecting Lines are always placed under the Staff. If the Smooth or Unit Lines are placed under the Position Symbols for the upper body only, then only the upper body is moving smoothly or in a unit. If the Smooth or Unit Lines are placed under the Position Symbols for the lower body only, then only the lower body is moving smoothly or in a unit. To notate both the upper body and the lower body moving smoothly or in a unit two Smooth or Unit Lines must appear under the Staff, one under the first row of Position Symbols and one under the second row of Position Symbols:

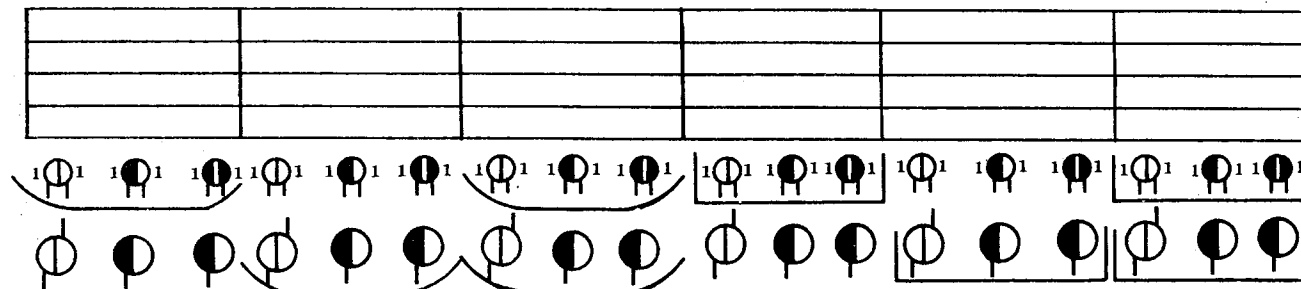

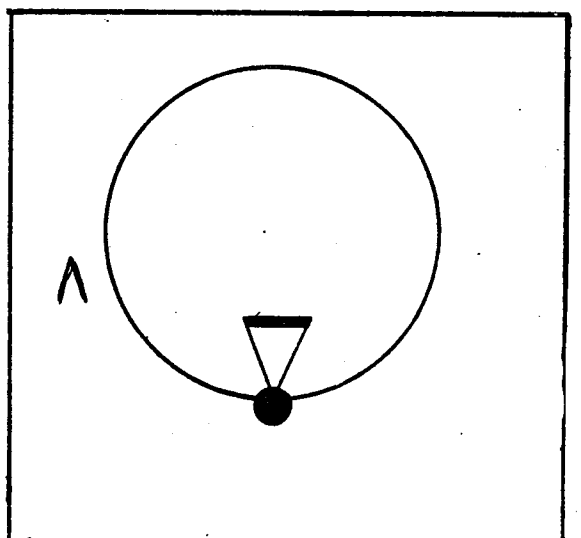
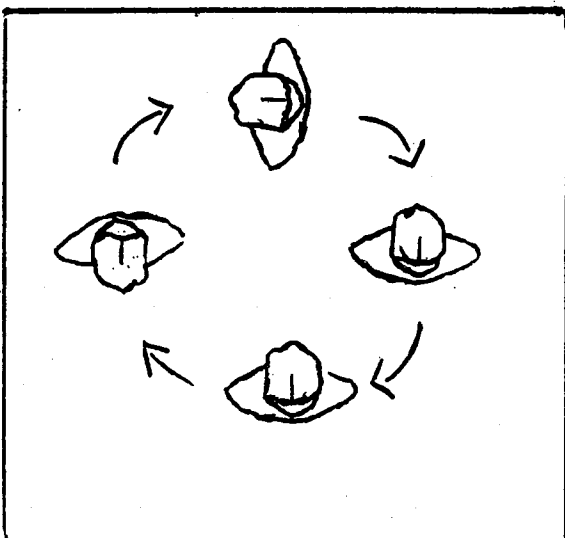
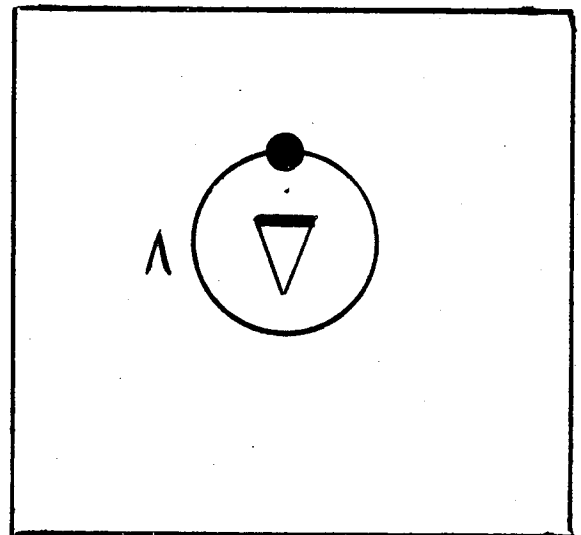
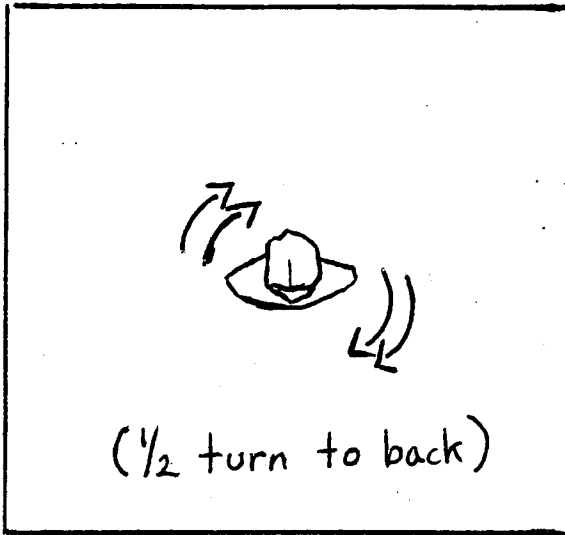
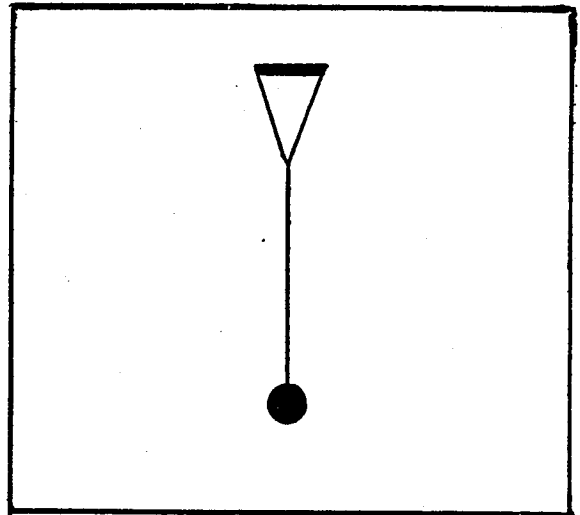
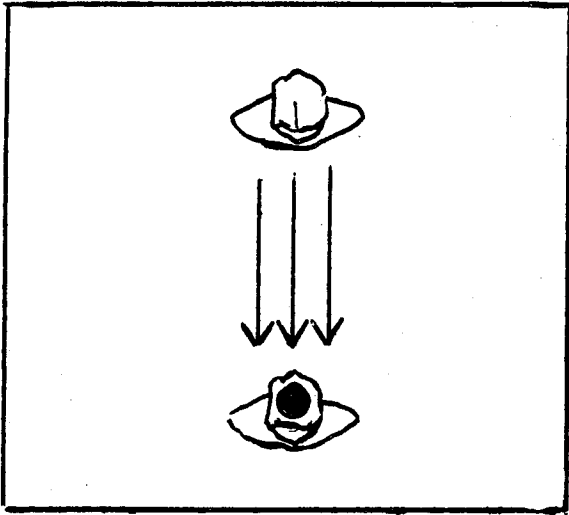

# PATTERNS

1. The triangle in the Pattern Stage represents the placement on stage of the first stick figure on the Movement Staff.
2. The triangle points in the direction the first stick figure on the Staff faces.
3. The triangle is light for female, dark for male, and two-sided for either.
4. The dot in the Pattern Stage represents the placement on stage of the last stick figure on the Movement Staff.

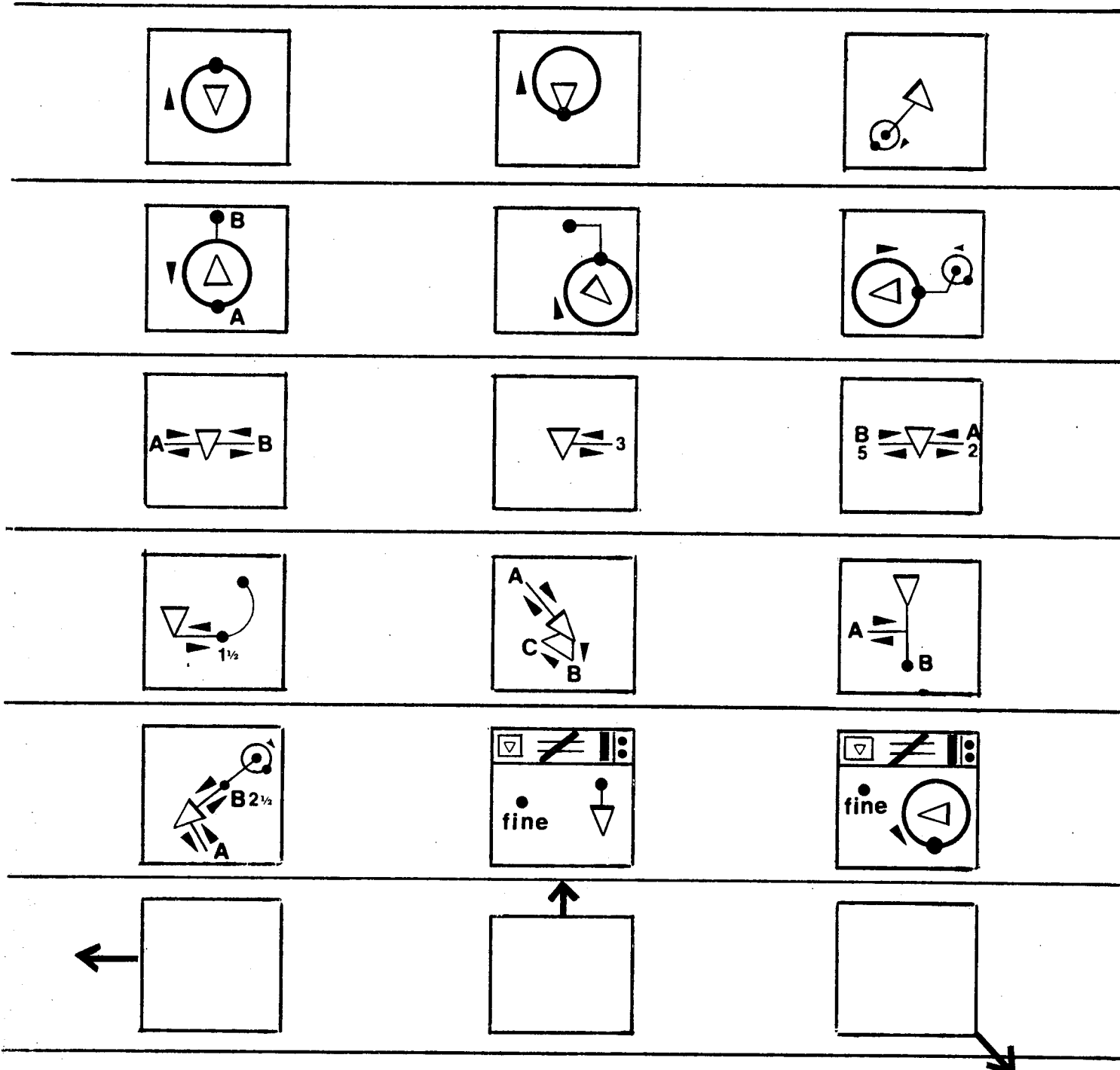

5. The pattern line between the triangle and the dot represents the pattern of movement on the stage between the first and last stick figures on the Staff. There can be no traveling pattern without Traveling Symbols in the notation to the right.

# SPECIAL INFORMATION BOXES

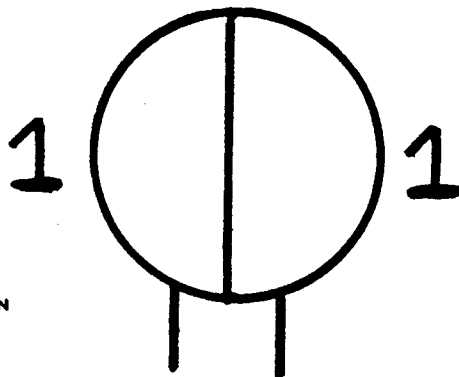
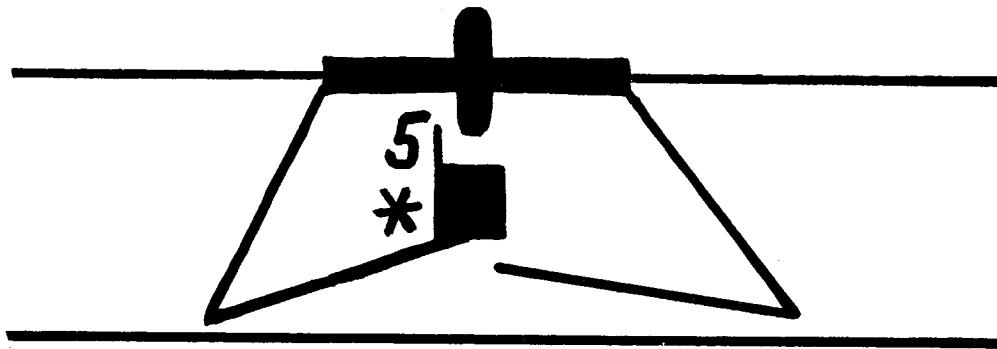
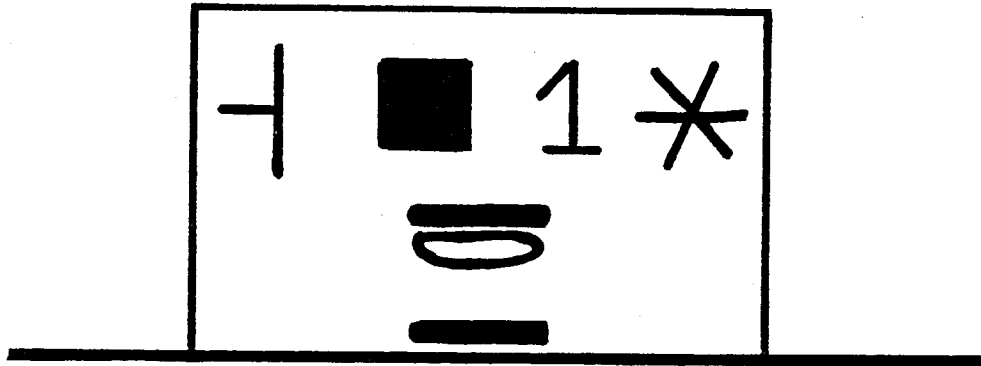

# SPECIAL INFORMATION BOXES

## CONTACT STARS

- 1. Touching: \*
- 2. Holding: +
- 3. Striking: #
- 4. Brushing: ⊙
- 5. Rubbing: ⊙
- 6. Pushing: ~
- 7. Pulling: ~
- 8. Pinching: #+
- 9. Pounding: #~
- 10. Snapping: #⊙

11. Slide: ⊙

13. Linked: +|\*|

12. Glide: ⊙

14. Grabbing: #+

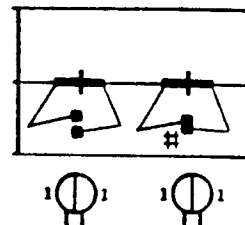
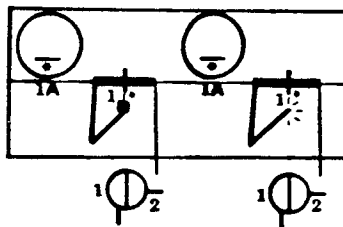

## SPECIAL INFORMATION BOXES

Heel Of Hand: ⊙

Tip of Hand: ⊙

- Right Side: |
- Left Side: |
- Under: ⊖
- Over: ⊕
- Outside Right: d
- Outside Left: b
- Inside Right: b
- Inside Left: d
- In Front Of: ⊙
- In Back Of: ⊙
- To The Side Of: ⊙
- Tension: ⊗
- Relaxation: ⊗
- Blow Air: >
- Male: ▽
- Female: ▽
- From: ÷
- Neck: ⊕
- Shoulders: ⊕
- Upper Arm: ⊕

- Elbow: ⊕
- Lower Arm: ⊕
- Wrist: ⊕
- Hand: ⊕
- Relaxed Hand: ⊕
- Other Hand Shapes: Same As Always
- Fingers: ⊕
- Specific Fingers: 1, 2, 3, 4, 5
- Joints of Fingers: A, B, C, D, E, F, G
- Upper Torso: ⊕
- Middle Torso: ⊕
- Lower Torso: ⊕
- The Heart: ⊕
- The Naval: ⊕
- The Ribs: ⊕
- Concave Stomach: ⊕
- Bloating Stomach: ⊕
- Hips: ⊕
- Thigh: ⊕
- Inside Or Between: |\*|

Fingernails: ⊕

Palm of The Hand: ⊕

Top of The Hand: ⊕

Contact Stars: Same As Always

Facial Expressions: Same As Always

Whole Arm: ⊕

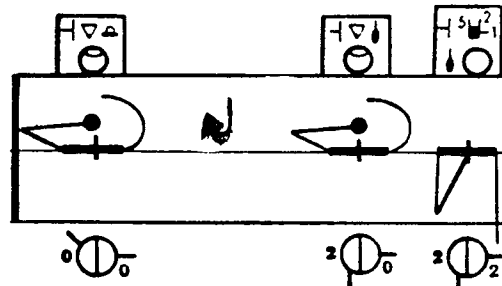
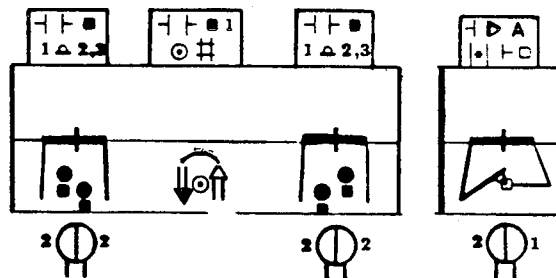

# REPEAT SIGNS

## MEASURE REPEATS



## MEASURE REPEATS

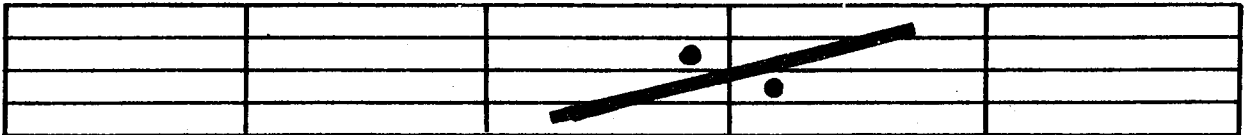

## MEASURE REPEATS



## REGULAR REPEATS

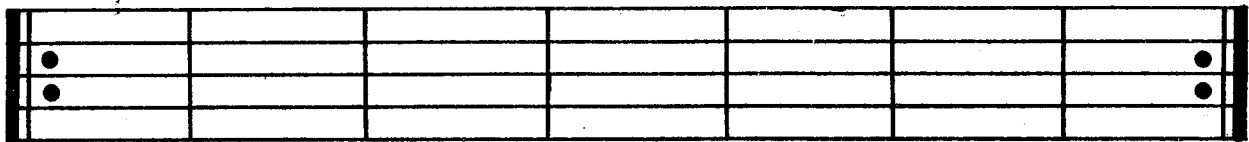

## REGULAR OPPOSITE



# BACK TO AUDIENCE

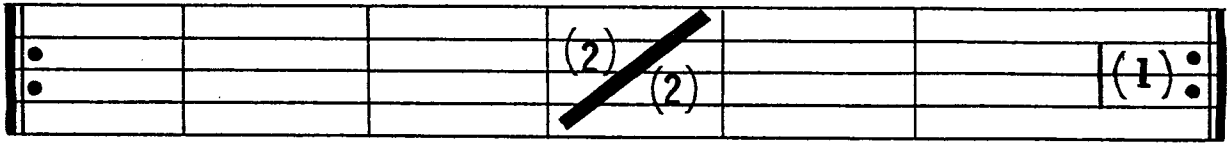

# REPEATS INSIDE A MEASURE

Repeat  
First Half  
Of Measure  
In Last Half



Repeat  
First Third  
Of Measure  
In The Middle

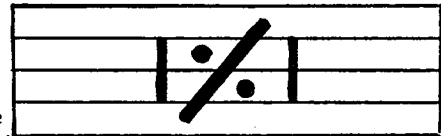

# FACING ANY OTHER WALL

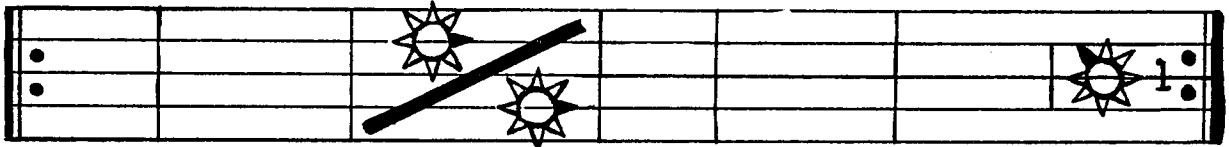

# *f* FROM THE SIGN TO THE END

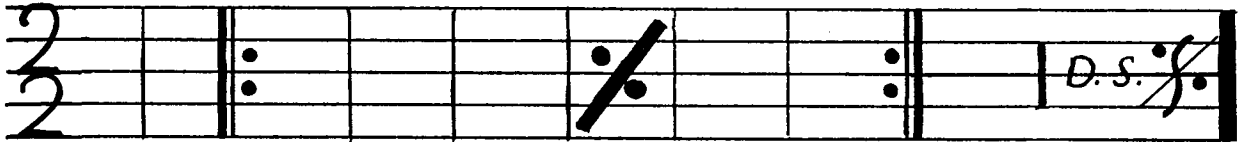

# *f* FROM THE SIGN TO THE SIGN



Repeated As  
Many Times  
As Performer  
Wishes:

*Ad Libitum*

Copyright © 1978 By Valerie J. Sutton  
ALL RIGHTS RESERVED  
Pan American And Universal Copyrights Secured

Repeated An  
Infinite  
Number of Times:

$\infty$

# FROM THE BEGINNING TO FINÉ

A musical staff with a treble clef. It begins with a double bar line and a repeat sign. The staff contains several empty measures. It ends with a double bar line, a repeat sign, and the word "Finé" written above the staff. Below the staff, the text "D.C. al Finé" is written.

## THE ETC. ETC. REPEAT

A musical staff with a treble clef. Above the staff, the numbers 1, 2, 1, 2, 1, 2, 1, 2 are placed above the measures. The staff contains several empty measures. It features a large left-pointing arrow on the left and a large right-pointing arrow on the right. In the center, there is a repeat sign with "x7" written next to it.

## FROM THE SIGN OPPOSITE, REVERSE, MANY TIMES

Three boxes, each containing a musical staff with a different "D.S." marking. The first box shows "D.S." with a slash and an "x" below it. The second box shows "D.S." with a slash and a "V" above and a "v" below it. The third box shows "D.S." with a slash and an "8" below it.

## TO FINÉ OPPOSITE, REVERSE, MANY TIMES

Three boxes, each containing a musical staff with a different "D.C. al Finé" marking. The first box shows "D.C. al Finé" followed by an "X". The second box shows "D.C. al Finé" followed by a "V" above and a "v" below. The third box shows "D.C. al Finé" followed by the number "12".

## REPEATS WITH SPECIAL INFORMATION BOXES

A musical staff with a treble clef. It is divided into several sections. The first section has a box above it containing a sun-like symbol with eight rays and the number "2". The second section has a box above it containing seven numbered symbols (1-7) representing different directions. The third section has a box above it containing a circle with a vertical line and the number "2". The fourth section has a box above it containing a circle with a vertical line and the number "1". The staff itself contains a diagonal line with a dot above it, a diagonal line with a "7" below it, and a repeat sign with "x1" written next to it.



# DIFFERENT BEGINNINGS

A musical staff with five lines. Above the staff, there are four boxes labeled '1.' and '2.'. The first box '1.' contains a vertical bar line. The second box '2.' contains two dots on the first and second lines. The third box '1.' is empty. The fourth box '2.' is empty. The fifth box contains a triplet of notes with a diagonal slash and the number '3' above and below it. The sixth box contains a repeat sign with 'X1' and two dots. The seventh box '2.' is empty.

# DIFFERENT MIDDLES

A musical staff with five lines. Above the staff, there are four boxes labeled '1.' and '2.'. The first box '1.' is empty. The second box '2.' contains a double bar line. The third box '2.' contains a double bar line and a diagonal slash with a dot above and below it. The fourth box '1.' is empty. The fifth box '2.' is empty. The sixth box '1.' is empty. The seventh box '2.' is empty. The eighth box contains a repeat sign with 'X1' and two dots. The ninth box '2.' is empty.

# DIFFERENT ENDINGS

A musical staff with five lines. Above the staff, there are four boxes labeled '1.' and '2.'. The first box '1.' is empty. The second box '2.' is empty. The third box '1.' is empty. The fourth box '2.' is empty. The fifth box contains a quintuplet of notes with a diagonal slash and the number '5' above and below it. The sixth box '1.' is empty. The seventh box '2.' is empty. The eighth box contains a repeat sign with 'X1' and two dots. The ninth box '2.' is empty.

# BEGINNINGS, MIDDLES, ENDINGS TOGETHER

A musical staff with five lines. Above the staff, there are four boxes labeled '1.' and '2.'. The first box '1.' contains a vertical bar line. The second box '2.' contains two dots on the first and second lines. The third box '1.' is empty. The fourth box '2.' is empty. The fifth box '1.' is empty. The sixth box '2.' is empty. The seventh box '1.' is empty. The eighth box '2.' contains a double bar line and a diagonal slash with two dots above and below it. The ninth box contains a repeat sign with 'X1' and two dots. The tenth box '2.' is empty.

# ONE ENDING USED BY TWO DIFFERENT REPEATS

A musical staff with five lines. Above the staff, there are four boxes labeled '1.' and '2.'. The first box '1.' is empty. The second box '2.' is empty. The third box '1.' is empty. The fourth box '2.' is empty. The fifth box '1.' is empty. The sixth box '2.' is empty. The seventh box '1.' is empty. The eighth box '2.' contains a double bar line and a diagonal slash with the number '2' above and below it. The ninth box '1.' is empty. The tenth box '2.' is empty. The eleventh box contains a repeat sign with 'X1' and two dots. The twelfth box '2.' is empty.

SILENT COUNTS

When a rest occurs in music in both the treble and base clefs there is silence. For those who dance without reading or knowing the music, these silent counts can be confusing. They should not be skipped over even though they are not heard. A dotted-lined circle is written around counts placed above the Movement Staff that are silent. When reading the notation, the reader knows that the encircled count is in the music but is not heard. Counts without anything around them are assumed to be music counts that are heard.

MOVER'S COUNTS

Movement is not always coordinated to music. It can be executed in silence, coordinated with an inner rhythm inside the mover. The mover may move to music and not follow the music at all, but move to an inner rhythm. The mover can also move to music and follow the music's counts exactly; then suddenly the music stops and the mover continues to move on his own, to his own rhythm. All of these employ the notation of Mover's Counts in Sutton Dance Writing.

Mover's Counts are notated by writing a dotted-lined triangle around the counts placed above the Staff that are Mover's Counts. Triangles always represent the "mover" in Sutton Dance Writing.

MEMOS

When the notator wishes to tell the reader something extra about the notation having to do with costumes, lighting, decor or any other message other than the movement itself, a number is placed above the staff encased in an oval. This is the Memo Sign. The reader refers to the end of the manuscript, finds the number of the memo, and reads the message. It is a footnote to the reader:

NUMBERING OF MEASURES

For lengthy manuscripts the notator may want to number each measure for easy reference. The number of the measure is placed above the staff, directly over the first measure line of the measure (it precedes the measure). The number is encased inside a box or square:

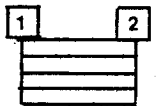
IN SUMMARY

Music Counts that are heard: Number placed above staff without anything around it.  
 Music Counts that are silent: Number placed above the staff with a dotted circle.  
 Mover's Counts (rythm without music): Number above staff with dotted triangle.  
 Memos: Number placed above the staff encased in an oval.  
 Numbering of Measures: Number placed above the staff encased in a square.

Copyright © 1977 by Valerie J. Sutton

All Rights Reserved

Pan American and Universal Copyright Secured

**MODERN**

**AND**

**JAZZ DANCE**

**READING LESSONS**

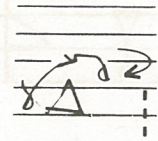

SUTTON DANCE WRITING™  
MODERN & JAZZ DANCE WRITING  
Reading Lesson One

Ⓡ

Ⓢ

SUTTON DANCE WRITING™  
MODERN & JAZZ DANCE WRITING  
Reading Lesson Two

**I**

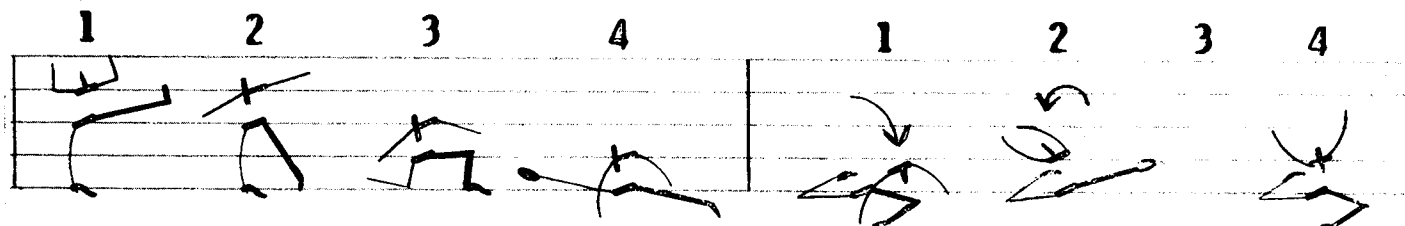
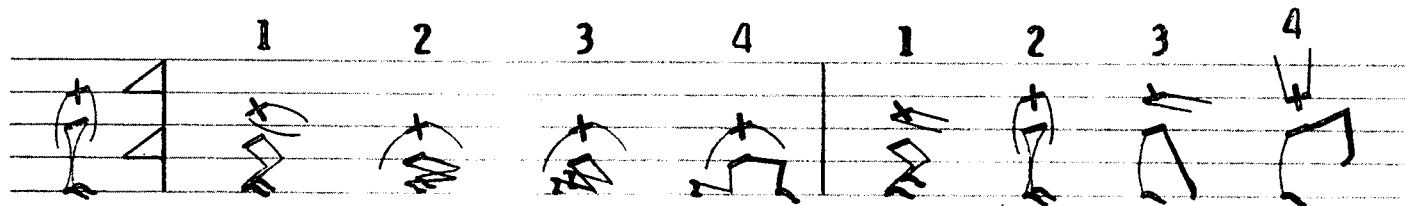

**II**

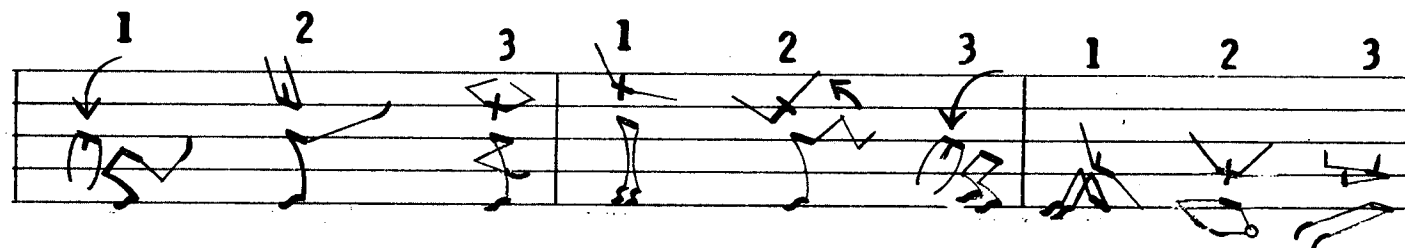
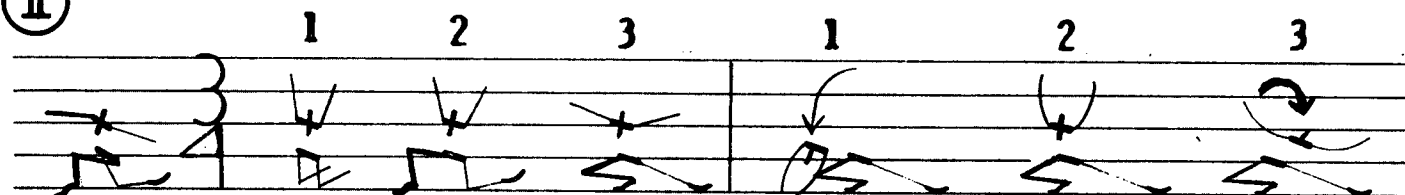

SUTTON DANCE WRITING™  
MODERN & JAZZ DANCE WRITING  
Reading Lesson Three

I

The first exercise, labeled 'I', is written on two staves of music. The first staff contains six measures of notation, with steps numbered 1, 2, 3, 4, 1, and 2 above them. The second staff contains six measures, with steps numbered 3, 4, 1, 2, 3, and 4 above them. Each measure shows a sequence of foot positions and movement directions indicated by arrows and dots.

II

The second exercise, labeled 'II', is written on two staves of music. The first staff contains seven measures, with steps numbered 1, 2, 1, 2, 1, and 2 above them. The second staff contains seven measures, with steps numbered 1, 2, 1, 2, 1, 2, and 4 above them. The notation includes foot positions, movement arrows, and dots to indicate timing and direction.

SUTTON DANCE WRITING™  
MODERN & JAZZ DANCE WRITING  
Reading Lesson Four

I

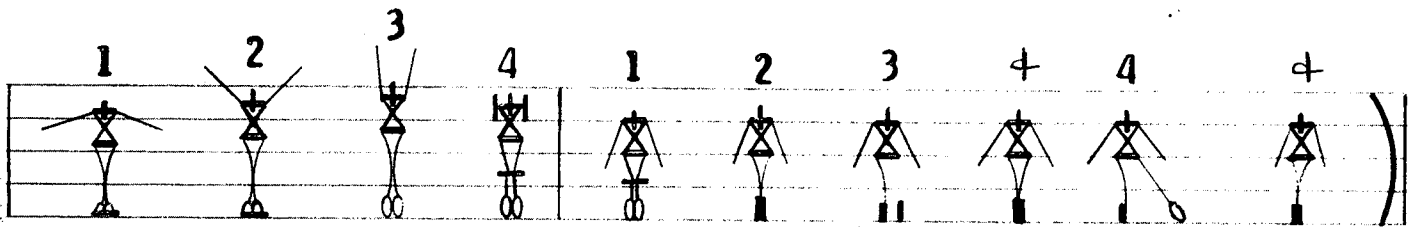
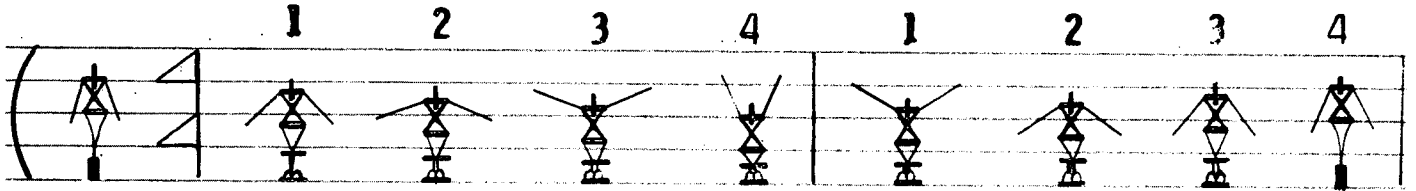

II

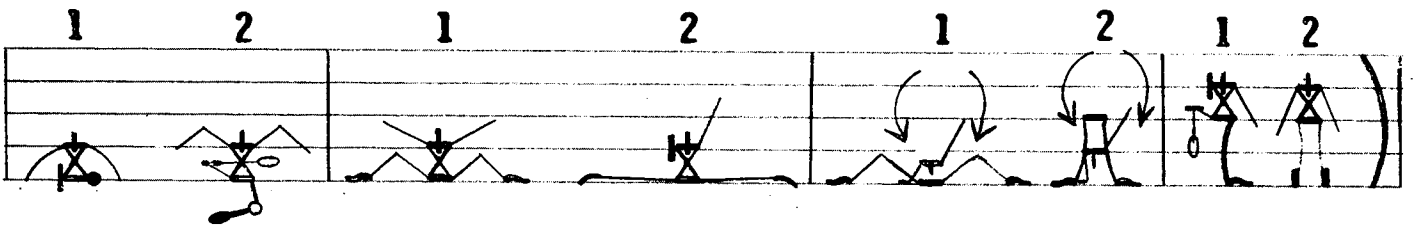
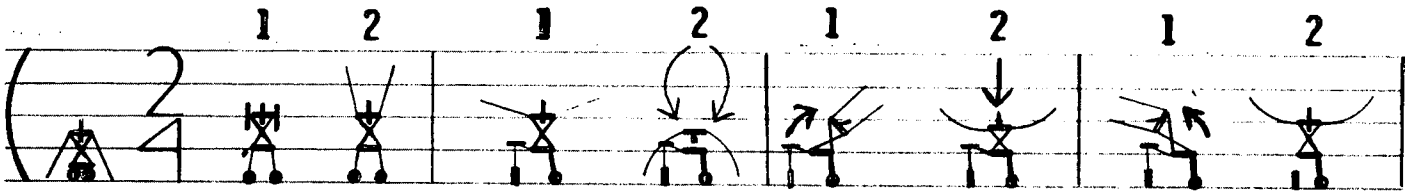

SUTTON DANCE WRITING™  
MODERN & JAZZ DANCE WRITING  
Reading Lesson Five

**I**

**II**



III

Section III consists of two staves of musical notation. The first staff is in treble clef with a key signature of one sharp (F#). It contains four measures of music, each with a measure number (1, 2, 1, 2) above it. The second staff is in bass clef with a key signature of one sharp (F#). It contains ten measures of music, each with a measure number (1, 2, 1, 2, 1, 2, 1, 2, 1, 2) above it. Fingerings are indicated by numbers 1, 2, 3, and 0. Some notes are circled with numbers, and some are crossed out with a diagonal line. There are also some diagrams showing finger positions on a string.

IV

Section IV consists of two staves of musical notation. The first staff is in treble clef with a key signature of one sharp (F#). It contains six measures of music, each with a measure number (1, 2, 3, 4, 1, 2) above it. The second staff is in bass clef with a key signature of one sharp (F#). It contains six measures of music, each with a measure number (3, 4, 1, 2, 3, 4) above it. Fingerings are indicated by numbers 1, 2, 3, 4, and 0. Some notes are circled with numbers, and some are crossed out with a diagonal line. There are also some diagrams showing finger positions on a string.

SUTTON DANCE WRITING™  
MODERN & JAZZ DANCE WRITING  
Reading Lesson Six

1 2 3 4 1 2 3

Y

4 1

v

2 3 4

L

1 2 3 4

7

SUTTON DANCE WRITING™  
MODERN & JAZZ DANCE WRITING  
Reading Lesson Seven

The page contains three systems of dance notation, each consisting of a musical staff and a corresponding footwork diagram below it. The notation includes various symbols such as circles, triangles, and lines, often with numbers (1, 2, 3) indicating steps or counts. Some symbols are enclosed in boxes or have arrows pointing to them. The first system is numbered 1 through 5. The second system is numbered 6 through 8. The third system is numbered 1 through 8. The footwork diagrams use circles to represent feet, with numbers and arrows indicating the direction and timing of steps. Some diagrams include asterisks or other symbols to denote specific dance techniques or accents.

SUTTON DANCE WRITING™  
MODERN & JAZZ DANCE WRITING

Reading Lesson Eight

The image displays a complex musical score for dance, organized into eight numbered sections. Each section consists of a top staff with stick figures illustrating dance movements and a bottom staff with musical notation. The notation includes notes, rests, and time signatures such as 2/4, 3/4, and 4/4. Some sections are marked with '2 1/2' or '3 4' in parentheses, indicating specific rhythmic patterns. The stick figures are drawn in a simple, schematic style, showing the positions of the head, torso, and limbs. The overall layout is clean and professional, typical of a dance instruction manual.



Sutton Dance Writing™



# Quick - Writing

Booklet Two

Thirty-two Pages of Writing Exercises  
in Modern and Jazz Dance Notation

Drawings by Jayne Gunderson (Certified Instructor;  
S.M.W.) by Deborah Talbot and by Johan  
and Jennifer van Papendorp

Drawings on page 1, page 17 (top), and page 21 (top) by Deborah Talbot

Drawings on pages 2, 3, 12 (bottom), 17 (bottom), 20 (top), 21 (bottom),  
23, 24, 25, and 26 by Jayne Gunderson

All other drawings by Jennifer and Johan van Papendorp

**SUTTON DANCE WRITING  
QUICK-WRITING BOOKLET TWO**

Copyright © 1976 by Valerie J. Sutton  
All Rights Reserved  
Pan American and Universal Copyrights Secured









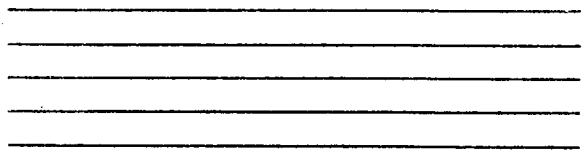
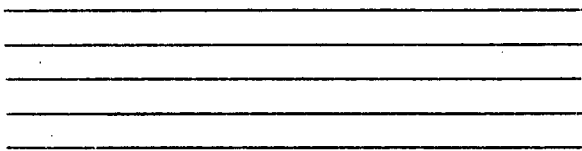
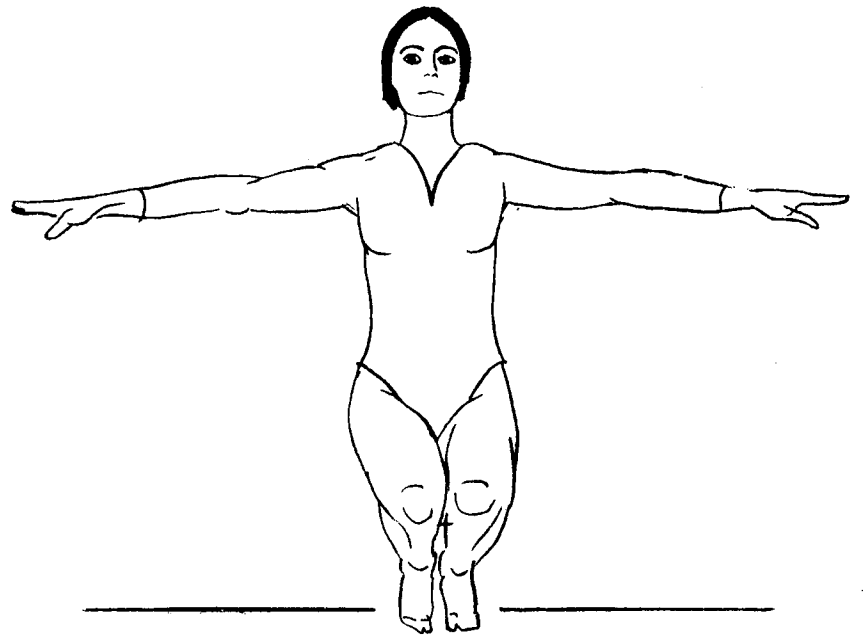
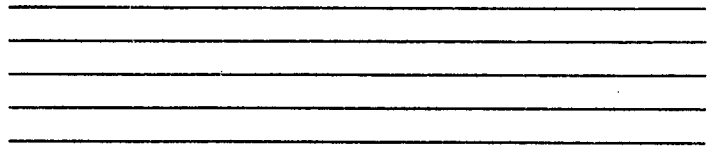
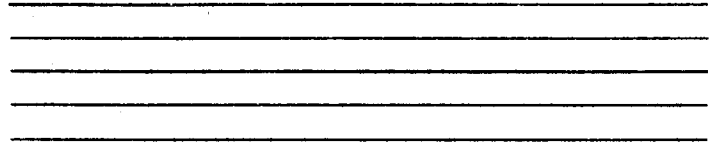
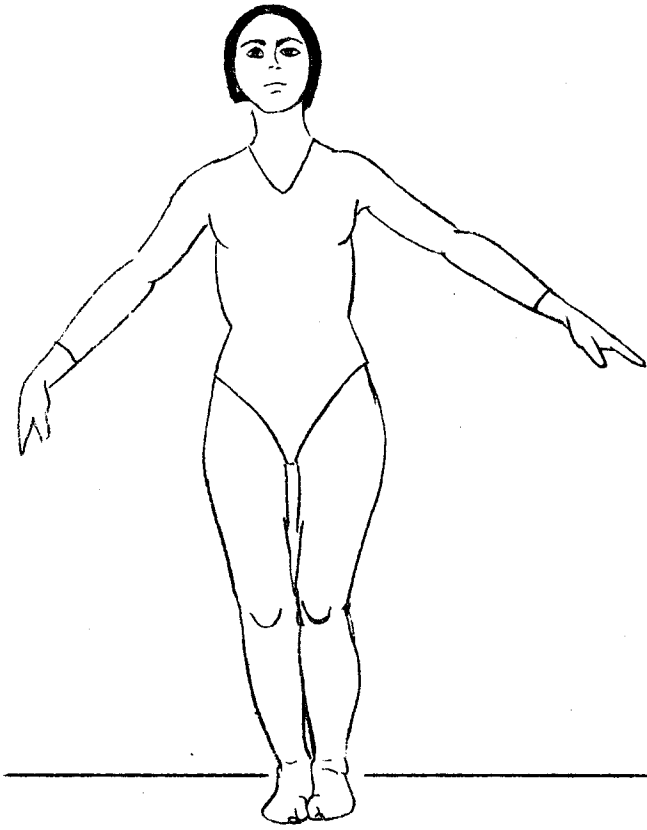

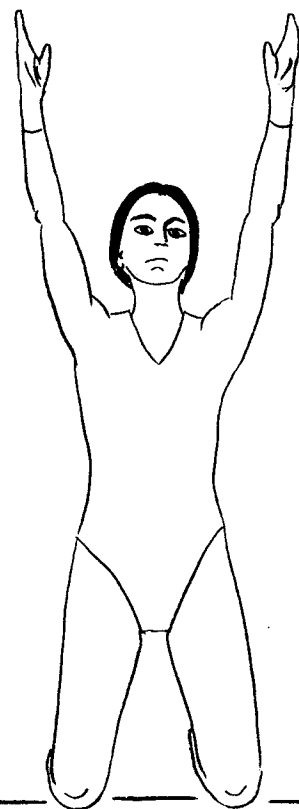
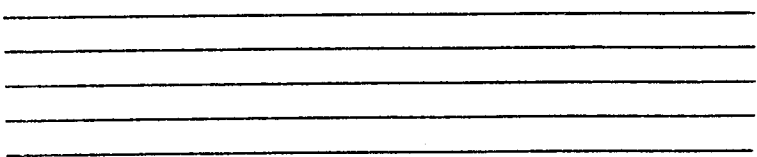
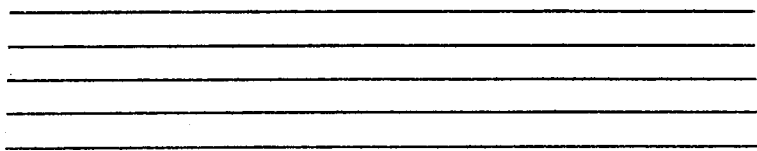
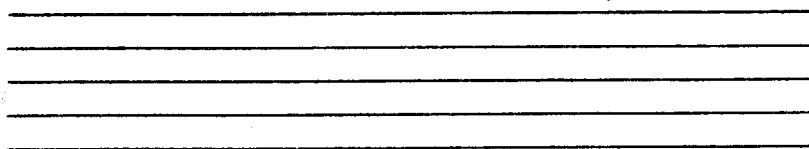
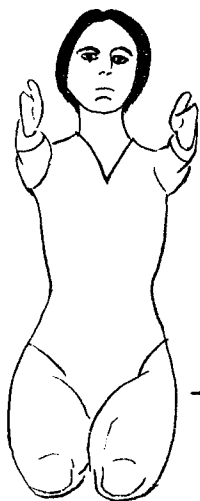

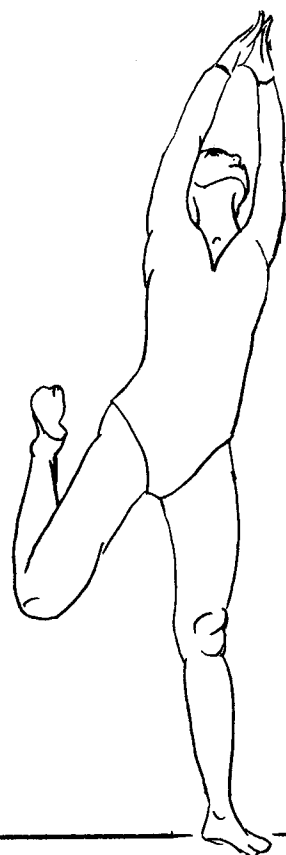
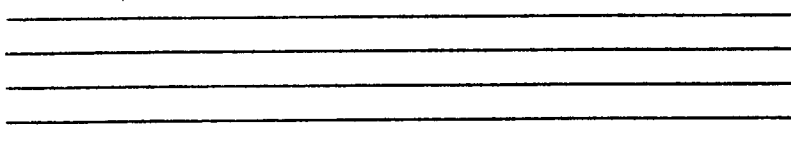
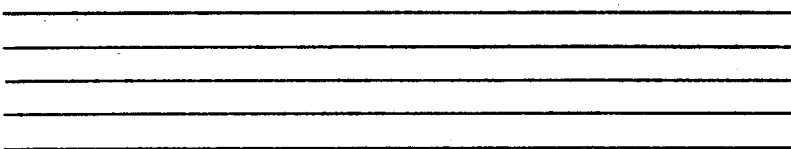
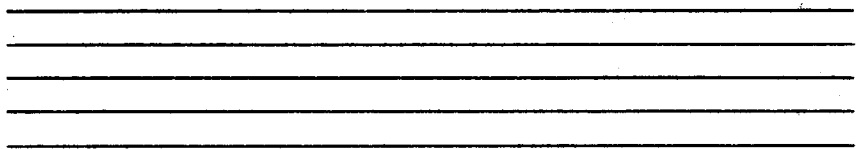
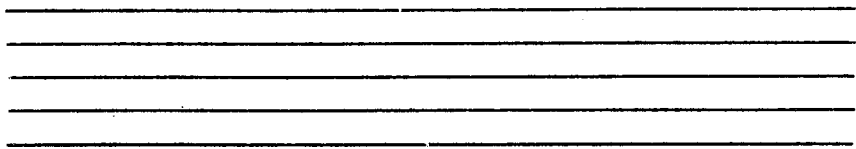
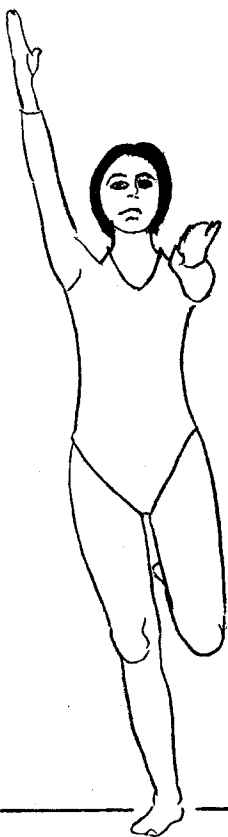

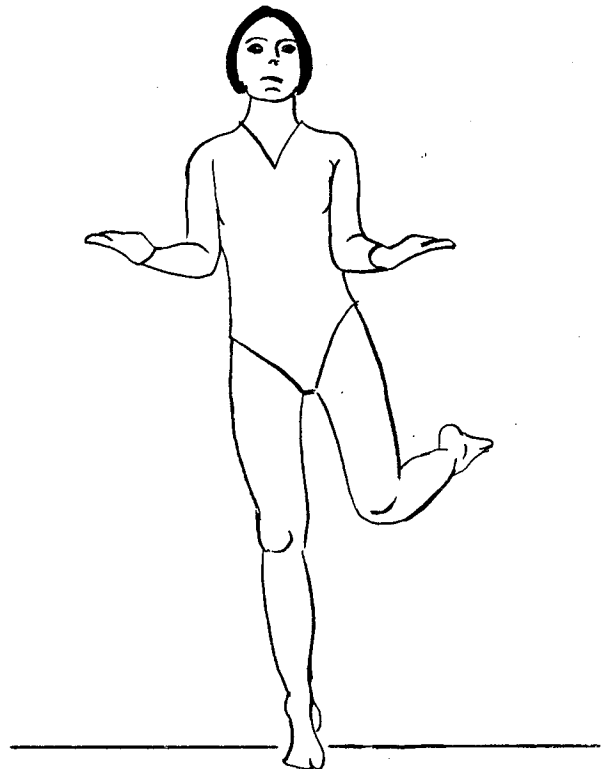
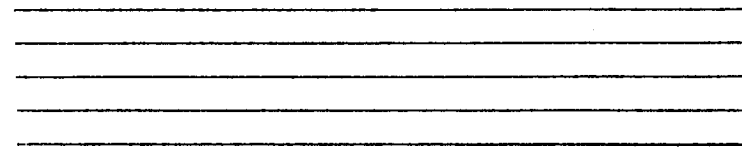
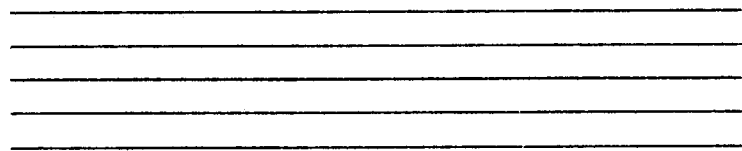
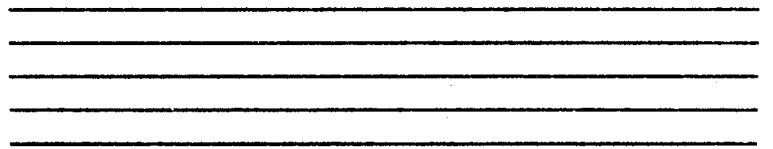
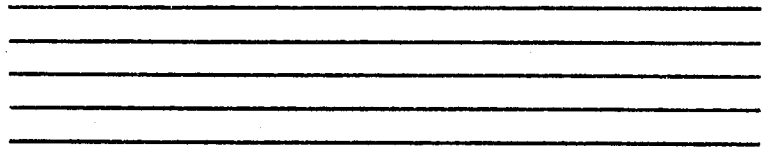
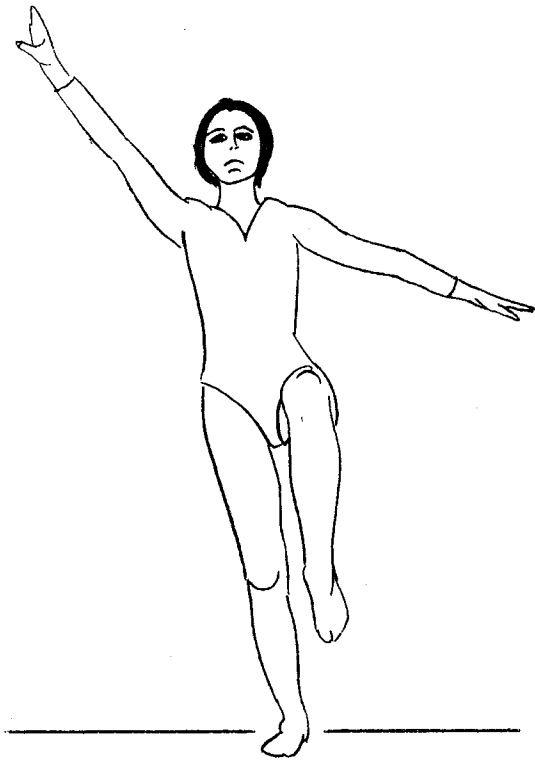

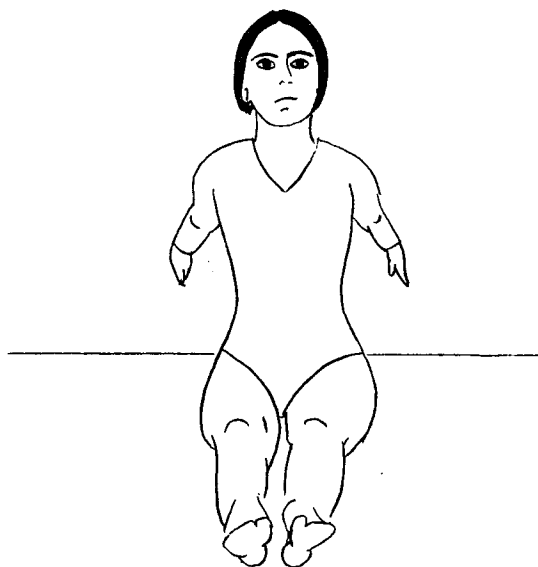
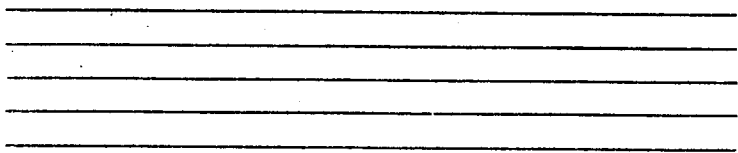
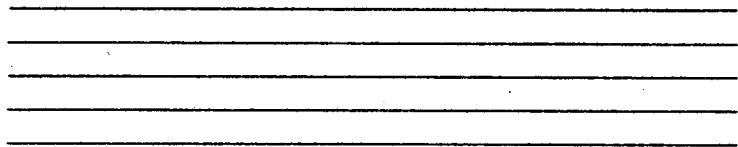
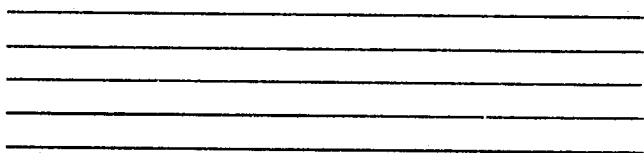
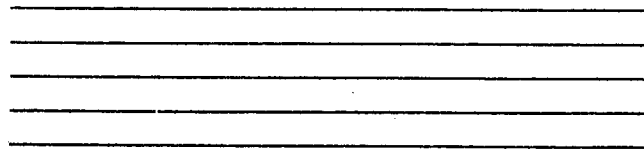
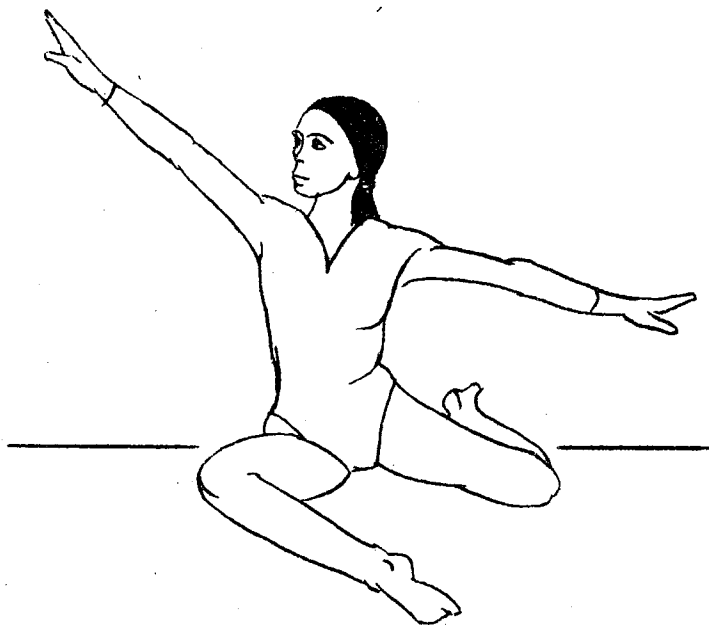

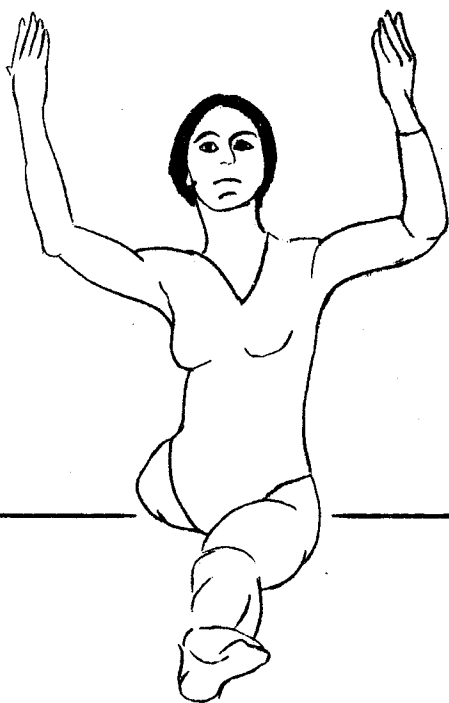

Four sets of horizontal lines for writing, each set consisting of four parallel lines.

Two sets of horizontal lines for writing, each set consisting of four parallel lines.

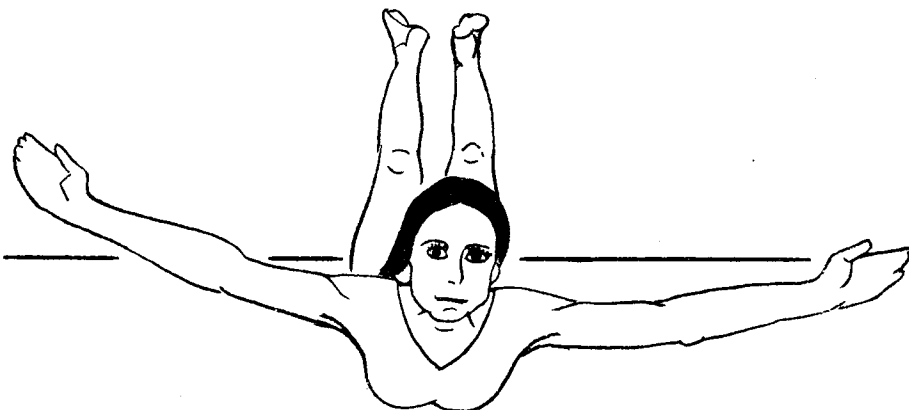

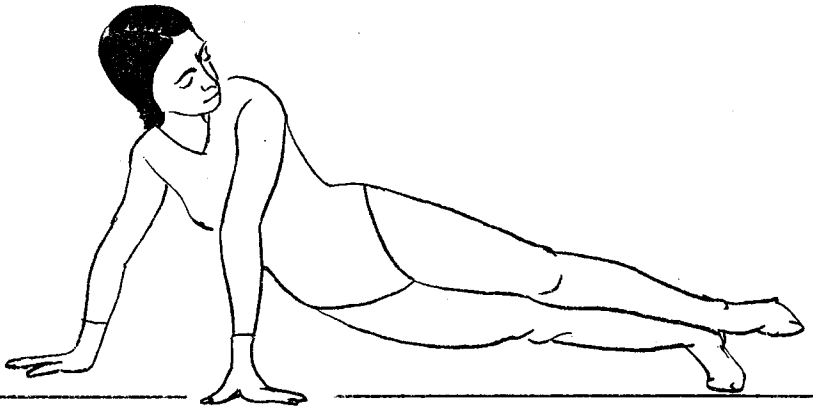

---

---

---

---

---

---

---

---

---

---

---

---

---

---

---

---

---

---

---

---

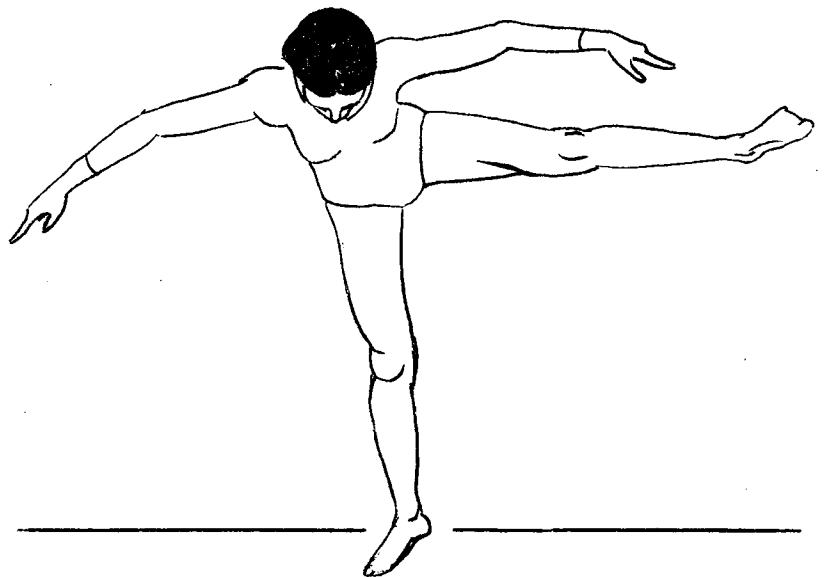

---

---



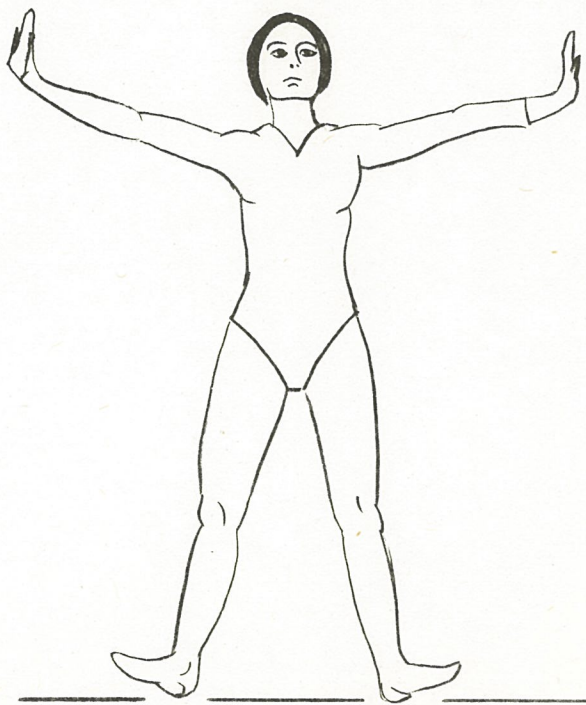
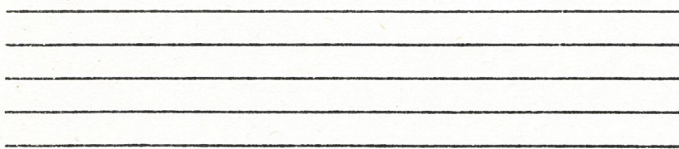
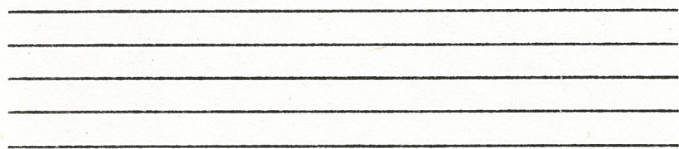
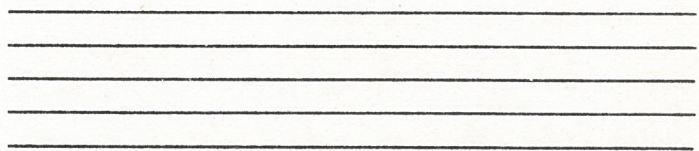
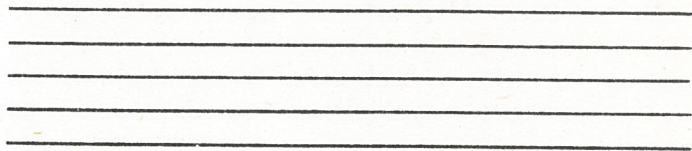

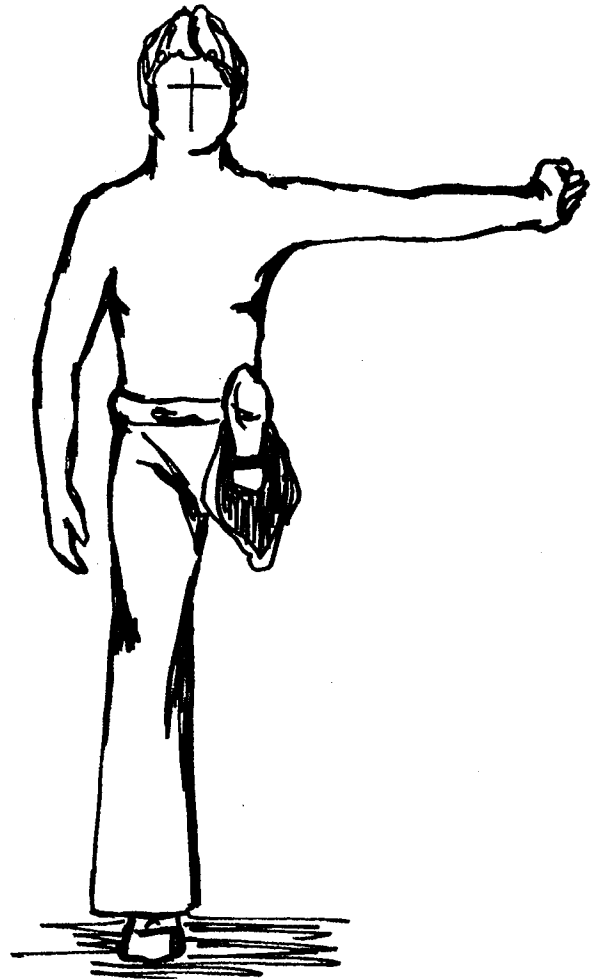
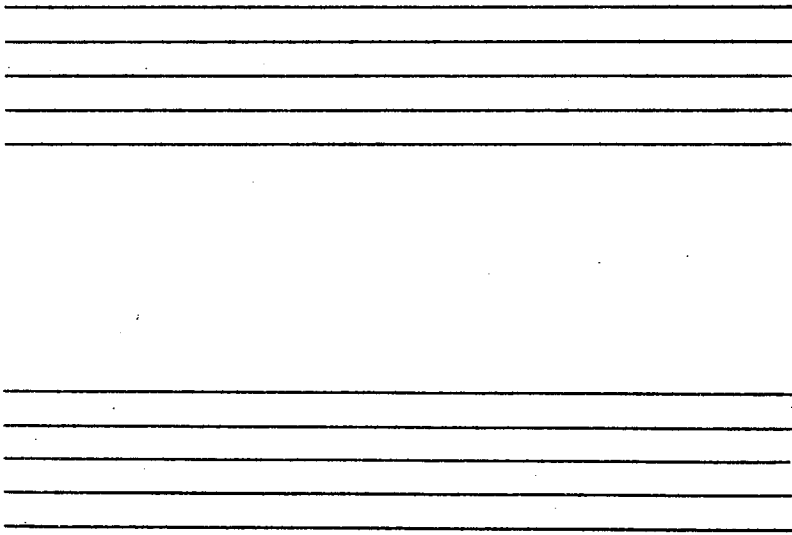
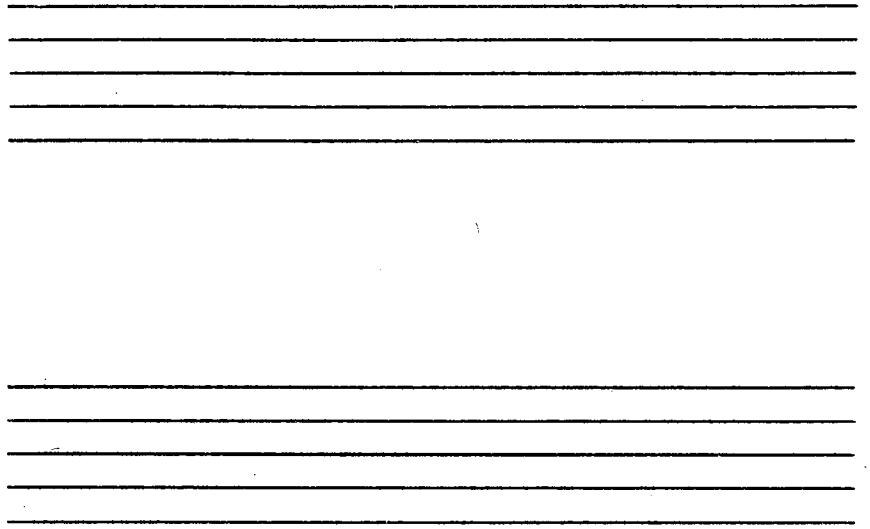
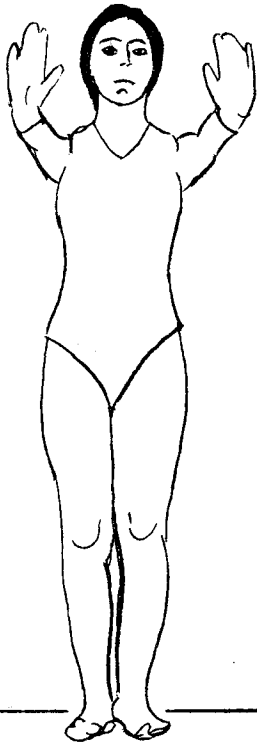

Copy each stick figure many times in a row for drawing practice:

I

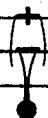

II



III

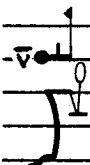

IV



V



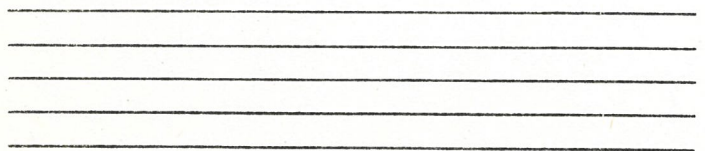
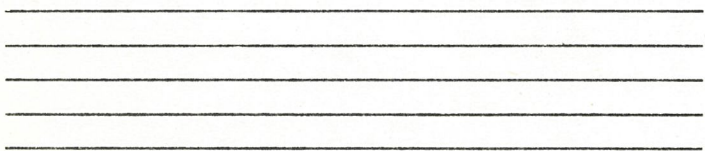
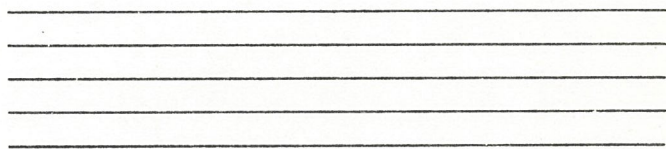
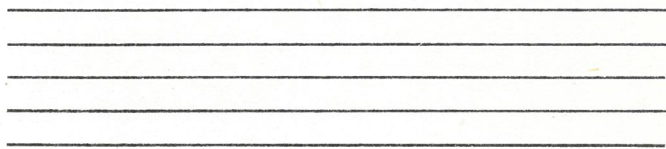

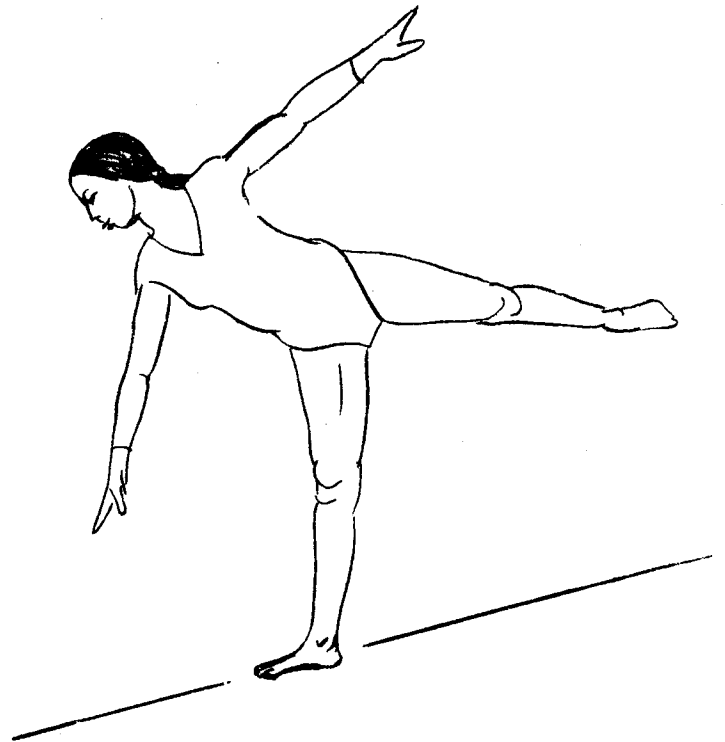
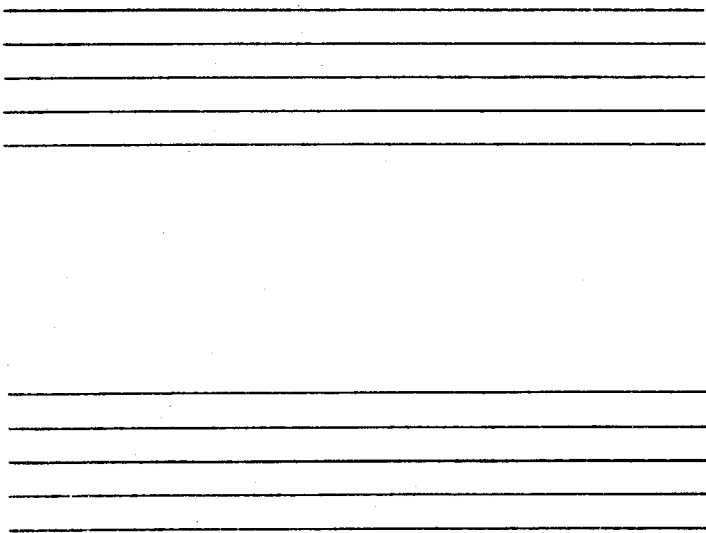
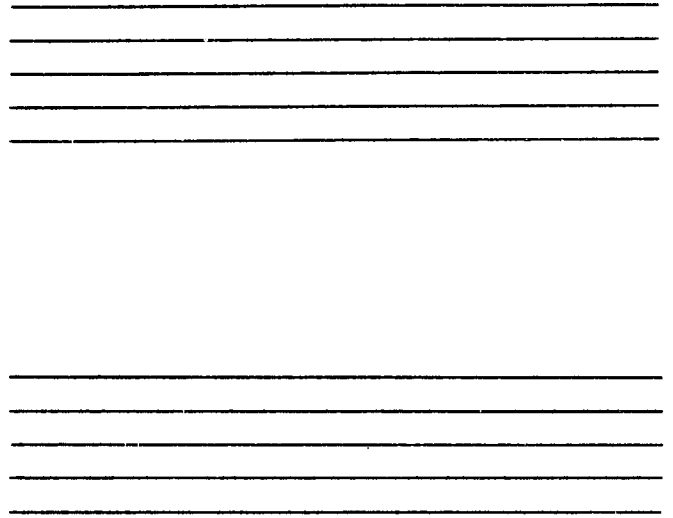
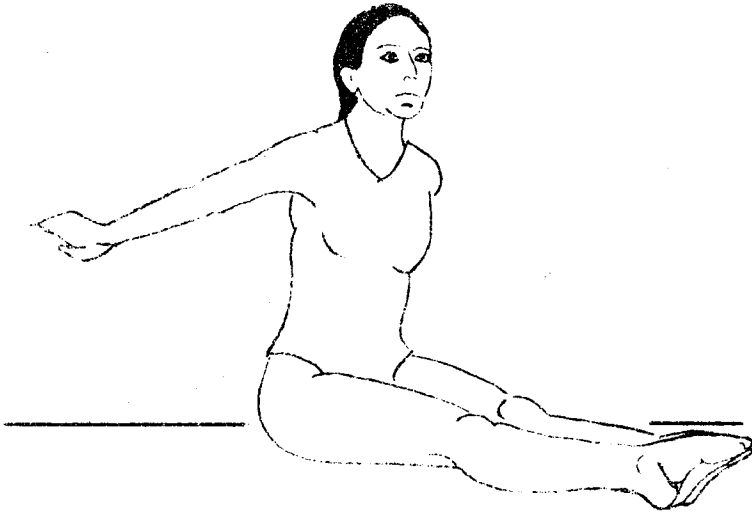



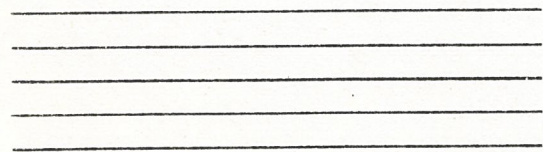
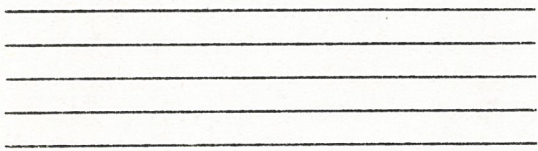
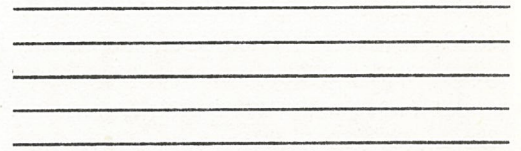
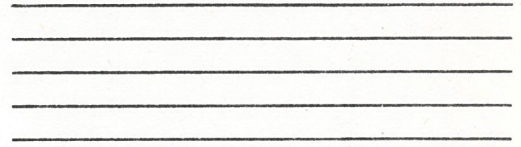

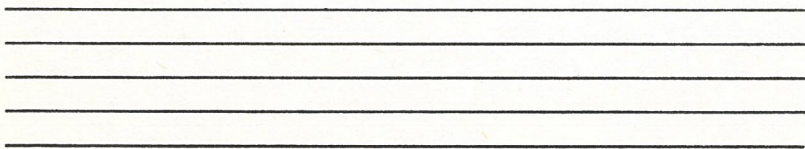
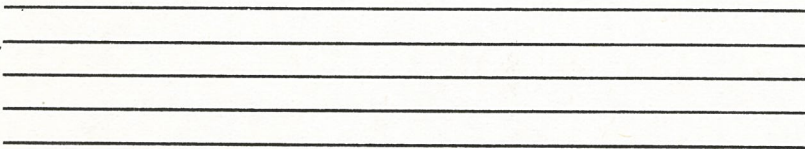
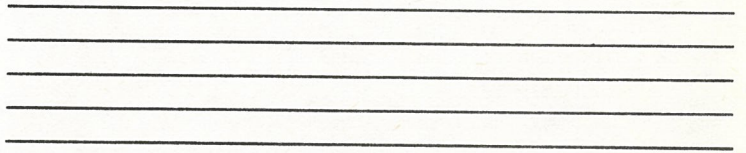
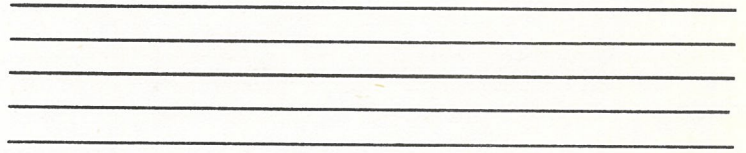

Copy each stick figure many times in a row for drawing practice:

I

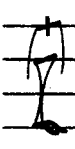

II



III

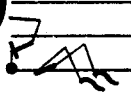

IV



V

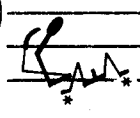



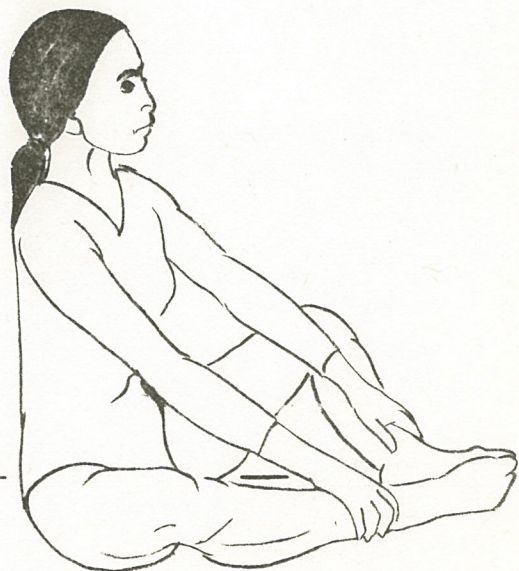
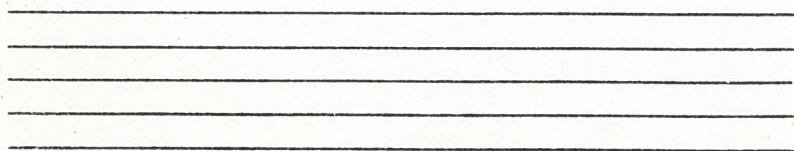
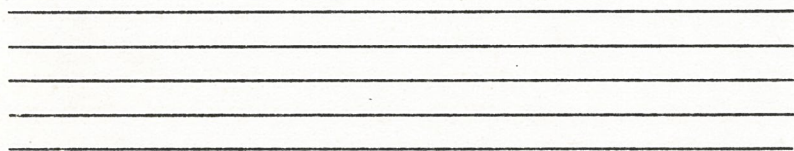
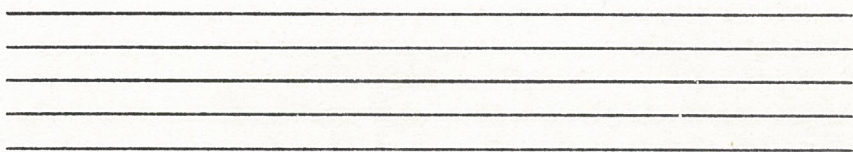
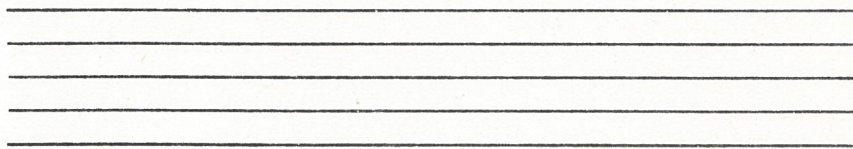

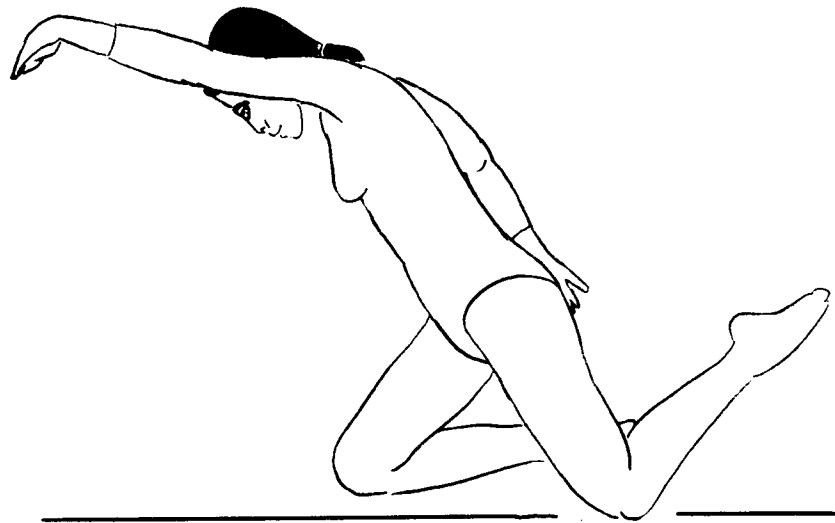
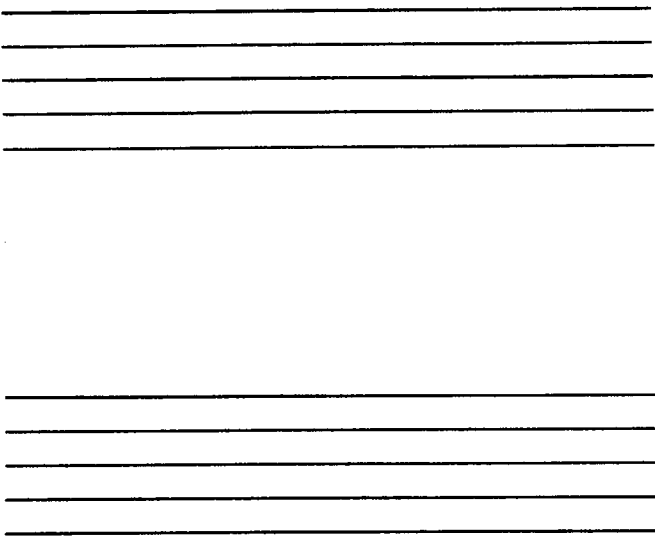
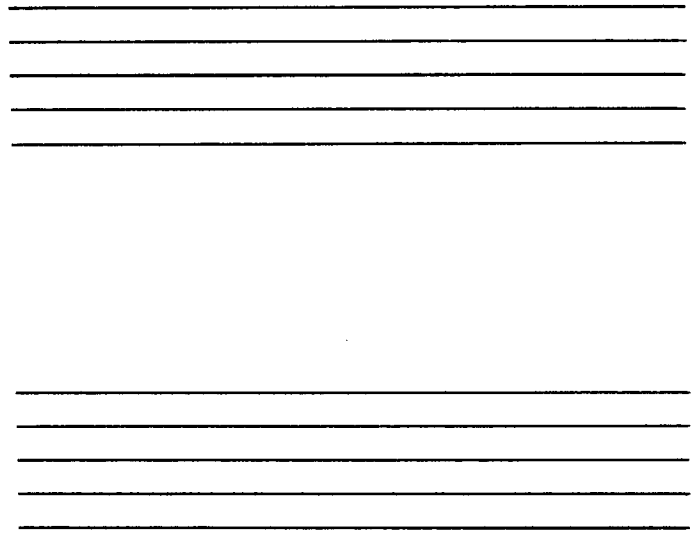

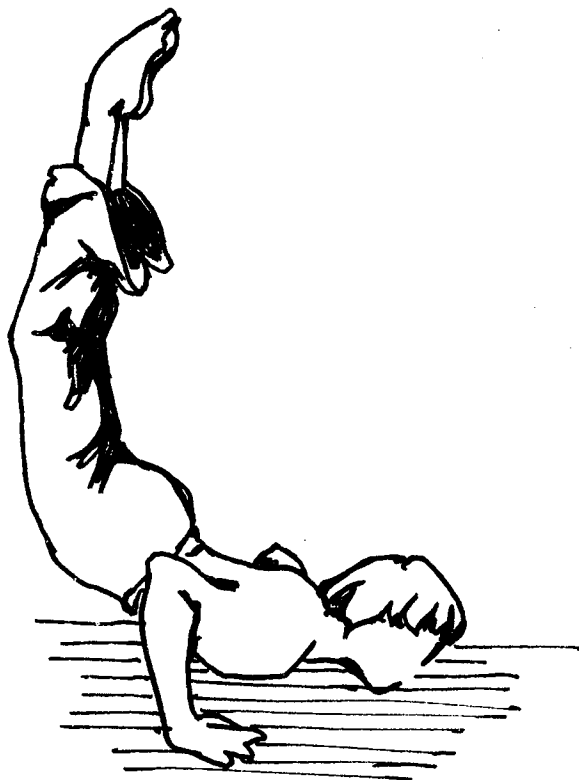
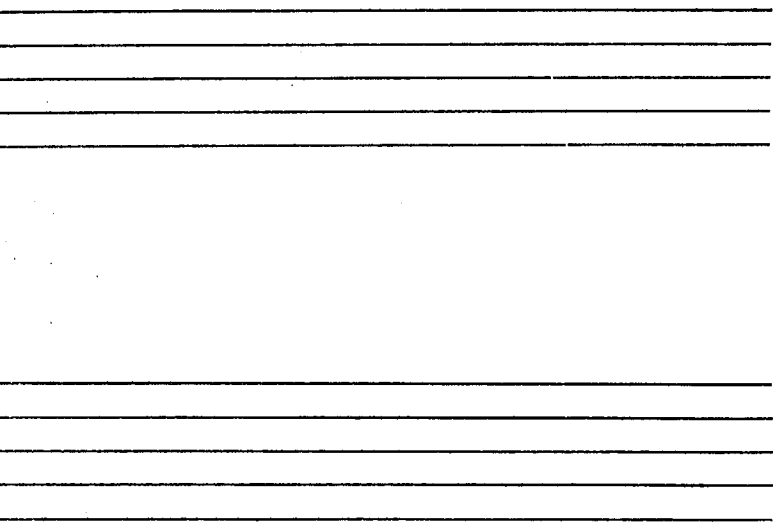
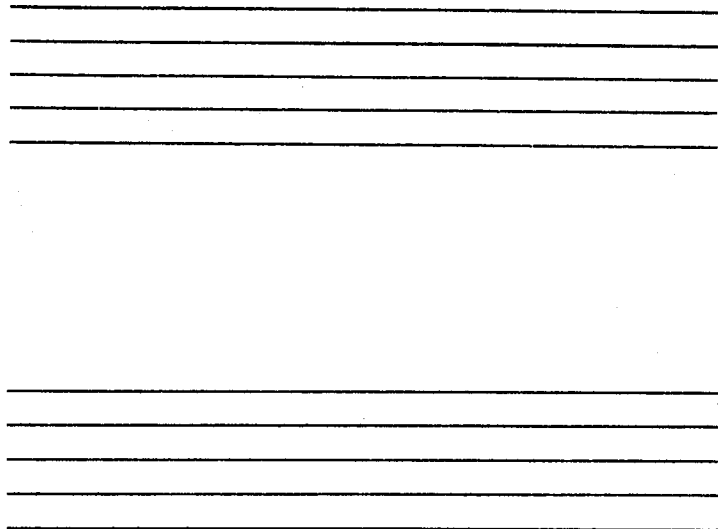
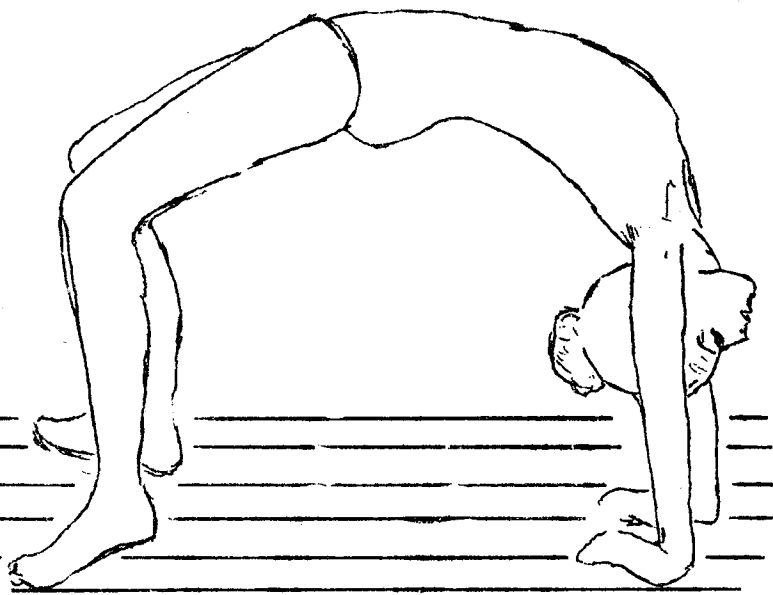

Copy each stick figure many times in a row for drawing practice:

I



II



III

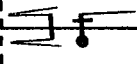

IV



V





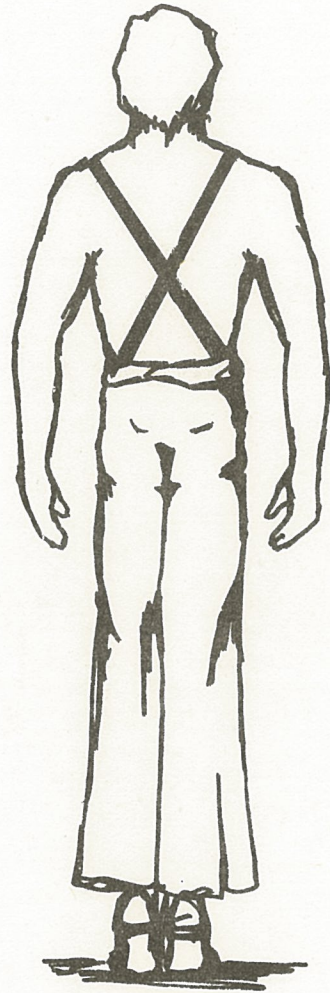
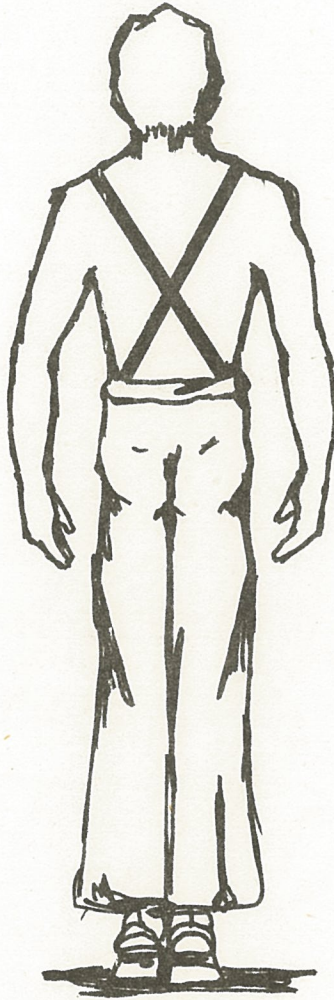
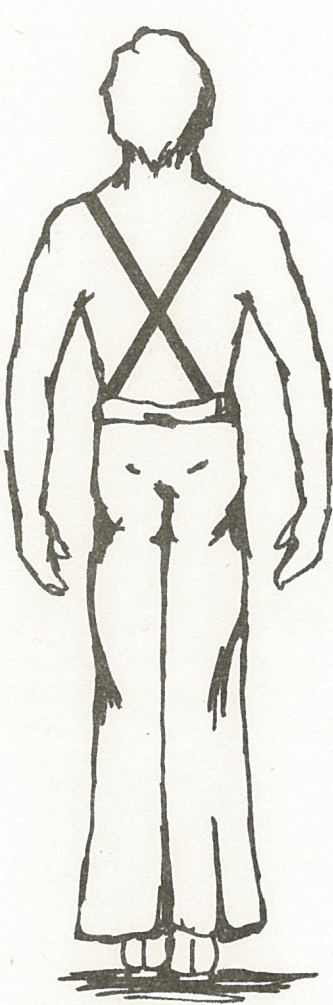

---

---

---

---

---

---

---

---

---

---



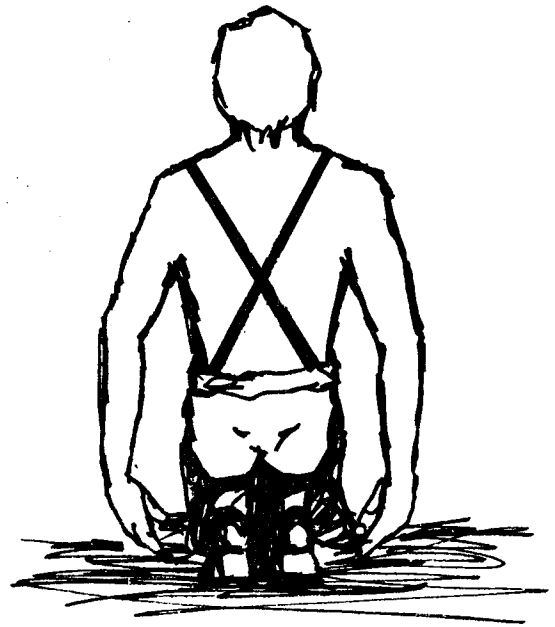
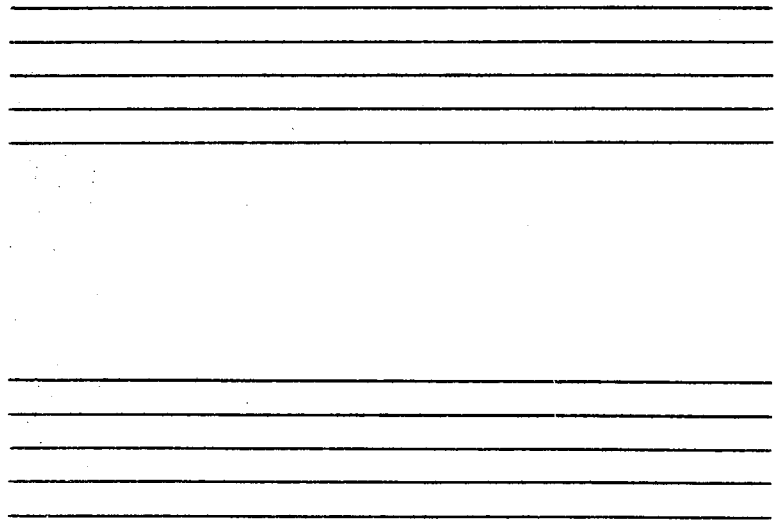
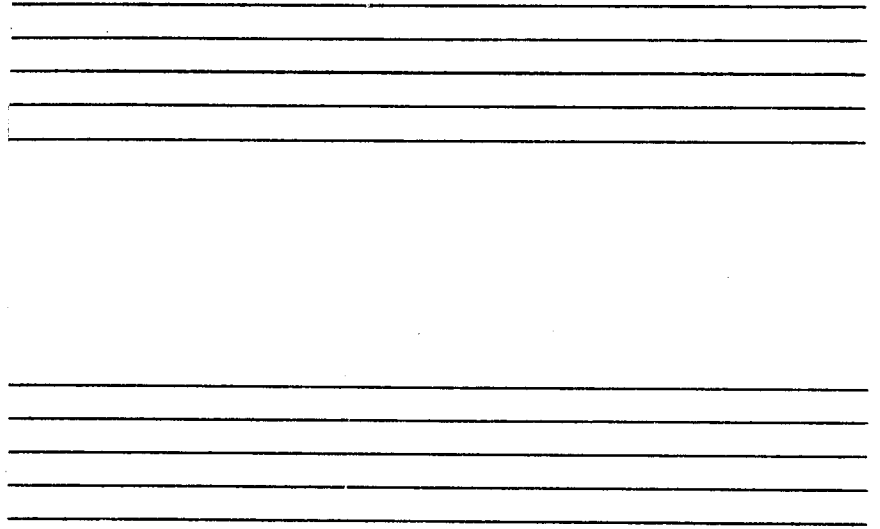
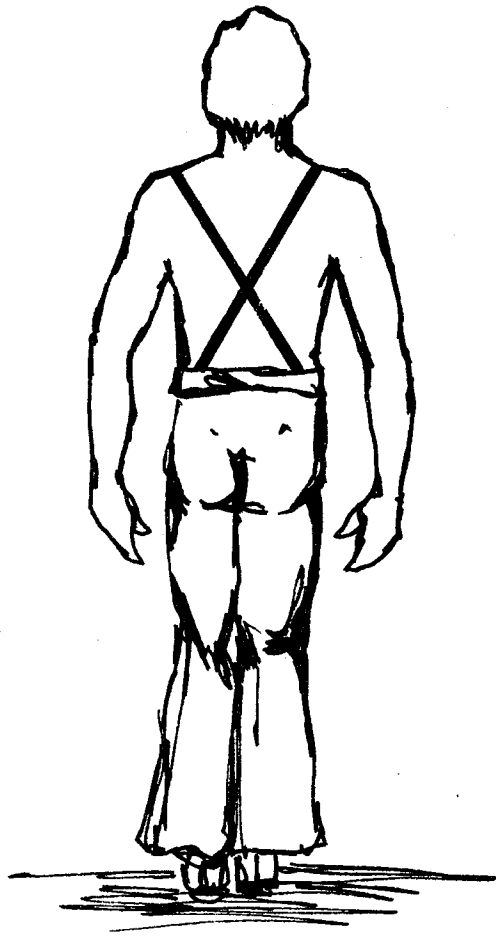



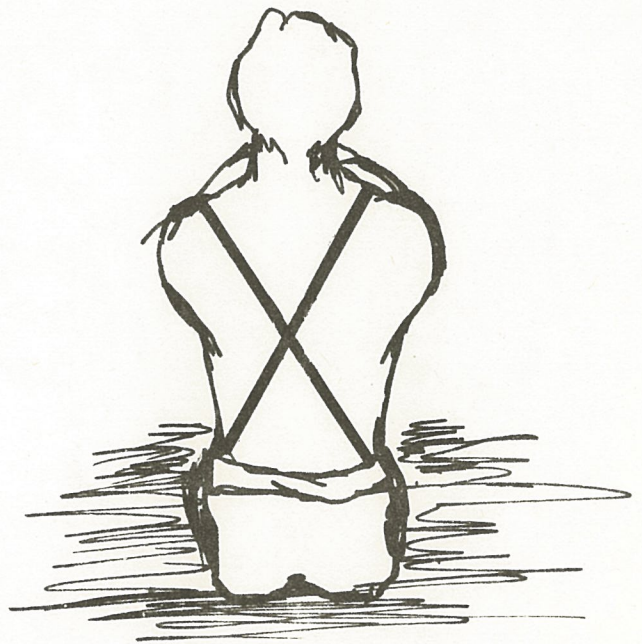
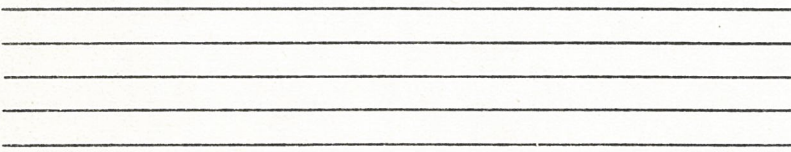
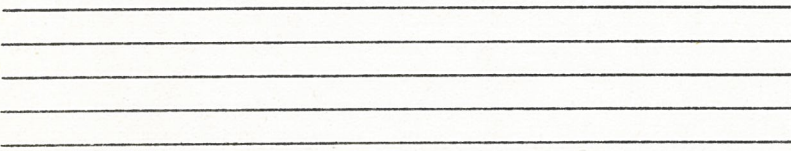
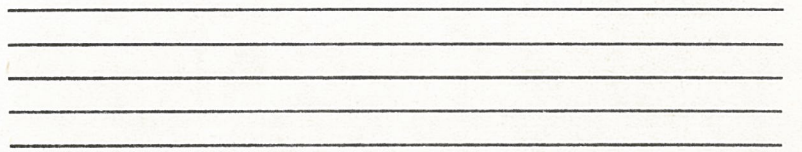
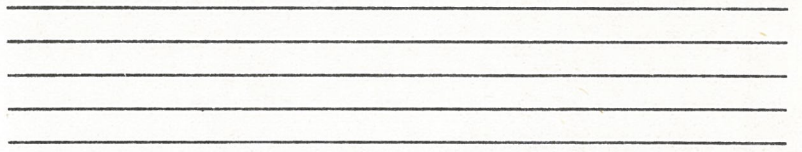
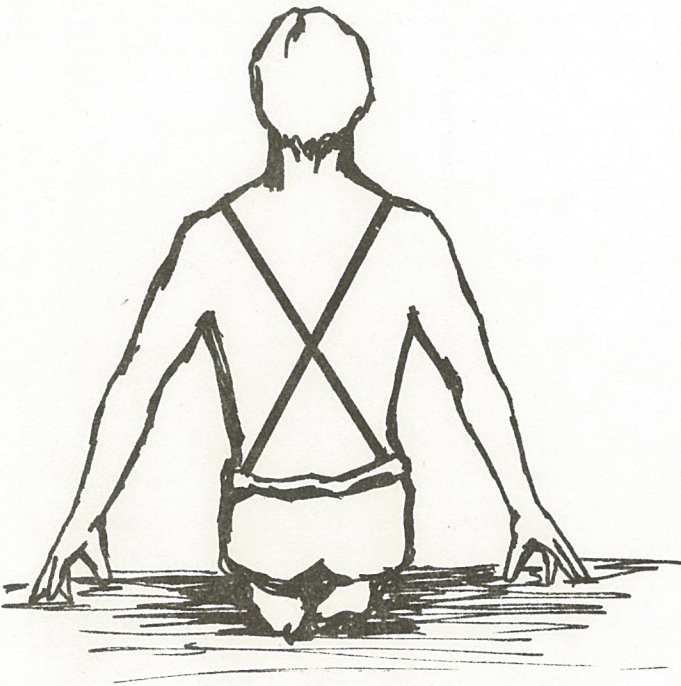



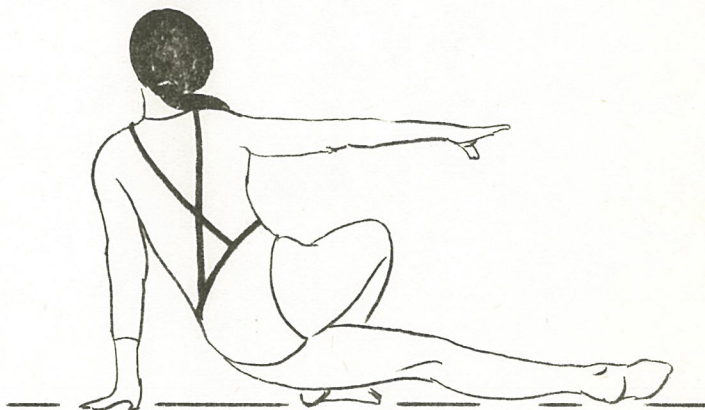
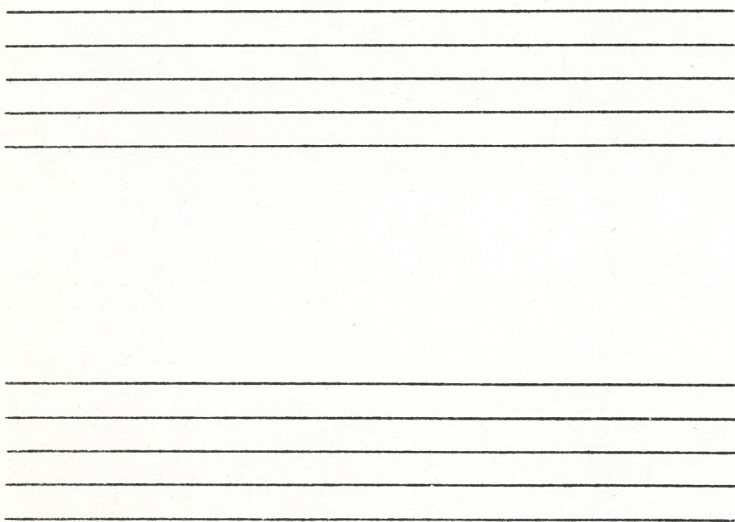
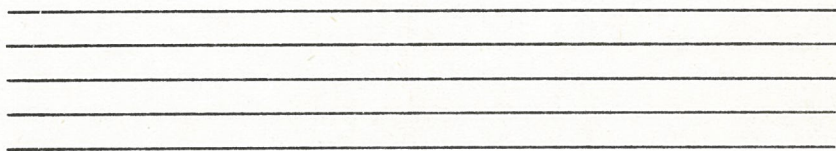
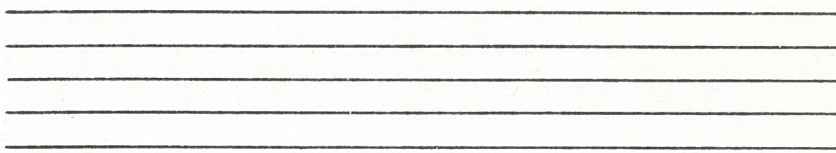

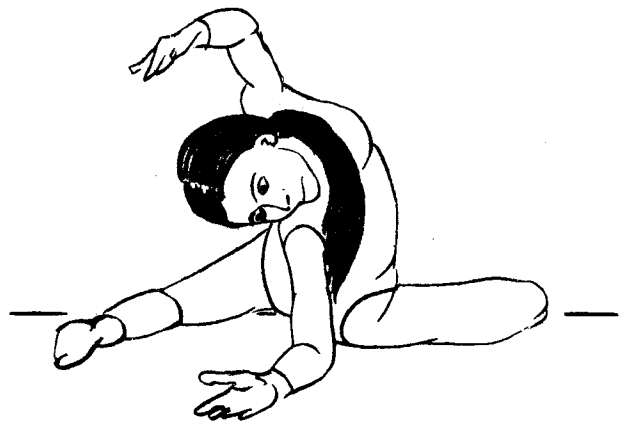
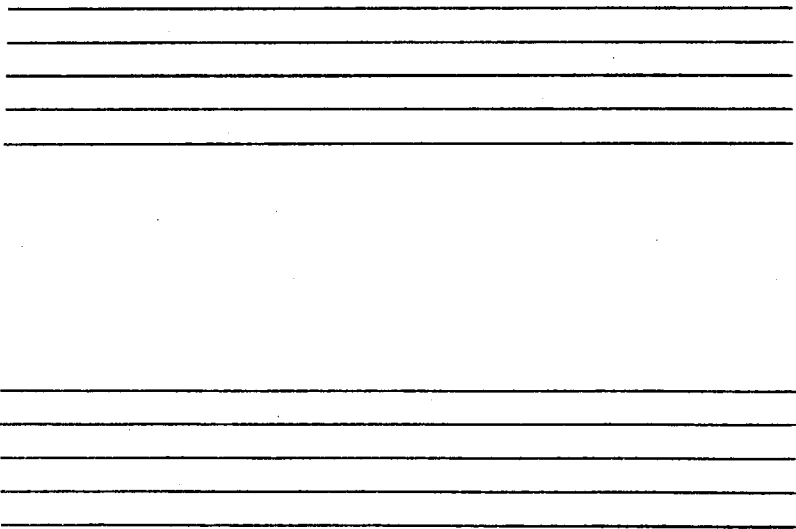
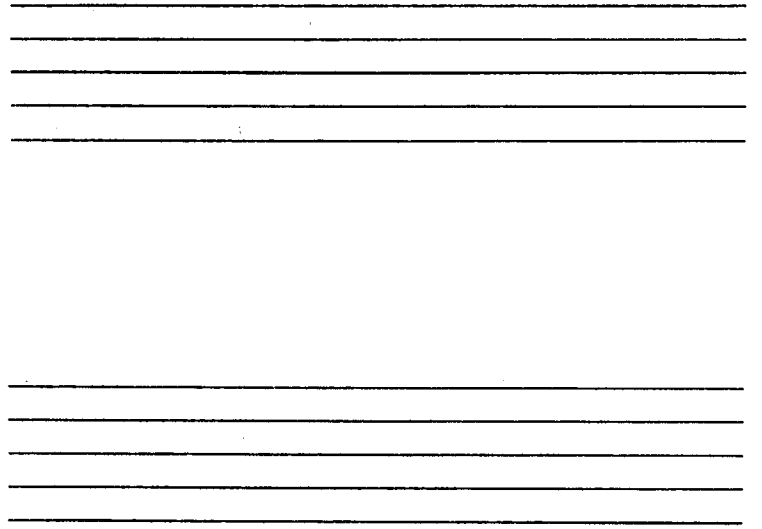

Copy each stick figure many times in a row for drawing practice:

I



II



III



IV

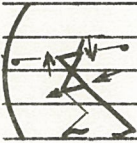

V

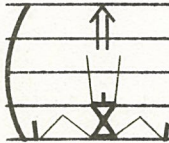

Notate the following figures facing all directions (including an In-Between Direction):

I



II

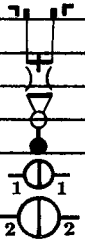

III

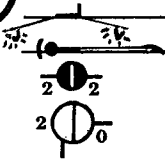

IV

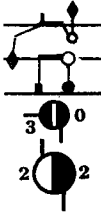

V





Notate the following modern dance and jazz dance steps:

1. Notate a spinal stretch and a spinal undulation

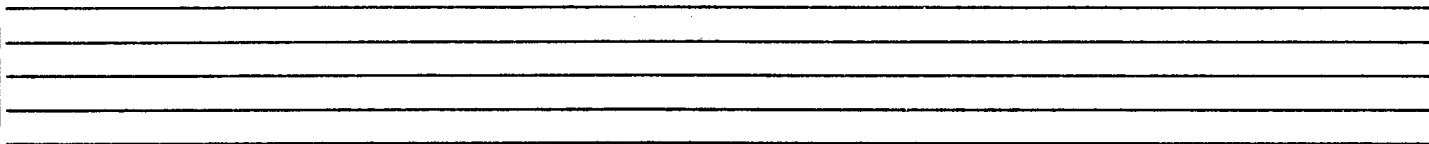

Four horizontal lines for handwriting, with a small square box on the left side.

2. Notate a Contraction - Release (Martha Graham)

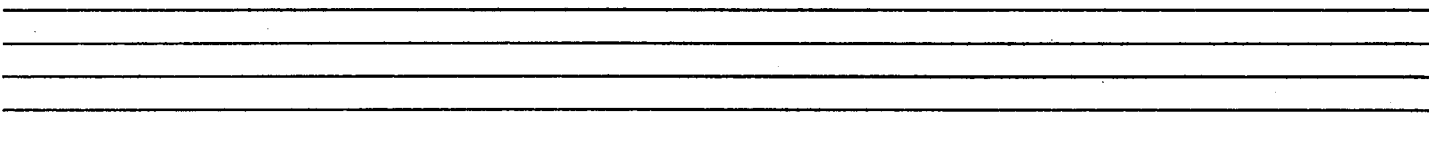

Four horizontal lines for handwriting, with a small square box on the left side.

3. Notate a Fall-Recovery Movement (Doris Humphrey)

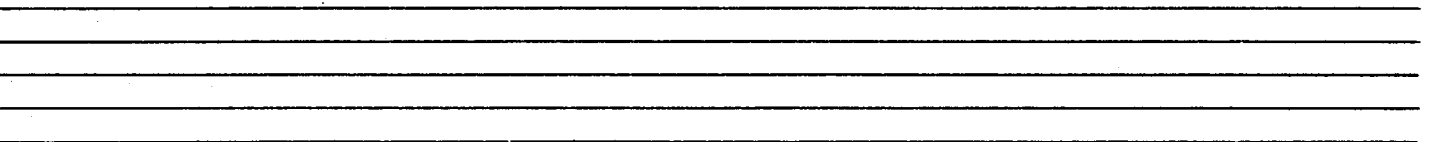

Four horizontal lines for handwriting, with a small square box on the left side.

4. Notate an isolation movement and/or a jazz walk

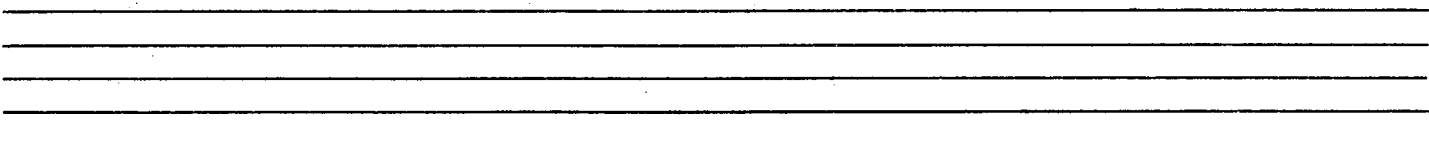

Four horizontal lines for handwriting, with a small square box on the left side.

Choreograph a movement sequence and notate it below, freehand.  
Try to incorporate many different kinds of movement found in  
modern dance and jazz dance styles.

A set of four horizontal lines for handwriting practice. A small square box is drawn on the left side, spanning the height of the second and third lines from the top.A set of four horizontal lines for handwriting practice. A small square box is drawn on the left side, spanning the height of the second and third lines from the top.A set of four horizontal lines for handwriting practice. A small square box is drawn on the left side, spanning the height of the second and third lines from the top.A set of four horizontal lines for handwriting practice. A small square box is drawn on the left side, spanning the height of the second and third lines from the top.A set of four horizontal lines for handwriting practice. A small square box is drawn on the left side, spanning the height of the second and third lines from the top.

## SUPPLEMENT TO QUICK WRITING BOOKLET

## MODERN AND JAZZ KEY

- Pg. 1 Heels are together; legs parallel; arms are relaxed to the sides of the body, relaxed hands.
- Pg. 2 Figure 1: Highest raise of the heels before full pointe.  
Figure 2: Intermediate raise of the heels.  
Figure 3: Slight raise of the heels.  
All arms are relaxed to the sides of the body, relaxed hands.
- Pg. 3 Figure 1: Full pointe, parallel.  
Figure 2: Large jump, parallel.  
All arms are relaxed , relaxed hands.
- Pg. 4 Top: Demi-plié; both arms are to the sides of the body, right wrist is flexed down, relaxed hands.  
Bottom: Full plié; arms straight to the side, heels raised; relaxed hands.
- Pg. 5 Top: Figure sits on its knees; arms are projecting straight in front of the body; palms face each other, flat hand.  
Bottom: Figure is kneeling; lower legs project straight to the back wall; arms are straight up; palms face each other, relaxed hands.
- Pg. 6 Top: Left upper leg projects to the floor, lower leg bent to the back wall; left arm projects straight in front of the body, palm to the floor, flat hand; right arm is straight

and up, relaxed hand.

Bottom: Figure faces the front wall; left leg is slightly turned-out; right leg is turned-in, bent at the knee, the thigh projects towards the back wall and the lower leg projects on the diagonal; hands are touching, relaxed, overhead and reach to the left side of the body; head is turned side and up.

Pg. 7 Top: left leg is bent at hip level to the front, pointed foot; relaxed hands.

Bottom: Figure on half toe, parallel, left leg is bent and turned-in, thigh projects down to the floor, lower leg projects to the back diagonal; the arms come straight down by the sides of the body and the forearms are bent to the front corner.

Pg. 8 Top: Figure faces the front, sitting on floor; right leg is bent in front of the body; left leg bent to the back corner; head looks to the side; relaxed hands.

Bottom: Figure sits on the floor with legs directly to the front of the body; arms directly to the back of the body just below the level of the shoulders; palms face each other, flat hands.

Pg. 9 Top: Figure is sitting on the floor in a split; right leg directly behind, left leg directly in front; both feet are pointed; arms bent to the front corners; hands are flat, palms face the body.

Bottom: Only the hips are on the floor, upper body is



slightly raised; legs are straight behind with pointed feet; arms are slightly curved to the side with a classical ballet hand, palm faces the audience.

Pg. 10 Top: Figure faces the audience and rests on its hands, figure on demi-pointe; legs are straight, both parallel; the left foot is pointed; head looks side.

Bottom: Figure faces the audience, right leg is slightly turned-out; left leg is straight to the side, foot flexed up; upper body is bent forwards; head is down; arms are curved the sides, relaxed hands.

Pg. 11 Top: left leg straight to the side turned-out, foot flexed up; relaxed hands.

Bottom: Figure is standing on its heels, legs turned out to the corners; hands are flexed up at the wrists.

Pg. 12 Top: Feet project on the sagittal plane, legs parallel, toes are flexed up. Arms project straight forward with flat hands, flexed up at the wrists.

Bottom: Left leg projects straight forward on the sagittal plane foot is flexed up; left arm to the side, hand flexed to the back wall, palm faces the side wall, flat hand; right arm relaxed to the side with relaxed hands.

Pg. 13 Figure 1: Feet parallel; wrists to the side of the body.

Figure 2: Feet parallel; arms to the side of the body

Figure 3: Right arm to the front of the body, left arm up to the side of the body; left ankle behind the body.



Note: palms should now be hollow triangles.

Figure 4: Right ankle to the front of the body, left ankle to the back of the body; right arm to the side of the body; left arm to the front diagonal.

Figure 5: Left ankle to the back diagonal of the body; shoulders twisted to face the front corner towards the rings; right arm is projecting to the back and left arm to the front on the sagittal plane of the room, palms facing down.

Pg. 14 Top Figure faces the front corner towards the tabs; figure is sitting on the floor and the feet are also touching the floor; arms rounded in front of the body, palms hold the ankles; back is straight.

Bottom: Same as figure above but the spine is rounded forward, head down.

Pg. 15 Top: Figure sits on the floor, facing front corner towards the tabs; both feet pointed straight in front of the body; left arm goes to the back wall; right arm projects to the back corner towards the rings with flexed wrist, relaxed hands.

Bottom: Figure faces the front corner towards the tabs in a tilt; top of left foot can be seen and is pointed; head looks to the right side; arms are straight to the sides of the body, relaxed hands.

Pg. 16 Top: Figure is sitting on the floor facing the front corner towards the rings; head is back; arms are rounded up to the sides of the body, palms to the ceiling, relaxed hands.

Bottom: Figure sitting on the floor facing the front corner towards the tabs; knees and feet are flexed up; head looks up and to the side; left arm is rounded up to the side of the body, palm to the ceiling; right arm is bent and crosses in front of the body, palm to the ceiling, classical ballet hands.

- Pg. 17 Top: Figure faces the front corner towards the tabs on demi-pointe; right leg is bent in front of the body, both legs are parallel, foot flexed up; head looks to the side; arms are straight to the sides of the body, palms facing the audience, fingers spread, flat hand.
- Bottom: Figure faces the front corner towards the rings in demi-point in demi-plié; left leg is pointed straight in front of the body; the torso contracts; left arm hangs down by the side of the body, palm to the body, relaxed hand, shoulder pressed forward; right arm bent in front of the body, palm to the floor, relaxed hand.

- Pg. 18 Top: Figure 1: Figure faces the front corner towards the tabs in parallel position, arms by the sides of the body, palms face the body.

Figure 2: Figure kneels facing the front corner towards the rings; right leg in front of the body; left leg is behind the body, foot pointed; right arm in front of the body, palm down; left arm to the side of the body, palm down.

Note: Palms should be hollow triangles.

Figure 3: Figure faces the front corner towards the tabs; both legs are in front of the body; right arm projects on



the sagittal plane of the room, palm down; left arm is bent up to the side of the body, palm facing the top of the head.

Figure 4: Faces the front corner towards the rings; both arms are straight in front of the body, palms facing each other.

Figure 5: Faces the front corner towards the tabs; both legs are behind the body the left knee is on the floor; arms are bent to the sides of the body, palms touching the floor.

Pg. 19 Top: Figure faces the side towards the rings in a parallel position; torso is contracted; head looks up; arms are high to the front of the body, wrists are flexed with right angle hands, palms facing the side wall. (Hand is the Martha Graham style).

Bottom: Figure faces the side towards the tabs; knees project on the sagittal plane of the room; arms are rounded in front of the body, palms hold the ankles; back straight

Pg. 20 Top: Lower body kneels facing the side towards the tabs while the upper body twists to face the front corner towards the tabs; head is up; right leg is closer to the audience, left leg is in front of the right; right arm rounded to the side of the body, classical ballet hand, palm faces the body; left arm rounded in front of the body, classical ballet hand, palm faces the body; right foot is pointed.

Bottom: Figure kneels facing side towards the rings; left foot is pointed; torso tilts forward; head center and down; right arm low to the back of the body, thumb faces the



legs together in front of the body, right over left; knees to chest, parallel; arms crossed in front, palms to chest.

Pg. 23 Figure 1: Feet flat, parallel, heels on ground.

Figure 2: Heels raised slightly off ground.

Figure 3 Highest raise of heels possible before full pointe.

All legs are parallel; arms relaxed to the sides of the body, palms facing the body, relaxed hands.

Pg. 24 Figure 1: Full pointe.

Figure 2: Large jump.

All arms relaxed with relaxed hands.

Pg. 25 Top: Demi-plié, parallel; both arms are to the sides of the body, palms facing the body.

Bottom: Figure sits on its heels; arms to the side of the body, palms facing the body, hands relaxed; knees touch the ground.

Pg. 26 Top: Figure sits on pointed feet; arms are rounded to the sides of the body, palms face the body.

Bottom: Both arms and legs project straight to the back wall at the level of the shoulders and hips respectively; palms face the floor; legs parallel.

Pg. 27 Top: Figure faces the back wall; left leg bent, knee to back wall, foot to the back corner; right ankle crosses behind left leg on the diagonal partially turned-out; both arms are far to the left side of the body, wrists flexed, palms to the floor, relaxed hands; hips and shoulders tilted.



Bottom: Figure faces the back wall; both legs are turned-out sole of the left foot can be seen; left arm is close to the body, flexed at wrist, palm on the floor; right arm to the side of the body, palm to the floor; hips tilted, relaxed hands.

- Pg. 28 Top: Figure faces the back wall; both legs turned-out, right leg is in front of the body, left leg is in back of the body; both arms are far to the sides of the body, open palms face the back wall, fingers stretched.
- Bottom: Lower body faces the back corner towards the tabs while the upper body twists and bends to face the side wall; right leg in front of the body, left pointed behind, sole of foot can be seen; right arm bent far to the back corner of the body, back of hand rests on the floor; left arm bent close and to the back of the head.
- Pg. 29 Figure 1: Parallel position; arms to the sides of the body, palms face the body.
- Figure 2: parallel plié; palms face the floor.
- Figure 3: Both legs partially turned-in; right leg on demi-pointe projecting to the front corner towards the tabs; arms far to the sides of the body, palms to the floor.
- Note: Hollow half ovals should replace dark half ovals.
- Figure 5: Legs turned-out to the sides of the body; arms above the head to the sides of the body, palms facing each other.
- Pg. 30 Figure 3: Note; Hollow triangles should replace dark triangles.





The Pictorial Handwriting for Writing The Movements of All Dance Forms



# Dance Writing<sup>T.M.</sup>



FOR  
MODERN AND JAZZ DANCE

Valerie Sutton